



Avon Town Council Meeting March 12th, 2026 at 7:00 PM  
at Avon Town Hall

**1. Start Of Meeting**

- o Call to Order
- o Pledge of Allegiance
- o Roll Call
- o Determination of Quorum

**2. Swearing In Police Officers**

**3. Consent Agenda**

**3.1. Check Register March 12, 2026**

*Documents:*

[CHK 3.12.26.PDF](#)

**3.2. Approval Of Minutes- February 26th, 2026**

[HTTPS://WWW.AVONINDIANA.GOV/AGENDACENTER/VIEWFILE/MINUTES/\\_02262026-498](https://www.avonindiana.gov/agendacenter/viewfile/minutes/_02262026-498)

**4. Public Comment**

The public may comment on items on the agenda that are not a public hearing or on a specific matter within the Council's jurisdiction.

**5. Department Updates**

**6. Council Comment And Liaison Reports**

**7. New Business**

**7.1. Award Bid For Park Improvements**

*Documents:*

[A PROPOSED BURNETT IMPROVEMENTS.PDF](#)  
[B WINTON MEADOWS IMPROVEMENT.PDF](#)  
[C BURNETT AND WINTON MEADOWS BIDS.PDF](#)  
[D BID ALTERNATES.PDF](#)  
[E RECOMMENDATION.PDF](#)

F SOURCES.PDF  
G USES.PDF  
H AVAILABLE FUNDS.PDF

## 7.2. Award Bid For Pickleball Park

*Documents:*

A AVON PICKLEBALL PARK.PDF  
B PICKLEBALL BID RESULTS.PDF  
C RECOMMENDATION.PDF  
D SOURCES.PDF  
E USES.PDF  
F AVAILABLE FUNDS.PDF

## 7.3. Professional Services Agreement Rigdon Construction C'Ma

*Documents:*

RIGDON - TOWN OF AVON - CMA SERVICES 2026-03-06.PDF

## 7.4. Award Quote For Roadside Mowing

*Documents:*

A RECOMMENDATION TO COUNCIL ROW CONTRACT.PDF  
B 2026 BUDGET ROADSIDE MOWING.PDF  
C AVAILABLE FUNDS.PDF

## 7.5. Award Quote For Roundabout Maintenance

*Documents:*

A RECOMMENDATION TO COUNCIL RAB CONTRACT.PDF  
B 2026 BUDGET RDBT MAINT.PDF  
C AVAILABLE FUNDS.PDF

## 7.6. Award Quote For ADA Sidewalk Replacements And New Construction

*Documents:*

A RECO TO COUNCIL-HARVEST LANDING-SIDEWALKS-DRAINAGE.PDF  
B 2026 PW BUDGET - ADA SIDEWALKS.PDF  
C AVAILABLE FUNDS.PDF

## 7.7. IWorQ Agreement Amendment

*Documents:*

A AVON, IN PLANNING AND ZONING.PDF  
B AVON, IN CURRENT CONTRACT.PDF  
C 2026 BUDGET.PDF  
D AVAILABLE FUNDS.PDF

## 8. MakeMyMove Proposal

*Documents:*

[A TOWN OF AVON PROPOSAL 1.6.25.PDF](#)  
[B AVON PROGRESS REPORT Q1\\_2026.PDF](#)  
[C TOWN OF AVON, IN CONTRACT \(5 MOVERS\) 3.6.26.PDF](#)  
[D AVAILABLE FUNDS.PDF](#)

**9. Resolution**

**9.1. Resolution 2026-09: Purchase Agreement For Police Substation And Training**

*Documents:*

[2026-09 APPROVING PURCHASE AGREEMENT \(AVON MAP LLC\).PDF](#)  
[2026-09 EXHIBIT A PURCHASE AGREEMENT.PDF](#)  
[HRH POLICE STATION CASH FLOW 03 06 26 TP.PDF](#)

**10. Resolution 2026-10: Naming Town Parks And Trails**

*Documents:*

[2026-10 NAMING PARKS AND TRAILS.PDF](#)

**11. Ordinance**

**11.1. Final Reading Ordinance 2026-04: Prohibiting Obstruction Of Mailboxes**

*Documents:*

[2026-04 PROHIBITING OBSTRUCTION OF MAILBOX \(FINAL\).PDF](#)

**11.2. Final Reading Ordinance 2026-05: Buy Money Program And Fund**

*Documents:*

[2026-05 BUY MONEY PROGRAM AND FUND \(FINAL\).PDF](#)

**11.3. Final Reading Ordinance 2026-06: ZA 25-03 The Gatherings**

*Documents:*

[2026-06 REZONING FOR ZA 25-03 THE GATHERINGS.PDF](#)  
[2026-06 -PLAN COMMISSION CERTIFICATE ZA 25-03.PDF](#)

**12. Legal Counsel Report**

**13. Public Comment**

The public may comment on items on the agenda that are not a public hearing or on a specific matter within the Council's jurisdiction.

**14. Council Comment**

**15. Council Calendar**

**16. Adjournment**

Anyone who requires an auxiliary aid or service for effective communication, or a modification of policies or procedures to participate in a program, service, or activity of Town of Avon, should contact the Town Administrative Offices as soon as possible but no later than 48 hours before the

scheduled event.

*"Avon is a safe, vibrant community for active families and thriving businesses."*  
Avon Town Hall | 6570 East US Highway 36 | Avon, IN 46123 | 317-272-0948 | avonindiana.gov |  
Next Meeting: 03/26/2026

*These minutes are meant to be a summary of actions taken at the Avon Town Council Meeting.  
Please refer to the following address to view this meeting in its entirety.  
<https://avonindiana.gov/AgendaCenter>*

<b>Member</b>	<b>Elected by</b>	<b>Term Exp</b>
Greg Zusan	Ward 1	1/2023 - 12/2026
Dawn Lowden	Ward 2	1/2023 - 12/2026
Bill Holland	Ward 3	1/2023 - 12/2026
Jayson Puckett	At-Large	1/2024 - 12/2027
Robert Pope	At-Large	1/2024 - 12/2027

Check Register

Vendor Status Chk-Acct	Vendor Name Transaction-Description Account-Number	Invoice-No	Trans-mmyy PO-Number Liq Account-Description	Due Date PO-Date	Invoice-Date Check-Date	Invoice-Total Amount	Claim-Number Check-Number Action	Remit-Addr
2717 Released	1816 PUBLIC AFFAIRS GROUP, LLC SERVICE AGREEMENT 2026	5265	03/2026	03/12/2026	03/01/2026 03/12/2026	8,000.00	36103 1	
01	1101.101.431.104		OTHER PROFESSIONAL SERVICES			8,000.00	Expense	
*** Check-Number= 36103 Vendor Name= 1816 PUBLIC AFFAIRS GROUP, LLC Check Date= 03/12/2026						Check Amount=	8,000.00	***
2489 Released	ACE K9* ACE WATCHDOG SERVICE (5)	298767	03/2026	03/12/2026	03/04/2026 03/12/2026	840.00	36104 1	
01	1101.201.422.104		K-9 SUPPLIES			840.00	Expense	
*** Check-Number= 36104 Vendor Name= ACE K9* Check Date= 03/12/2026						Check Amount=	840.00	***
1083 Released	ALL TERRAIN LANDSCAPE* AVON BALLFIELDS 104	409547	03/2026	03/12/2026	03/01/2026 03/12/2026	1,549.20	36105 1	
01	2211.501.431.116		MISC CONTRACTUAL			1,549.20	Expense	
1083 Released	ALL TERRAIN LANDSCAPE* AVON BALLFIELDS 866	409550	03/2026	03/12/2026	03/01/2026 03/12/2026	1,371.99	36105 1	
01	2211.501.431.116		MISC CONTRACTUAL			1,371.99	Expense	
1083 Released	ALL TERRAIN LANDSCAPE* LIQUID SALT	409487	03/2026	03/12/2026	02/25/2026 03/12/2026	250.00	36105 1	
01	2201.301.431.109		MVH CONTRACTUAL SERVICE			250.00	Expense	
1083 Released	ALL TERRAIN LANDSCAPE* LIQUID SALT	409461	03/2026	03/12/2026	02/25/2026 03/12/2026	1,174.80	36105 1	
01	2201.301.431.109		MVH CONTRACTUAL SERVICE			1,174.80	Expense	
*** Check-Number= 36105 Vendor Name= ALL TERRAIN LANDSCAPE* Check Date= 03/12/2026						Check Amount=	4,345.99	***
2207 Released	AMAZON CAPITAL SERVICES* LEATHER DESK PAD	19R7-VWXQ-4NL1	03/2026	03/12/2026	02/16/2026 03/12/2026	13.29	36106 1	
01	1101.104.444.105		COMPUTER EQUIPMENT			13.29	Expense	
2207 Released	AMAZON CAPITAL SERVICES* ART CANVAS	1YJW-4G6D-4FPD	03/2026	03/12/2026	02/23/2026 03/12/2026	46.77	36106 1	
01	1101.104.444.105		COMPUTER EQUIPMENT			46.77	Expense	
2207 Released	AMAZON CAPITAL SERVICES* SUPPLIES	1VJK-NL7H-Y4K6	03/2026	03/12/2026	02/21/2026 03/12/2026	498.08	36106 1	
01	1101.201.422.101		LAW ENFORCEMENT SUPPLIES			498.08	Expense	
01	1101.201.422.101		LAW ENFORCEMENT SUPPLIES			498.08	Liquidation	
2207 Released	AMAZON CAPITAL SERVICES* SUPPLIES	1CNN-NL7H-1HF7	03/2026	03/12/2026	02/20/2026 03/12/2026	52.14	36106 1	
01	1101.201.422.101		LAW ENFORCEMENT SUPPLIES			52.14	Expense	
01	1101.201.422.101		LAW ENFORCEMENT SUPPLIES			52.14	Liquidation	

Check Register

Vendor Status Chk-Acct	Vendor Name Transaction-Description Account-Number	Invoice-No PO-Number Account-Description	Trans-mmyy Liq	Due Date PO-Date	Invoice-Date Check-Date	Invoice-Total Amount	Claim-Number Check-Number	Remit-Addr
2207 Released	AMAZON CAPITAL SERVICES* SUPPLIES	1L1F-QHVL-TJMQ	03/2026 P	03/12/2026 01/15/2026	02/19/2026 03/12/2026	23.69	36106	1
01	1101.201.422.101	LAW ENFORCEMENT SUPPLIES				23.69	Expense	
01	1101.201.422.101	LAW ENFORCEMENT SUPPLIES				23.69	Liquidation	
2207 Released	AMAZON CAPITAL SERVICES* SUPPLIES	1Q9K-F943-W1DX	03/2026 P	03/12/2026 01/15/2026	02/18/2026 03/12/2026	41.78	36106	1
01	1101.201.422.101	LAW ENFORCEMENT SUPPLIES				41.78	Expense	
01	1101.201.422.101	LAW ENFORCEMENT SUPPLIES				41.78	Liquidation	
2207 Released	AMAZON CAPITAL SERVICES* SUPPLIES	1XYT-YCN6-QRFV	03/2026 P	03/12/2026 01/15/2026	02/18/2026 03/12/2026	131.33	36106	1
01	1101.201.422.101	LAW ENFORCEMENT SUPPLIES				131.33	Expense	
01	1101.201.422.101	LAW ENFORCEMENT SUPPLIES				131.33	Liquidation	
2207 Released	AMAZON CAPITAL SERVICES* SUPPLIES	13WK-RY1F-VMV	03/2026 P	03/12/2026 01/15/2026	02/18/2026 03/12/2026	19.88	36106	1
01	1101.201.422.101	LAW ENFORCEMENT SUPPLIES				19.88	Expense	
01	1101.201.422.101	LAW ENFORCEMENT SUPPLIES				19.88	Liquidation	
2207 Released	AMAZON CAPITAL SERVICES* SUPPLIES	1T7F-N1R1-VRWJ	03/2026 P	03/12/2026 01/15/2026	02/18/2026 03/12/2026	32.93	36106	1
01	1101.201.422.101	LAW ENFORCEMENT SUPPLIES				32.93	Expense	
01	1101.201.422.101	LAW ENFORCEMENT SUPPLIES				32.93	Liquidation	
2207 Released	AMAZON CAPITAL SERVICES* SUPPLIES	1RFY-1M1K-V3NK	03/2026 P	03/12/2026 01/15/2026	02/18/2026 03/12/2026	30.52	36106	1
01	1101.201.422.101	LAW ENFORCEMENT SUPPLIES				30.52	Expense	
01	1101.201.422.101	LAW ENFORCEMENT SUPPLIES				30.52	Liquidation	
2207 Released	AMAZON CAPITAL SERVICES* SUPPLIES	1JDW-M9C1-71W3	03/2026 P	03/12/2026 01/15/2026	02/24/2026 03/12/2026	72.57	36106	1
01	1101.201.422.101	LAW ENFORCEMENT SUPPLIES				72.57	Expense	
01	1101.201.422.101	LAW ENFORCEMENT SUPPLIES				72.57	Liquidation	
2207 Released	AMAZON CAPITAL SERVICES* SUPPLIES	1PJX-WMXF-7D7Y	03/2026 P	03/12/2026 01/15/2026	02/24/2026 03/12/2026	9.49	36106	1
01	1101.201.422.101	LAW ENFORCEMENT SUPPLIES				9.49	Expense	
01	1101.201.422.101	LAW ENFORCEMENT SUPPLIES				9.49	Liquidation	
2207 Released	AMAZON CAPITAL SERVICES* SUPPLIES	1YQL-PF67-DJPK	03/2026 P	03/12/2026 01/15/2026	02/24/2026 03/12/2026	142.47	36106	1
01	1101.201.422.101	LAW ENFORCEMENT SUPPLIES				142.47	Expense	
01	1101.201.422.101	LAW ENFORCEMENT SUPPLIES				142.47	Liquidation	
2207 Released	AMAZON CAPITAL SERVICES* SUPPLIES	1TVV-1YQ6-CFPX	03/2026 P	03/12/2026 01/15/2026	02/25/2026 03/12/2026	25.16	36106	1
01	1101.201.422.101	LAW ENFORCEMENT SUPPLIES				25.16	Expense	
01	1101.201.422.101	LAW ENFORCEMENT SUPPLIES				25.16	Liquidation	

\*\*\* Check-Number= 36106 Vendor Name= AMAZON CAPITAL SERVICES\* Check Date= 03/12/2026 Check Amount= 1,140.10 \*\*\*

Check Register

Vendor Status Chk-Acct	Vendor Name Transaction-Description Account-Number	Invoice-No	Trans-mmyy PO-Number Liq PO-Date	Due Date PO-Date	Invoice-Date Check-Date	Invoice-Total Amount	Claim-Number Check-Number	Remit-Addr
2207 Released	AMAZON CAPITAL SERVICES* PICNIC EVENT	1PRQ-L4X7-36D3	03/2026	03/12/2026	02/23/2026 03/12/2026	39.83	36107	1
01	4439.501.431.105	PROGRAMS & ACTIVITES				39.83	Expense	
2207 Released	AMAZON CAPITAL SERVICES* ADMIN SUPPLIES	1JT6-9QMJ-1C9F	03/2026	03/12/2026	02/23/2026 03/12/2026	60.58	36107	1
01	1101.103.421.103	MISC SUPPLIES				60.58	Expense	
2207 Released	AMAZON CAPITAL SERVICES* ADMIN SUPPLIES	1RW3-34VG-JCJ4	03/2026	03/12/2026	03/02/2026 03/12/2026	158.97	36107	1
01	1101.103.421.103	MISC SUPPLIES				158.97	Expense	
*** Check-Number= 36107 Vendor Name= AMAZON CAPITAL SERVICES* Check Date= 03/12/2026						Check Amount=	259.38 ***	
2275 Released	AUTO LAB* OIL CHANGE	65198	03/2026	03/12/2026	02/24/2026 03/12/2026	69.93	36108	1
01	1101.201.436.101	REPAIR AND MAINTENANCE				69.93	Expense	
2275 Released	AUTO LAB* OIL CHANGE	65175	03/2026	03/12/2026	02/19/2026 03/12/2026	69.83	36108	1
01	1101.201.436.101	REPAIR AND MAINTENANCE				69.83	Expense	
2275 Released	AUTO LAB* OIL CHANGE	65166	03/2026	03/12/2026	02/18/2026 03/12/2026	69.29	36108	1
01	1101.201.436.101	REPAIR AND MAINTENANCE				69.29	Expense	
*** Check-Number= 36108 Vendor Name= AUTO LAB* Check Date= 03/12/2026						Check Amount=	209.05 ***	
1412 Released	AUTOZONE, INC.* MOTOR OIL	03582743129	03/2026	03/12/2026	02/23/2026 03/12/2026	18.60	36109	1
01	1101.201.436.101	REPAIR AND MAINTENANCE				18.60	Expense	
*** Check-Number= 36109 Vendor Name= AUTOZONE, INC.* Check Date= 03/12/2026						Check Amount=	18.60 ***	
394 Released	AVON COMMUNITY SCHOOL CORPORAT VEHICLE FUEL FOR FEBRUARY	PD03032026	03/2026	03/12/2026	03/03/2026 03/12/2026	10,810.72	36110	1
01	1101.201.435.102	VEHICLE FUEL				10,810.72	Expense	
394 Released	AVON COMMUNITY SCHOOL CORPORAT VEHICLE FUEL FOR FEBRUARY	TOFA03032026	03/2026	03/12/2026	03/03/2026 03/12/2026	948.53	36110	1
01	1101.301.435.102	UTITLITY-VEHICLE FUEL				948.53	Expense	
*** Check-Number= 36110 Vendor Name= AVON COMMUNITY SCHOOL CORPORAT Check Date= 03/12/2026						Check Amount=	11,759.25 ***	
930 Released	AXON ENTERPRISE, INC* TASET 90 HOLSTER (1)	INUS424397	03/2026	03/12/2026	02/20/2026 03/12/2026	88.58	36111	1
01	1101.201.422.101	LAW ENFORCEMENT SUPPLIES				88.58	Expense	
*** Check-Number= 36111 Vendor Name= AXON ENTERPRISE, INC* Check Date= 03/12/2026						Check Amount=	88.58 ***	

Check Register

A20260

JL

03/05/2026 17:21:37

Vendor Status Chk-Acct	Vendor Name Transaction-Description Account-Number	Invoice-No	Trans-mnyy PO-Number	Due Date Liq PO-Date	Invoice-Date Check-Date	Invoice-Total Amount	Claim-Number Check-Number	Remit-Addr
1998 Released	B & S BOARDING AND GROOMING* KENNEL	APD01_2026	03/2026 2025-012	03/12/2026 P 01/15/2026	03/02/2026 03/12/2026	567.00	36112	1
01	1101.201.422.104			K-9 SUPPLIES		567.00	Expense	
01	1101.201.422.104			K-9 SUPPLIES		567.00	Liquidation	
*** Check-Number= 36112 Vendor Name= B & S BOARDING AND GROOMING* Check Date= 03/12/2026 Check Amount= 567.00 ***								
901 Released	BANNING ENGINEERING, P.C* TRAIL DESIGN AJAA	2510175	03/2026 2022-06	03/12/2026 P 01/18/2023	10/13/2025 03/12/2026	2,160.00	36113	1
01	4439.501.431.115			MISC CONSULTING		2,160.00	Expense	
01	4439.501.431.115			MISC CONSULTING		2,160.00	Liquidation	
*** Check-Number= 36113 Vendor Name= BANNING ENGINEERING, P.C* Check Date= 03/12/2026 Check Amount= 2,160.00 ***								
2003 Released	BEST ONE INDY* TIRES (2)	1120052247	03/2026	03/12/2026	02/20/2026 03/12/2026	303.78	36114	1
01	1101.201.436.101			REPAIR AND MAINTENANCE		303.78	Expense	
2003 Released	BEST ONE INDY* TIRES (4)	1120052419	03/2026	03/12/2026	02/26/2026 03/12/2026	784.52	36114	1
01	1101.201.436.101			REPAIR AND MAINTENANCE		784.52	Expense	
2003 Released	BEST ONE INDY* OIL CHANGE	1120052519	03/2026	03/12/2026	02/27/2026 03/12/2026	75.98	36114	1
01	4439.501.422.102			REPAIR & MAINTENANCE SUPPLIES		75.98	Expense	
2003 Released	BEST ONE INDY* OIL CHANGE & LIGHT BULB REPLACED	1120052244	03/2026	03/12/2026	02/18/2026 03/12/2026	102.98	36114	1
01	4439.501.422.102			REPAIR & MAINTENANCE SUPPLIES		102.98	Expense	
*** Check-Number= 36114 Vendor Name= BEST ONE INDY* Check Date= 03/12/2026 Check Amount= 1,267.26 ***								
9 Released	BOYCE FORMS/SYSTEMS* RECEIPT BOOKS FOR CT	125759	03/2026	03/12/2026	02/27/2026 03/12/2026	614.80	36115	1
01	1101.102.421.103			MISC SUPPLIES		614.80	Expense	
*** Check-Number= 36115 Vendor Name= BOYCE FORMS/SYSTEMS* Check Date= 03/12/2026 Check Amount= 614.80 ***								
1815 Released	BROOKFIELD SAND & GRAVEL, INC. S95293 FILL SAND		03/2026	03/12/2026	01/28/2026 03/12/2026	5,089.00	36116	1
01	2201.301.431.109			MVH CONTRACTUAL SERVICE		5,089.00	Expense	
*** Check-Number= 36116 Vendor Name= BROOKFIELD SAND & GRAVEL, INC. Check Date= 03/12/2026 Check Amount= 5,089.00 ***								
1647 Released	CHA* BRIDGE	82869-002	03/2026 2025-017	03/12/2026 P 01/15/2026	02/16/2026 03/12/2026	3,416.58	36117	1
01	4443.501.411.103			OTHER PROFESSIONAL SERVICES		3,416.58	Expense	
01	4443.501.411.103			OTHER PROFESSIONAL SERVICES		3,416.58	Liquidation	
*** Check-Number= 36117 Vendor Name= CHA* Check Date= 03/12/2026 Check Amount= 3,416.58 ***								

Check Register

A20260

JL

03/05/2026 17:21:37

Vendor Status Chk-Acct	Vendor Name Transaction-Description Account-Number	Invoice-No	Trans-mmyy PO-Number Liq PO-Date	Due Date PO-Date	Invoice-Date Check-Date	Invoice-Total Amount	Claim-Number Check-Number	Remit-Addr
1980 Released	CHICAGO TITLE COMPANY, LLC* TITLE SEARCH-PICKLEBALL COURT LAND	CTIN2600498	03/2026	03/12/2026	02/10/2026 03/12/2026	300.00	36118	1
01	4439.501.431.104		PROFESSIONAL SERVICES			300.00	Expense	
*** Check-Number= 36118 Vendor Name= CHICAGO TITLE COMPANY, LLC* Check Date= 03/12/2026 Check Amount= 300.00 ***								
2027 Released	COPPERHEAD RIDGE FIREARMS* 24 SOL LOWERS	1614	03/2026	03/12/2026	02/19/2026 2025-006 E 01/15/2026	6,935.00	36119	1
01	1101.201.422.101		LAW ENFORCEMENT SUPPLIES			6,000.00	Expense	
01	1101.201.422.101		LAW ENFORCEMENT SUPPLIES			935.00	Expense	
01	1101.201.422.101		LAW ENFORCEMENT SUPPLIES			6,000.00	Liquidation	
*** Check-Number= 36119 Vendor Name= COPPERHEAD RIDGE FIREARMS* Check Date= 03/12/2026 Check Amount= 6,935.00 ***								
2484 Released	CORVUS JANITORIAL OF INDIANAPO JANITORIAL SERVICES	603347003-0315	03/2026	03/12/2026	03/01/2026 03/12/2026	330.75	36120	1
01	2211.501.431.116		MISC CONTRACTUAL			330.75	Expense	
*** Check-Number= 36120 Vendor Name= CORVUS JANITORIAL OF INDIANAPO Check Date= 03/12/2026 Check Amount= 330.75 ***								
2764 Released	D & D AUTO AND TOWING, LLC * OXYGEN SENSOR	19441	03/2026	03/12/2026	03/03/2026 03/12/2026	284.04	36121	1
01	1101.201.436.101		REPAIR AND MAINTENANCE			284.04	Expense	
2764 Released	D & D AUTO AND TOWING, LLC * DIFFERENTIAL, BATTERY	19297	03/2026	03/12/2026	03/03/2026 03/12/2026	2,249.49	36121	1
01	1101.201.436.101		REPAIR AND MAINTENANCE			2,249.49	Expense	
2764 Released	D & D AUTO AND TOWING, LLC * VEHICLE REPAIRS	19097-2	03/2026	03/12/2026	02/02/2026 03/12/2026	170.08	36121	1
01	1101.201.436.101		REPAIR AND MAINTENANCE			170.08	Expense	
*** Check-Number= 36121 Vendor Name= D & D AUTO AND TOWING, LLC * Check Date= 03/12/2026 Check Amount= 2,703.61 ***								
2544 Released	DESTINATION ATHLETE OF INDIANA SOFTBALLS	1647	03/2026	03/12/2026	03/04/2026 03/12/2026	2,423.35	36122	1
01	2211.501.422.101		OPERATING SUPPLIES			2,423.35	Expense	
*** Check-Number= 36122 Vendor Name= DESTINATION ATHLETE OF INDIANA Check Date= 03/12/2026 Check Amount= 2,423.35 ***								
2347 Released	DONE AND DUSTED, LLC* MARCH JANITORIAL	1390	03/2026	03/12/2026	02/23/2026 03/12/2026	1,462.50	36123	1
01	1101.201.431.109		OTHER PROFESSIONAL SERVICE			1,462.50	Expense	
*** Check-Number= 36123 Vendor Name= DONE AND DUSTED, LLC* Check Date= 03/12/2026 Check Amount= 1,462.50 ***								
2635 Released	EDGE-WORKS MANUFACTURING* HOLSTER ADAPTOR FOR TASERS (9)	1336183	03/2026	03/12/2026	02/20/2026 03/12/2026	323.82	36124	1
01	1101.201.422.101		LAW ENFORCEMENT SUPPLIES			323.82	Expense	
*** Check-Number= 36124 Vendor Name= EDGE-WORKS MANUFACTURING* Check Date= 03/12/2026 Check Amount= 323.82 ***								

Check Register

Vendor Status Chk-Acct	Vendor Name Transaction-Description Account-Number	Invoice-No	Trans-mmyy PO-Number Liq	Due Date PO-Date	Invoice-Date Check-Date	Invoice-Total Amount	Claim-Number Check-Number	Remit-Addr
599 Released	EDWARDS EQUIPMENT COMPANY* BACKPACK BLOWER PRO	01-18199	03/2026	03/12/2026	02/27/2026 03/12/2026	499.99	36125	1
01	2211.501.421.105		OFFICE SUPPLIES			499.99	Expense	
*** Check-Number= 36125 Vendor Name= EDWARDS EQUIPMENT COMPANY* Check Date= 03/12/2026 Check Amount= 499.99 ***								
2395 Released	ENDEAVOR COMMUNICATIONS* UTILITIES	03012026	03/2026	03/12/2026	03/01/2026 03/12/2026	269.99	36126	1
01	1101.103.432.105		TELEPHONE			269.99	Expense	
*** Check-Number= 36126 Vendor Name= ENDEAVOR COMMUNICATIONS* Check Date= 03/12/2026 Check Amount= 269.99 ***								
810 Released	ERMCO, INC* CONTROL BOX REPAIR	910026899	03/2026	03/12/2026	02/23/2026 03/12/2026	250.00	36127	1
01	2201.301.435.101		REPAIRS & MAINTENANCE			250.00	Expense	
*** Check-Number= 36127 Vendor Name= ERMCO, INC* Check Date= 03/12/2026 Check Amount= 250.00 ***								
2945 Released	FIDES COMMUNICATION* OFFICE PHONE/INTERNET	071511	03/2026	03/12/2026	02/12/2026 03/12/2026	74.99	36128	1
01	2211.501.435.101		PARK REC UTILITES			74.99	Expense	
*** Check-Number= 36128 Vendor Name= FIDES COMMUNICATION* Check Date= 03/12/2026 Check Amount= 74.99 ***								
7 Released	FINLEY* LAURA REIMBURSEMENT FOR JEANS	02222026	03/2026	03/12/2026	02/22/2026 03/12/2026	54.00	36129	1
01	1101.104.413.107		CLOTHING ALLOWANCE			54.00	Expense	
*** Check-Number= 36129 Vendor Name= FINLEY* LAURA Check Date= 03/12/2026 Check Amount= 54.00 ***								
189 Released	FOX CONTRACTORS CORP* SNOW EVENTS	61517	03/2026	03/12/2026	02/20/2026 03/12/2026	145,883.51	36130	1
01	2201.301.431.109		MVH CONTRACTUAL SERVICE			145,883.51	Expense	
189 Released	FOX CONTRACTORS CORP* SNOW REMOVAL	61534	03/2026	03/12/2026	02/23/2026 03/12/2026	11,365.00	36130	1
01	2201.301.431.109		MVH CONTRACTUAL SERVICE			11,365.00	Expense	
*** Check-Number= 36130 Vendor Name= FOX CONTRACTORS CORP* Check Date= 03/12/2026 Check Amount= 157,248.51 ***								
2943 Released	FRONT LINE COUNSELING INC.* COUNSELING	02182026	03/2026	03/12/2026	02/18/2026 03/12/2026	4,970.00	36131	1
01	1101.201.431.109		OTHER PROFESSIONAL SERVICE			4,970.00	Expense	
*** Check-Number= 36131 Vendor Name= FRONT LINE COUNSELING INC.* Check Date= 03/12/2026 Check Amount= 4,970.00 ***								
2694 Released	GINO GINO, ANGEL* GYM REIMBURSEMENT	03042026	03/2026	03/12/2026	03/04/2026 03/12/2026	30.00	36132	1
01	1101.103.413.115		OTHER EMPLOYEE BENEFIT			30.00	Expense	
*** Check-Number= 36132 Vendor Name= GINO GINO, ANGEL* Check Date= 03/12/2026 Check Amount= 30.00 ***								

Check Register

Vendor Status Chk-Acct	Vendor Name Transaction-Description Account-Number	Invoice-No	Trans-mnyy PO-Number	Due Date Liq PO-Date	Invoice-Date Check-Date	Invoice-Total Amount	Claim-Number Check-Number	Remit-Addr
2946 Released	GRAND PARK FIELDHOUSE, LLC* PROGRAMMING REGISTRATIONS	INV99978	03/2026	03/12/2026	01/07/2026 03/12/2026	3,200.00	36133	1
01	2211.501.422.101		OPERATING SUPPLIES			3,200.00	Expense	
*** Check-Number= 36133 Vendor Name= GRAND PARK FIELDHOUSE, LLC* Check Date= 03/12/2026 Check Amount= 3,200.00 ***								
1612 Released	HACKLEMAN AUTO COLLISION REPAIR VEHICLE REPAIRS	8233	03/2026	03/12/2026	01/09/2026 03/12/2026	557.00	36134	1
01	1101.201.436.101		REPAIR AND MAINTENANCE			557.00	Expense	
1612 Released	HACKLEMAN AUTO COLLISION REPAIR SPORT TRUCK REPAIR	82869-001	03/2026	03/12/2026	06/15/2025 03/12/2026	1,000.00	36134	1
01	2211.501.431.116		MISC CONTRACTUAL			1,000.00	Expense	
*** Check-Number= 36134 Vendor Name= HACKLEMAN AUTO COLLISION REPAIR Check Date= 03/12/2026 Check Amount= 1,557.00 ***								
181 Released	ILMCT* 2026 DUES - KATHY TAYLOR	127661	03/2026	03/12/2026	02/25/2026 03/12/2026	82.00	36135	1
01	1101.102.413.110		OTHER TRAVEL TRAINING			82.00	Expense	
*** Check-Number= 36135 Vendor Name= ILMCT* Check Date= 03/12/2026 Check Amount= 82.00 ***								
2599 Released	INDIANA FIELD SUPPLIES LLC* FIELD SUPPLIES	2026-1070	03/2026	03/12/2026	02/24/2026 03/12/2026	4,809.44	36136	1
01	2211.501.422.101		OPERATING SUPPLIES			4,809.44	Expense	
*** Check-Number= 36136 Vendor Name= INDIANA FIELD SUPPLIES LLC* Check Date= 03/12/2026 Check Amount= 4,809.44 ***								
80 Released	INDIANA STREET COMMISSIONER'S MEMBERSHIP FOR 2026	2026 DUES	03/2026	03/12/2026	03/02/2026 03/12/2026	50.00	36137	1
01	2201.301.413.110		TRAVEL TRAINING			50.00	Expense	
*** Check-Number= 36137 Vendor Name= INDIANA STREET COMMISSIONER'S Check Date= 03/12/2026 Check Amount= 50.00 ***								
1898 Released	JTN SERVICES INC* EQUIPMENT INSTALL - NEW VEHICLE	30243	03/2026	03/12/2026	02/26/2026 03/12/2026	13,616.85	36138	1
01	4402.301.443.101		STREET IMPROVEMENTS			13,616.85	Expense	
1898 Released	JTN SERVICES INC* EQUIPMENT INSTALL - NEW VEHICLE	30242	03/2026	03/12/2026	02/26/2026 03/12/2026	13,616.85	36138	1
01	1101.201.422.101		LAW ENFORCEMENT SUPPLIES			13,616.85	Expense	
*** Check-Number= 36138 Vendor Name= JTN SERVICES INC* Check Date= 03/12/2026 Check Amount= 27,233.70 ***								
1406 Released	MOTOROLA SOLUTIONS* IN CAR VIDEO SYSTEM LICENSE (4)	1411236888	03/2026	03/12/2026	03/01/2026 03/12/2026	780.00	36139	1
01	4436.301.439.110		OTHER SERVICES & CHARGES			780.00	Expense	
1406 Released	MOTOROLA SOLUTIONS* BODY WORN CAMERA (79)	8282287856	03/2026	03/12/2026	02/27/2026 03/12/2026	1,580.00	36139	1
01	4436.301.439.110		OTHER SERVICES & CHARGES			1,580.00	Expense	

Check Register

Vendor Status Chk-Acct	Vendor Name Transaction-Description Account-Number	Invoice-No	Trans-mmyy PO-Number Liq	Due Date PO-Date	Invoice-Date Check-Date	Invoice-Total Amount	Claim-Number Check-Number	Remit-Addr
*** Check-Number= 36139 Vendor Name= MOTOROLA SOLUTIONS* Check Date= 03/12/2026 Check Amount= 2,360.00 ***								
1972 Released	NELSON & CO., LLC* UNIFORMS/30 SUPPS	SI181091	03/2026 2025-004 P	03/12/2026 01/15/2026	02/23/2026 03/12/2026	2,475.60	36140 1	
01	1101.201.422.101			LAW ENFORCEMENT SUPPLIES		2,475.60	Expense	
01	1101.201.422.101			LAW ENFORCEMENT SUPPLIES		2,475.60	Liquidation	
*** Check-Number= 36140 Vendor Name= NELSON & CO., LLC* Check Date= 03/12/2026 Check Amount= 2,475.60 ***								
511 Released	OFFICE 360* OFFICE SUPPLIES	3371647	03/2026	03/12/2026	02/23/2026 03/12/2026	159.34	36141 1	
01	1101.103.421.103			MISC SUPPLIES		139.34	Expense	
01	1101.102.421.103			MISC SUPPLIES		20.00	Expense	
*** Check-Number= 36141 Vendor Name= OFFICE 360* Check Date= 03/12/2026 Check Amount= 159.34 ***								
2915 Released	PRECISION GARAGE DOOR SERVICE* SERVICE CALL ONLY	264140813	03/2026	03/12/2026	02/26/2026 03/12/2026	188.00	36142 1	
01	1101.201.431.109			OTHER PROFESSIONAL SERVICE		188.00	Expense	
*** Check-Number= 36142 Vendor Name= PRECISION GARAGE DOOR SERVICE* Check Date= 03/12/2026 Check Amount= 188.00 ***								
2506 Released	PRIORITY WASTE* APD TRASH SERVICE	1693886	03/2026	03/12/2026	02/28/2026 03/12/2026	67.42	36143 1	
01	1101.103.435.101			UTILITIES		67.42	Expense	
2506 Released	PRIORITY WASTE* PARKS TRASH SERVICE	1693838	03/2026	03/12/2026	02/28/2026 03/12/2026	67.42	36143 1	
01	1101.103.435.101			UTILITIES		67.42	Expense	
2506 Released	PRIORITY WASTE* TOWN HALL TRASH SERVICE	1693924	03/2026	03/12/2026	02/28/2026 03/12/2026	67.42	36143 1	
01	1101.103.435.101			UTILITIES		67.42	Expense	
2506 Released	PRIORITY WASTE* TOWN HALL RECYCLE	1692265	03/2026	03/12/2026	02/28/2026 03/12/2026	70.56	36143 1	
01	1101.103.435.101			UTILITIES		70.56	Expense	
*** Check-Number= 36143 Vendor Name= PRIORITY WASTE* Check Date= 03/12/2026 Check Amount= 272.82 ***								
40 Released	REPUBLICAN NEWSPAPER*THE ZA25-03, DPR 25-21, 25-20, 25-18, 25-12	28756	03/2026	03/12/2026	02/21/2026 03/12/2026	122.54	36144 1	
01	1101.104.433.101			PRINTING ADVERTISING		122.54	Expense	
40 Released	REPUBLICAN NEWSPAPER*THE LEGAL NOTICE AFT TOWN	28887	03/2026	03/12/2026	03/03/2026 03/12/2026	132.83	36144 1	
01	1101.102.433.101			PRINTING PUBLICATIONS		132.83	Expense	

Check Register

A20260

JL

03/05/2026

17:21:37

Vendor Status Chk-Acct	Vendor Name Transaction-Description Account-Number	Invoice-No	Trans-mmyy PO-Number Account-Description	Due Date Liq PO-Date	Invoice-Date Check-Date	Invoice-Total Amount	Claim-Number Check-Number	Remit-Addr
40 Released	REPUBLICAN NEWSPAPER*THE LEGAL NOTICE AFR RDA	28886	03/2026	03/12/2026	03/03/2026 03/12/2026	70.19	36144	1
01	1101.102.433.101		PRINTING PUBLICATIONS			70.19	Expense	
40 Released	REPUBLICAN NEWSPAPER*THE LEGAL NOTICE FOR BIDS-CCMG 2026-1	28789	03/2026	03/12/2026	02/19/2026 03/12/2026	59.94	36144	1
01	1101.102.433.101		PRINTING PUBLICATIONS			59.94	Expense	
*** Check-Number= 36144 Vendor Name= REPUBLICAN NEWSPAPER*THE Check Date= 03/12/2026 Check Amount= 385.50 ***								
17 Released	SCHNEIDER GEOSPATIAL, LLC* HOSTING 04/01/2026 - 04/30/2026	I009738	03/2026	03/12/2026	03/01/2026 03/12/2026	792.70	36145	1
01	2201.301.439.108		GIS			792.70	Expense	
*** Check-Number= 36145 Vendor Name= SCHNEIDER GEOSPATIAL, LLC* Check Date= 03/12/2026 Check Amount= 792.70 ***								
1690 Released	SHRED-IT   STERICYCLE* SHREDDING SERVICES	8013452035	03/2026	03/12/2026	01/22/2026 03/12/2026	474.36	36146	1
01	1101.103.435.101		UTILITIES			474.36	Expense	
*** Check-Number= 36146 Vendor Name= SHRED-IT   STERICYCLE* Check Date= 03/12/2026 Check Amount= 474.36 ***								
105 Released	SIRCHIE ACQUISITION COMPANY, I HINGE LIFTER (2)	0733019-IN	03/2026	03/12/2026	02/27/2026 03/12/2026	40.60	36147	1
01	1101.201.422.101		LAW ENFORCEMENT SUPPLIES			40.60	Expense	
*** Check-Number= 36147 Vendor Name= SIRCHIE ACQUISITION COMPANY, I Check Date= 03/12/2026 Check Amount= 40.60 ***								
2704 Released	STEFANI, NICK* TOURNEY FEES 01/03/2026	02242026	03/2026	03/12/2026	02/24/2026 03/12/2026	552.00	36148	1
01	2211.501.422.101		OPERATING SUPPLIES			552.00	Expense	
*** Check-Number= 36148 Vendor Name= STEFANI, NICK* Check Date= 03/12/2026 Check Amount= 552.00 ***								
1974 Released	STELLO PRODUCTS, INC.* SIGNS	40349	03/2026	03/12/2026	02/18/2026 03/12/2026	1,751.00	36149	1
01	2201.301.439.110		OTHER SERVICES & CHARGES			1,751.00	Expense	
*** Check-Number= 36149 Vendor Name= STELLO PRODUCTS, INC.* Check Date= 03/12/2026 Check Amount= 1,751.00 ***								
2918 Released	STERICYCLE, INC.* ONSITE DOCUMENT SHREDDING	8013516265	03/2026	03/12/2026	02/25/2026 03/12/2026	205.00	36150	1
01	1101.201.431.109		OTHER PROFESSIONAL SERVICE			205.00	Expense	
*** Check-Number= 36150 Vendor Name= STERICYCLE, INC.* Check Date= 03/12/2026 Check Amount= 205.00 ***								
2530 Released	SUNBELT RENTALS, INC* TREE LIGHTING INSTALL/TAKEDOWN	178621673-0001	03/2026	03/12/2026	02/01/2026 03/12/2026	558.69	36151	1
01	4439.501.431.105		PROGRAMS & ACTIVITES			558.69	Expense	
*** Check-Number= 36151 Vendor Name= SUNBELT RENTALS, INC* Check Date= 03/12/2026 Check Amount= 558.69 ***								

Check Register

Vendor Status Chk-Acct	Vendor Name Transaction-Description Account-Number	Invoice-No	Trans-mmyy PO-Number	Due Date Liq PO-Date	Invoice-Date Check-Date	Invoice-Total Amount	Claim-Number Check-Number	Remit-Addr
581 Released	TAYLOR, MINNETTE, SCHNEIDER & ATTORNEY FEES	FEB 2026	03/2026	03/12/2026	02/25/2026 03/12/2026	27,791.25	36152	1
01	1101.301.431.101		LEGAL			114.00	Expense	
01	1101.201.431.101		LEGAL			3,901.50	Expense	
01	4445.301.431.101		PROFESSIONAL SERVICES			994.50	Expense	
01	1101.104.431.103		LEGAL			2,932.50	Expense	
01	1101.104.431.103		LEGAL			1,122.00	Expense	
01	1101.102.431.101		OTHER SERVICES - LEGAL			2,274.00	Expense	
01	1101.101.431.101		CONTRACTUAL SERVICE LEGAL			1,899.75	Expense	
01	4445.301.431.101		PROFESSIONAL SERVICES			152.50	Expense	
01	6501.301.431.101		LEGAL			739.50	Expense	
01	1101.201.431.101		LEGAL			76.50	Expense	
01	2201.301.431.103		MVH - LEGAL			153.00	Expense	
01	4445.301.431.101		PROFESSIONAL SERVICES			535.50	Expense	
01	1101.104.431.103		LEGAL			255.00	Expense	
01	4445.301.431.101		PROFESSIONAL SERVICES			7,246.00	Expense	
01	1101.104.411.107		BUILDING CODE ENFORCEMENT			178.50	Expense	
01	4445.301.431.101		PROFESSIONAL SERVICES			244.00	Expense	
01	1101.103.431.101		LEGAL			4,972.50	Expense	
*** Check-Number= 36152 Vendor Name= TAYLOR, MINNETTE, SCHNEIDER & Check Date= 03/12/2026						Check Amount=	27,791.25	***
2545 Released	TEAM SPORTS APPAREL* BASEBALL UNIFORMS	7286	03/2026	03/12/2026	02/25/2026 03/12/2026	4,122.00	36153	1
01	2211.501.422.101		OPERATING SUPPLIES			4,122.00	Expense	
2545 Released	TEAM SPORTS APPAREL* BACKPACKS, PATCHES & EMBROIDERY	7279	03/2026	03/12/2026	02/23/2026 03/12/2026	556.37	36153	1
01	2211.501.422.101		OPERATING SUPPLIES			556.37	Expense	
2545 Released	TEAM SPORTS APPAREL* BASEBALL PATCHES	7280	03/2026	03/12/2026	02/23/2026 03/12/2026	365.08	36153	1
01	2211.501.422.101		OPERATING SUPPLIES			365.08	Expense	
*** Check-Number= 36153 Vendor Name= TEAM SPORTS APPAREL* Check Date= 03/12/2026						Check Amount=	5,043.45	***
31 Released	TKO MARKETING SOLUTIONS, INC.* REMOVE DECAL SET - DODGE RAM	PSI0012310	03/2026	03/12/2026	02/24/2026 03/12/2026	95.00	36154	1
01	1101.201.436.101		REPAIR AND MAINTENANCE			95.00	Expense	
*** Check-Number= 36154 Vendor Name= TKO MARKETING SOLUTIONS, INC.* Check Date= 03/12/2026						Check Amount=	95.00	***
2466 Released	TRANSUNION RISK & ALTERNATIVE INVESTIGATIONS PROGRAM CONTRACT-FEBRUARY	6316412-2026021	03/2026	03/12/2026	03/01/2026 03/12/2026	120.00	36155	1
01	1101.201.431.109		OTHER PROFESSIONAL SERVICE			120.00	Expense	
*** Check-Number= 36155 Vendor Name= TRANSUNION RISK & ALTERNATIVE Check Date= 03/12/2026						Check Amount=	120.00	***
2829 Released	XEROX FINANCIAL SERVICES* CONTRACT	IN6365780	03/2026	03/12/2026	02/24/2026 03/12/2026	108.51	36156	1
01	1101.101.439.109		MISC. CONTRACTUAL			108.51	Expense	
*** Check-Number= 36156 Vendor Name= XEROX FINANCIAL SERVICES* Check Date= 03/12/2026						Check Amount=	108.51	***



Check Register

Vendor	Vendor Name	Invoice-No	Trans-mnyy	Due Date	Invoice-Date	Invoice-Total	Claim-Number
Status	Transaction-Description	PO-Number	Liq	PO-Date	Check-Date	Check-Number	Remit-Addr
Chk-Acct	Account-Number	Account-Description				Amount	Action

\*\*\* Run Totals \*\*\*

	Paid	Pre-Paid	Total
Check-Count	54.00		54.00

Invoice Total	297,958.06		297,958.06
Amount Paid	297,958.06		297,958.06
Amount Liquidated	15,699.22		15,699.22

Check Register

Vendor	Vendor Name	Invoice-No	Trans-mnyy	Due Date	Invoice-Date	Invoice-Total	Claim-Number
Status	Transaction-Description		PO-Number	Liq PO-Date	Check-Date		Check-Number
Chk-Acct	Account-Number		Account-Description			Amount	Remit-Addr
							Action

\*\*\* Bank Account Activity By Fund \*\*\*

Fund Description	Check Account	Cash-Account-Number	Regular	Pre-Paid	Total
GENERAL	01	1101.101.101.101	77,800.98		77,800.98
MOTOR VEHICLE HIGHWAY	01	2201.101.101.101	166,759.01		166,759.01
PARK RECREATION FUND	01	2211.101.101.101	20,855.16		20,855.16
CUMULATIVE CAPITAL DEVELOPMENT	01	4402.301.101.101	13,616.85		13,616.85
EDIT	01	4436.101.101.101	2,360.00		2,360.00
FOOD AND BEVERAGE FUND	01	4439.101.101.101	3,237.48		3,237.48
PARK IMPACT FEES	01	4443.501.101.101	3,416.58		3,416.58
TIF FUND	01	4445.301.101.101	9,172.50		9,172.50
STORM WATER OPERATING	01	6501.101.101.101	739.50		739.50
		*** Grand Totals ***	297,958.06		297,958.06

Funds Availability Report  
Expenditure AccountsA20300 JL  
03/05/2026 17:21:39

Account Vend-No	Vendor-Name	Account-Description Invoice-Description	Available-Balance Invoice-Number	Expense-Amount	Remaining-Balance	Enc	Over
1101.101.431.101 581	TAYLOR, MINNETTE, SCHNEIDER & C	CONTRACTUAL SERVICE LEGAL ATTORNEY FEES	37,991.00 FEB 2026	1,899.75	36,091.25		
1101.101.431.104 2717	1816 PUBLIC AFFAIRS GROUP, LLC*	OTHER PROFESSIONAL SERVICES SERVICE AGREEMENT 2026	79,300.00 5265	8,000.00	71,300.00		
1101.101.439.109 2829	XEROX FINANCIAL SERVICES*	MISC. CONTRACTUAL CONTRACT	-2,811.33 IN6365780	108.51	-2,919.84		****
1101.102.413.110 181	ILMCT*	OTHER TRAVEL TRAINING 2026 DUES - KATHY TAYLOR	4,000.00 127661	82.00	3,918.00		
1101.102.421.103 9 511	BOYCE FORMS/SYSTEMS* OFFICE 360*	MISC SUPPLIES RECEIPT BOOKS FOR CT OFFICE SUPPLIES	3,403.62 125759 3371647	614.80 20.00	2,788.82 2,768.82		
1101.102.431.101 581	TAYLOR, MINNETTE, SCHNEIDER & C	OTHER SERVICES - LEGAL ATTORNEY FEES	32,559.00 FEB 2026	2,274.00	30,285.00		
1101.102.433.101 40 40 40	REPUBLICAN NEWSPAPER*THE	PRINTING PUBLICATIONS LEGAL NOTICE FOR BIDS-CCMG 202 LEGAL NOTICE AFR RDA LEGAL NOTICE AFT TOWN	3,000.00 28789 28886 28887	59.94 70.19 132.83	2,940.06 2,869.87 2,737.04		
1101.103.413.115 2694	GINO GINO, ANGEL*	OTHER EMPLOYEE BENEFIT GYM REIMBURSEMENT	16,730.01 03042026	30.00	16,700.01		
1101.103.421.103 511 2207 2207	OFFICE 360* AMAZON CAPITAL SERVICES* AMAZON CAPITAL SERVICES*	MISC SUPPLIES OFFICE SUPPLIES ADMIN SUPPLIES ADMIN SUPPLIES	14,589.96 3371647 1JT6-9QMJ-1C9F 1RW3-34VG-JCJ4	139.34 60.58 158.97	14,450.62 14,390.04 14,231.07		
1101.103.431.101 581	TAYLOR, MINNETTE, SCHNEIDER & C	LEGAL ATTORNEY FEES	88,559.50 FEB 2026	4,972.50	83,587.00		
1101.103.432.105 2395	ENDEAVOR COMMUNICATIONS*	TELEPHONE UTILITIES	7,947.16 03012026	269.99	7,677.17		
1101.103.435.101 1690 2506 2506 2506 2506	SHRED-IT   STERICYCLE* PRIORITY WASTE* PRIORITY WASTE* PRIORITY WASTE* PRIORITY WASTE*	UTILITIES SHREDDING SERVICES TOWN HALL RECYCLE PARKS TRASH SERVICE APD TRASH SERVICE TOWN HALL TRASH SERVICE	9,431.15 8013452035 1692265 1693838 1693886 1693924	474.36 70.56 67.42 67.42 67.42	8,956.79 8,886.23 8,818.81 8,751.39 8,683.97		
1101.104.411.107 581	TAYLOR, MINNETTE, SCHNEIDER & C	BUILDING CODE ENFORCEMENT ATTORNEY FEES	25,654.73 FEB 2026	178.50	25,476.23		
1101.104.413.107 7	FINLEY* LAURA	CLOTHING ALLOWANCE REIMBURSEMENT FOR JEANS	3,149.59 02222026	54.00	3,095.59		
1101.104.431.103 581	TAYLOR, MINNETTE, SCHNEIDER & C	LEGAL ATTORNEY FEES	29,118.00 FEB 2026	4,309.50	24,808.50		
1101.104.433.101 40	REPUBLICAN NEWSPAPER*THE	PRINTING ADVERTISING ZA25-03, DPR 25-21, 25-20, 25-	4,113.37 28756	122.54	3,990.83		
1101.104.444.105 2207 2207	AMAZON CAPITAL SERVICES* AMAZON CAPITAL SERVICES*	COMPUTER EQUIPMENT LEATHER DESK PAD ART CANVAS	-656.55 19R7-VWXQ-4NL1 1YJW-4G6D-4FPD	13.29 46.77	-669.84 -716.61		**** ****

Funds Availability Report  
Expenditure Accounts

A20300 JL  
03/05/2026 17:21:39

Account	Account-Description	Available-Balance				
Vend-No	Vendor-Name	Invoice-Description	Invoice-Number	Expense-Amount	Remaining-Balance	Enc Over
1101.201.422.101	LAW ENFORCEMENT SUPPLIES	138,216.63				
105	SIRCHIE ACQUISITION COMPANY, IN	HINGE LIFTER (2)	0733019-IN	40.60	138,176.03	
930	AXON ENTERPRISE, INC*	TASET 90 HOLSTER (1)	INUS424397	88.58	138,087.45	
1898	JTN SERVICES INC*	EQUIPMENT INSTALL - NEW VEHICL	30242	13,616.85	124,470.60	
1972	NELSON & CO., LLC*	UNIFORMS/30 SUPPS	SI181091	2,475.60	124,470.60	Y
2027	COPPERHEAD RIDGE FIREARMS*	24 SOL LOWERS	1614	6,935.00	123,535.60	Y
2207	AMAZON CAPITAL SERVICES*	SUPPLIES	13WK-RY1F-VMVV	19.88	123,535.60	Y
2207	AMAZON CAPITAL SERVICES*	SUPPLIES	1CNN-NL7H-1HF7	52.14	123,535.60	Y
2207	AMAZON CAPITAL SERVICES*	SUPPLIES	1JDW-M9C1-71W3	72.57	123,535.60	Y
2207	AMAZON CAPITAL SERVICES*	SUPPLIES	1L1F-QHVL-TJMQ	23.69	123,535.60	Y
2207	AMAZON CAPITAL SERVICES*	SUPPLIES	1PJX-WMXF-7D7Y	9.49	123,535.60	Y
2207	AMAZON CAPITAL SERVICES*	SUPPLIES	1Q9K-F943-W1DX	41.78	123,535.60	Y
2207	AMAZON CAPITAL SERVICES*	SUPPLIES	1RFY-1M1K-V3NK	30.52	123,535.60	Y
2207	AMAZON CAPITAL SERVICES*	SUPPLIES	1T7F-N1R1-VRWJ	32.93	123,535.60	Y
2207	AMAZON CAPITAL SERVICES*	SUPPLIES	1TVV-1YQ6-CFPX	25.16	123,535.60	Y
2207	AMAZON CAPITAL SERVICES*	SUPPLIES	1VJK-NL7H-Y4K6	498.08	123,535.60	Y
2207	AMAZON CAPITAL SERVICES*	SUPPLIES	1XYT-YCN6-QRFV	131.33	123,535.60	Y
2207	AMAZON CAPITAL SERVICES*	SUPPLIES	1YQL-PF67-DJPK	142.47	123,535.60	Y
2635	EDGE-WORKS MANUFACTURING*	HOLSTER ADAPTOR FOR TASERS (9)	1336183	323.82	123,211.78	
1101.201.422.104	K-9 SUPPLIES	19,053.58				
1998	B & S BOARDING AND GROOMING*	KENNEL	APD01 2026	567.00	19,053.58	Y
2489	ACE K9*	ACE WATCHDOG SERVICE (5)	298767	840.00	18,213.58	
1101.201.431.101	LEGAL	6,943.00				
581	TAYLOR, MINNETTE, SCHNEIDER & C	ATTORNEY FEES	FEB 2026	3,978.00	2,965.00	
1101.201.431.109	OTHER PROFESSIONAL SERVICE	58,416.56				
2347	DONE AND DUSTED, LLC*	MARCH JANITORIAL	1390	1,462.50	56,954.06	
2466	TRANSUNION RISK & ALTERNATIVE D	INVESTIGATIONS PROGRAM CONTRAC	6316412-2026021	120.00	56,834.06	
2915	PRECISION GARAGE DOOR SERVICE*	SERVICE CALL ONLY	264140813	188.00	56,646.06	
2918	STERICYCLE, INC.*	ONSITE DOCUMENT SHREDDING	8013516265	205.00	56,441.06	
2943	FRONT LINE COUNSELING INC.*	COUNSELING	02182026	4,970.00	51,471.06	
1101.201.435.102	VEHICLE FUEL	152,166.67				
394	AVON COMMUNITY SCHOOL CORPORATI	VEHICLE FUEL FOR FEBRUARY	PD03032026	10,810.72	141,355.95	
1101.201.436.101	REPAIR AND MAINTENANCE	71,597.65				
31	TKO MARKETING SOLUTIONS, INC.*	REMOVE DECAL SET - DODGE RAM	PSI0012310	95.00	71,502.65	
1412	AUTOZONE, INC.*	MOTOR OIL	03582743129	18.60	71,484.05	
1612	HACKLEMAN AUTO COLLISION REPAIR	VEHICLE REPAIRS	8233	557.00	70,927.05	
2003	BEST ONE INDY*	TIRES (2)	1120052247	303.78	70,623.27	
2003	BEST ONE INDY*	TIRES (4)	1120052419	784.52	69,838.75	
2275	AUTO LAB*	OIL CHANGE	65166	69.29	69,769.46	
2275	AUTO LAB*	OIL CHANGE	65175	69.83	69,699.63	
2275	AUTO LAB*	OIL CHANGE	65198	69.93	69,629.70	
2764	D & D AUTO AND TOWING, LLC *	VEHICLE REPAIRS	19097-2	170.08	69,459.62	
2764	D & D AUTO AND TOWING, LLC *	DIFFERENTIAL, BATTERY	19297	2,249.49	67,210.13	
2764	D & D AUTO AND TOWING, LLC *	OXYGEN SENSOR	19441	284.04	66,926.09	
1101.301.431.101	LEGAL	17,059.00				
581	TAYLOR, MINNETTE, SCHNEIDER & C	ATTORNEY FEES	FEB 2026	114.00	16,945.00	
1101.301.435.102	UTILITY-VEHICLE FUEL	11,953.10				
394	AVON COMMUNITY SCHOOL CORPORATI	VEHICLE FUEL FOR FEBRUARY	TOFA03032026	948.53	11,004.57	
2201.301.413.110	TRAVEL TRAINING	2,854.60				
80	INDIANA STREET COMMISSIONER'S A	MEMBERSHIP FOR 2026	2026 DUES	50.00	2,804.60	
2201.301.431.103	MVH - LEGAL	14,828.00				
581	TAYLOR, MINNETTE, SCHNEIDER & C	ATTORNEY FEES	FEB 2026	153.00	14,675.00	

Funds Availability Report  
Expenditure Accounts

Account	Account-Description	Available-Balance					
Vend-No	Vendor-Name	Invoice-Description	Invoice-Number	Expense-Amount	Remaining-Balance	Enc	Over
2201.301.431.109	MVH CONTRACTUAL SERVICE		434,990.89				
189	FOX CONTRACTORS CORP*	SNOW EVENTS	61517	145,883.51	289,107.38		
189	FOX CONTRACTORS CORP*	SNOW REMOVAL	61534	11,365.00	277,742.38		
1083	ALL TERRAIN LANDSCAPE*	LIQUID SALT	409461	1,174.80	276,567.58		
1083	ALL TERRAIN LANDSCAPE*	LIQUID SALT	409487	250.00	276,317.58		
1815	BROOKFIELD SAND & GRAVEL, INC.*	FILL SAND	595293	5,089.00	271,228.58		
2201.301.435.101	REPAIRS & MAINTENANCE		194.63				
810	ERMCO, INC*	CONTROL BOX REPAIR	910026899	250.00	-55.37		****
2201.301.439.108	GIS		35,139.28				
17	SCHNEIDER GEOSPATIAL, LLC*	HOSTING 04/01/2026 - 04/30/202	1009738	792.70	34,346.58		
2201.301.439.110	OTHER SERVICES & CHARGES		22,584.82				
1974	STELLO PRODUCTS, INC.*	SIGNS	40349	1,751.00	20,833.82		
2211.501.421.105	OFFICE SUPPLIES		5,000.00				
599	EDWARDS EQUIPMENT COMPANY*	BACKPACK BLOWER PRO	01-18199	499.99	4,500.01		
2211.501.422.101	OPERATING SUPPLIES		186,176.42				
2544	DESTINATION ATHLETE OF INDIANA*	SOFTBALLS	1647	2,423.35	183,753.07		
2545	TEAM SPORTS APPAREL*	BACKPACKS, PATCHES & EMBROIDER	7279	556.37	183,196.70		
2545	TEAM SPORTS APPAREL*	BASEBALL PATCHES	7280	365.08	182,831.62		
2545	TEAM SPORTS APPAREL*	BASEBALL UNIFORMS	7286	4,122.00	178,709.62		
2599	INDIANA FIELD SUPPLIES LLC*	FIELD SUPPLIES	2026-1070	4,809.44	173,900.18		
2704	STEFANI, NICK*	TOURNEY FEES 01/03/2026	02242026	552.00	173,348.18		
2946	GRAND PARK FIELDHOUSE, LLC*	PROGRAMMING REGISTRATIONS	INV99978	3,200.00	170,148.18		
2211.501.431.116	MISC CONTRACTUAL		40,543.50				
1083	ALL TERRAIN LANDSCAPE*	AVON BALLFIELDS 104	409547	1,549.20	38,994.30		
1083	ALL TERRAIN LANDSCAPE*	AVON BALLFIELDS 866	409550	1,371.99	37,622.31		
1612	HACKLEMAN AUTO COLLISION REPAIR	SPORT TRUCK REPAIR	82869-001	1,000.00	36,622.31		
2484	CORVUS JANITORIAL OF INDIANAPOL	JANITORIAL SERVICES	603347003-0315	330.75	36,291.56		
2211.501.435.101	PARK REC UTILITES		10,722.60				
2945	FIDES COMMUNICATION*	OFFICE PHONE/INTERNET	071511	74.99	10,647.61		
4402.301.443.101	STREET IMPROVEMENTS		427,000.00				
1898	JTN SERVICES INC*	EQUIPMENT INSTALL - NEW VEHICL	30243	13,616.85	413,383.15		
4436.301.439.110	OTHER SERVICES & CHARGES		138,959.37				
1406	MOTOROLA SOLUTIONS*	IN CAR VIDEO SYSTEM LICENSE (4	1411236888	780.00	138,179.37		
1406	MOTOROLA SOLUTIONS*	BODY WORN CAMERA (79)	8282287856	1,580.00	136,599.37		
4439.501.422.102	REPAIR & MAINTENANCE SUPPLIES		21,243.66				
2003	BEST ONE INDY*	OIL CHANGE & LIGHT BULB REPLAC	1120052244	102.98	21,140.68		
2003	BEST ONE INDY*	OIL CHANGE	1120052519	75.98	21,064.70		
4439.501.431.104	PROFESSIONAL SERVICES		40,000.00				
1980	CHICAGO TITLE COMPANY, LLC*	TITLE SEARCH-PICKLEBALL COURT	CTIN2600498	300.00	39,700.00		
4439.501.431.105	PROGRAMS & ACTIVITES		96,779.30				
2207	AMAZON CAPITAL SERVICES*	PICNIC EVENT	1PRQ-L4X7-36D3	39.83	96,739.47		
2530	SUNBELT RENTALS, INC*	TREE LIGHTING INSTALL/TAKEDOWN	178621673-0001	558.69	96,180.78		
4439.501.431.115	MISC CONSULTING						
901	BANNING ENGINEERING, P.C*	TRAIL DESIGN AJAA	2510175	2,160.00			Y
4443.501.411.103	OTHER PROFESSIONAL SERVICES		67,000.00				
1647	CHA*	BRIDGE	82869-002	3,416.58	67,000.00		Y

Funds Availability Report  
Expenditure Accounts

Account	Account-Description	Available-Balance				
Vend-No	Vendor-Name	Invoice-Description	Invoice-Number	Expense-Amount	Remaining-Balance	Enc Over
4445.301.431.101		PROFESSIONAL SERVICES				
581	TAYLOR, MINNETTE, SCHNEIDER & C	ATTORNEY FEES	24,668.20 FEB 2026	9,172.50	15,495.70	
6501.301.431.101		LEGAL				
581	TAYLOR, MINNETTE, SCHNEIDER & C	ATTORNEY FEES	11,985.00 FEB 2026	739.50	11,245.50	

Electronic Payment Register

Vendor Status Chk-Acct	Vendor Name Transaction-Description Account-Number	Invoice-No	Trans-mmyy PO-Number Liq Account-Description	Due Date PO-Date	E-Pay-Date	Invoice-Total Amount	Claim-Number E-Pay-Number Action	Remit-Addr
1912 E-Pay	AIM MEDICAL TRUST* FEBRUARY PREMIUMS	7845942	03/2026	03/12/2026	03/12/2026	116,863.10	1883 1	
01	1101.104.413.105		GROUP INSURANCE			5,422.01	Expense	
01	4439.501.413.105		GROUP INSURANCE			6,824.92	Expense	
01	1101.201.413.105		GROUP INSURANCE			62,008.55	Expense	
01	6501.301.413.105		GROUP INSURANCE			7,733.57	Expense	
01	1101.102.413.105		GROUP INSURANCE			2,180.91	Expense	
01	1101.103.413.105		GROUP INSURANCE			4,128.60	Expense	
01	4436.301.413.105		GROUP INSURANCE			711.97	Expense	
01	8901.000.301.000		MEDICAL INSURANCE			27,852.57	Liability	
***E-Pay-Number= 1883 Vendor Name= AIM MEDICAL TRUST* E-Pay Date= 03/12/2026						E-Pay Amount=	116,863.10	***
1326 E-Pay	FIRST MERCHANTS BANK* PAYROLL WITHHOLDING-CHECK DATE	7923039	03/2026	03/05/2026	03/05/2026	4,641.21	1890 1	
01	8901.000.501.000		HSA - EMPLOYEE			4,120.38	Liability	
01	4436.301.413.115		HSA TOWN CONTRIBUTIONS			520.83	Expense	
***E-Pay-Number= 1890 Vendor Name= FIRST MERCHANTS BANK* E-Pay Date= 03/05/2026						E-Pay Amount=	4,641.21	***
2312 E-Pay	INDIANA STATE CENTRAL COLLECTI PAYROLL WITHHOLDING-CHECK DATE	20260304-1	03/2026	03/04/2026	03/04/2026	974.00	1889 1	
01	8901.000.400.000		INSCCU - CHILD SUPPORT			974.00	Liability	
***E-Pay-Number= 1889 Vendor Name= INDIANA STATE CENTRAL COLLECTI E-Pay Date= 03/04/2026						E-Pay Amount=	974.00	***
479 E-Pay	INPRS* POLICE RETIREMENT	342026	03/2026	03/12/2026	03/12/2026	43,213.28	1891 1	
01	8901.000.503.000		PERF EMPLOYEE CONTRIBUTION			8,848.97	Liability	
01	8901.000.502.000		PERF TOWN CONTRIBUTION			34,364.31	Liability	
***E-Pay-Number= 1891 Vendor Name= INPRS* E-Pay Date= 03/12/2026						E-Pay Amount=	43,213.28	***
2309 E-Pay	INTERNAL REVENUE SERVICE* PAYROLL WITHHOLDING-CHECK DATE	20260304-1	03/2026	03/04/2026	03/04/2026	39,036.61	1888 1	
01	8901.000.201.000		FEDERAL TAX			21,657.67	Liability	
01	8901.000.202.000		SSTA EMPLOYER			8,774.98	Liability	
01	8901.000.203.000		SSTA EMPLOYEE			8,603.96	Liability	
***E-Pay-Number= 1888 Vendor Name= INTERNAL REVENUE SERVICE* E-Pay Date= 03/04/2026						E-Pay Amount=	39,036.61	***
375 E-Pay	LOWE'S HOME CENTERS, INC.* SUPPLIES	02252026	03/2026	03/05/2026	03/05/2026	1,611.14	1893 1	
01	4439.501.422.101		OPERATING SUPPLIES			1,063.55	Expense	
01	2201.301.439.110		OTHER SERVICES & CHARGES			274.04	Expense	
01	1101.201.422.101		LAW ENFORCEMENT SUPPLIES			2.45	Expense	
01	2211.501.422.101		OPERATING SUPPLIES			271.10	Expense	
***E-Pay-Number= 1893 Vendor Name= LOWE'S HOME CENTERS, INC.* E-Pay Date= 03/05/2026						E-Pay Amount=	1,611.14	***
154 E-Pay	NATIONWIDE RETIREMENT* PAYROLL WITHHOLDING-CHECK DATE	20260304-1	03/2026	03/04/2026	03/04/2026	14,777.05	1884 1	
01	8901.000.504.000		457 TOWN MATCH			9,716.72	Liability	
01	8901.000.504.000		457 TOWN MATCH			120.00	Liability	
01	8901.000.504.000		457 TOWN MATCH			456.09	Liability	

Electronic Payment Register

Vendor Status Chk-Acct	Vendor Name Transaction-Description Account-Number	Invoice-No	Trans-mmyy PO-Number	Due Date Liq PO-Date	Invoice-Total Amount	Claim-Number E-Pay-Number	Remit-Addr Action
01	8901.000.504.000		457 TOWN MATCH		741.57	Liability	
01	8901.000.504.000		457 TOWN MATCH		1,004.66	Liability	
01	8901.000.504.000		457 TOWN MATCH		534.96	Liability	
01	8901.000.504.000		457 TOWN MATCH		150.00	Liability	
01	8901.000.504.000		457 TOWN MATCH		436.98	Liability	
01	8901.000.504.000		457 TOWN MATCH		150.00	Liability	
01	8901.000.504.000		457 TOWN MATCH		535.97	Liability	
01	8901.000.504.000		457 TOWN MATCH		72.38	Liability	
01	8901.000.504.000		457 TOWN MATCH		857.72	Liability	

\*\*\*E-Pay-Number= 1884 Vendor Name= NATIONWIDE RETIREMENT\* E-Pay Date= 03/04/2026 E-Pay Amount= 14,777.05 \*\*\*

2944	WEX BANK*	110934746	03/2026	03/04/2026	1,180.22		
E-Pay	VEHICLE FUEL				03/04/2026	1892	1
01	1101.201.435.102		VEHICLE FUEL		1,180.22	Expense	

\*\*\*E-Pay-Number= 1892 Vendor Name= WEX BANK\* E-Pay Date= 03/04/2026 E-Pay Amount= 1,180.22 \*\*\*

Electronic Payment Register

Vendor	Vendor Name	Invoice-No	Trans-mnyy	Due Date	Invoice-Total	Claim-Number	
Status	Transaction-Description	PO-Number	Liq	PO-Date	E-Pay-Date	E-Pay-Number	Remit-Addr
Chk-Acct	Account-Number	Account-Description			Amount	Action	

\*\*\* Run Totals \*\*\*

Total

Electronic Payment-Count

8.00

Invoice Total

222,296.61

Amount Paid

222,296.61

Amount Liquidated

Electronic Payment Register

Vendor	Vendor Name	Invoice-No	Trans-mmyy	Due Date	Invoice-Total	Claim-Number	
Status	Transaction-Description	PO-Number	Liq	PO-Date	E-Pay-Date	E-Pay-Number	Remit-Addr
Chk-Acct	Account-Number	Account-Description			Amount	Action	

\*\*\* Bank Account Activity By Fund \*\*\*

Fund Description	Check Account	Cash-Account-Number	Total
GENERAL	01	1101.101.101.101	74,922.74
MOTOR VEHICLE HIGHWAY	01	2201.101.101.101	274.04
PARK RECREATION FUND	01	2211.101.101.101	271.10
EDIT	01	4436.101.101.101	1,232.80
FOOD AND BEVERAGE FUND	01	4439.101.101.101	7,888.47
STORM WATER OPERATING	01	6501.101.101.101	7,733.57
PAYROLL FUND	01	8901.101.101.101	129,973.89
		*** Grand Totals ***	222,296.61

Funds Availability Report  
 Expenditure Accounts

Account Vend-No	Account-Description Vendor-Name	Invoice-Description	Available-Balance Invoice-Number	Expense-Amount	Remaining-Balance	Enc	Over
1101.102.413.105 1912	AIM MEDICAL TRUST*	GROUP INSURANCE FEBRUARY PREMIUMS	21,127.18 7845942	2,180.91	18,946.27		
1101.103.413.105 1912	AIM MEDICAL TRUST*	GROUP INSURANCE FEBRUARY PREMIUMS	48,439.80 7845942	4,128.60	44,311.20		
1101.104.413.105 1912	AIM MEDICAL TRUST*	GROUP INSURANCE FEBRUARY PREMIUMS	58,637.07 7845942	5,422.01	53,215.06		
1101.201.413.105 1912	AIM MEDICAL TRUST*	GROUP INSURANCE FEBRUARY PREMIUMS	755,787.90 7845942	62,008.55	693,779.35		
1101.201.422.101 375	LOWE'S HOME CENTERS, INC.*	LAW ENFORCEMENT SUPPLIES SUPPLIES	138,216.63 02252026	2.45	138,214.18		
1101.201.435.102 2944	WEX BANK*	VEHICLE FUEL VEHICLE FUEL	152,166.67 110934746	1,180.22	150,986.45		
2201.301.439.110 375	LOWE'S HOME CENTERS, INC.*	OTHER SERVICES & CHARGES SUPPLIES	22,584.82 02252026	274.04	22,310.78		
2211.501.422.101 375	LOWE'S HOME CENTERS, INC.*	OPERATING SUPPLIES SUPPLIES	186,176.42 02252026	271.10	185,905.32		
4436.301.413.105 1912	AIM MEDICAL TRUST*	GROUP INSURANCE FEBRUARY PREMIUMS	25,886.83 7845942	711.97	25,174.86		
4436.301.413.115 1326	FIRST MERCHANTS BANK*	HSA TOWN CONTRIBUTIONS PAYROLL WITHHOLDING-CHECK DATE	73,750.00 7923039	520.83	73,229.17		
4439.501.413.105 1912	AIM MEDICAL TRUST*	GROUP INSURANCE FEBRUARY PREMIUMS	117,603.69 7845942	6,824.92	110,778.77		
4439.501.422.101 375	LOWE'S HOME CENTERS, INC.*	OPERATING SUPPLIES SUPPLIES	18,232.50 02252026	1,063.55	17,168.95		
6501.301.413.105 1912	AIM MEDICAL TRUST*	GROUP INSURANCE FEBRUARY PREMIUMS	20,639.93 7845942	7,733.57	12,906.36		

TOWN OF AVON  
Funds Availability Report  
Cash Accounts

Account	Account-Description	Beginning-Balance	Total-Disbursed	Ending-Balance	Over
1101.101.101.101	GENERAL CASH	10,836,284.22	74,922.74	10,761,361.48	
2201.101.101.101	MVH CASH	3,315,883.43	274.04	3,315,609.39	
2211.101.101.101	PARK REC. CASH	143,028.20	271.10	142,757.10	
4436.101.101.101	EDIT CASH	1,244,346.96	1,232.80	1,243,114.16	
4439.101.101.101	FOOD BEV CASH	3,298,772.94	7,888.47	3,290,884.47	
6501.101.101.101	STORM WATER CASH	1,854,900.16	7,733.57	1,847,166.59	
8901.101.101.101	CHECKING - PAYROLL FUND	139,934.13	129,973.89	9,960.24	

Remaining Appropriation Test: Passed  
Cash Availability Test: Passed  
\*\*\*\*\* Tests: Passed

Check Register

Vendor Status Chk-Acct	Vendor Name Transaction-Description Account-Number	Invoice-No	Trans-mmyy PO-Number Liq PO-Date	Due Date PO-Date	Invoice-Date Check-Date	Invoice-Total Amount	Claim-Number Check-Number	Remit-Addr
768 Released	AES INDIANA* UTILITIES	02232026	03/2026	03/05/2026	02/23/2026 03/05/2026	512.70	36098	1
01	1101.301.435.101		UTILITY-ELECTRICITY			512.70	Expense	
*** Check-Number= 36098 Vendor Name= AES INDIANA* Check Date= 03/05/2026 Check Amount= 512.70 ***								
144 Released	DUKE ENERGY* UTILITIES	02252026-4	03/2026	03/05/2026	02/25/2026 03/05/2026	1,171.18	36099	1
01	1101.103.435.101		UTILITIES			1,171.18	Expense	
144 Released	DUKE ENERGY* UTILITIES	02252026-3	03/2026	03/05/2026	02/25/2026 03/05/2026	61.01	36099	1
01	1101.301.435.101		UTILITY-ELECTRICITY			61.01	Expense	
144 Released	DUKE ENERGY* UTILITIES	02252026-2	03/2026	03/05/2026	02/25/2026 03/05/2026	1,678.12	36099	1
01	4439.501.435.101		PARK UTILITES			1,405.96	Expense	
01	2211.501.435.101		PARK REC UTILITES			272.16	Expense	
144 Released	DUKE ENERGY* UTILITIES	02252026-1	03/2026	03/05/2026	02/25/2026 03/05/2026	1,060.19	36099	1
01	1101.201.435.101		POLICE STATION UTILITIES			1,060.19	Expense	
144 Released	DUKE ENERGY* UTILITIES	02242026-2	03/2026	03/05/2026	02/24/2026 03/05/2026	2,376.06	36099	1
01	1101.103.435.101		UTILITIES			2,376.06	Expense	
144 Released	DUKE ENERGY* UTILITIES	02242026	03/2026	03/05/2026	02/24/2026 03/05/2026	246.01	36099	1
01	1101.301.435.101		UTILITY-ELECTRICITY			246.01	Expense	
144 Released	DUKE ENERGY* UTILITIES	02232026	03/2026	03/05/2026	02/23/2026 03/05/2026	582.24	36099	1
01	1101.301.435.101		UTILITY-ELECTRICITY			582.24	Expense	
144 Released	DUKE ENERGY* UTILITIES	02262026-3	03/2026	03/12/2026	02/26/2026 03/05/2026	366.22	36099	1
01	1101.301.435.101		UTILITY-ELECTRICITY			366.22	Expense	
144 Released	DUKE ENERGY* UTILITIES	02262026-2	03/2026	03/12/2026	02/26/2026 03/05/2026	76.33	36099	1
01	1101.103.435.101		UTILITIES			76.33	Expense	
144 Released	DUKE ENERGY* UTILITIES	02262026-1	03/2026	03/12/2026	02/26/2026 03/05/2026	252.28	36099	1
01	2211.501.435.101		PARK REC UTILITES			252.28	Expense	

Check Register

Vendor Status Chk-Acct	Vendor Name Transaction-Description Account-Number	Invoice-No	Trans-mmyy PO-Number	Due Date Liq PO-Date	Invoice-Date Check-Date	Invoice-Total Amount	Claim-Number Check-Number	Remit-Addr
144 Released	DUKE ENERGY* UTILITIES	02272026	03/2026	03/12/2026	02/27/2026 03/05/2026	214.99	36099	1
01	1101.301.435.101		UTILITY-ELECTRICITY			214.99	Expense	
144 Released	DUKE ENERGY* UTILITIES	03022026	03/2026	03/12/2026	03/02/2026 03/05/2026	31.93	36099	1
01	1101.301.435.101		UTILITY-ELECTRICITY			31.93	Expense	
144 Released	DUKE ENERGY* UTILITIES	03052026	03/2026	03/12/2026	03/05/2026 03/05/2026	429.68	36099	1
01	2211.501.435.101		PARK REC UTILITES			429.68	Expense	
*** Check-Number= 36099 Vendor Name= DUKE ENERGY* Check Date= 03/05/2026						Check Amount=	8,546.24	***
1397 Released	HENDRICKS COUNTY CLERK OF THE CAUSE #32D05-2406-CC-001596	20260304-1	03/2026	03/04/2026	03/04/2026 03/05/2026	359.53	36100	1
01	8901.000.405.000		GARNISHMENT			359.53	Liability	
*** Check-Number= 36100 Vendor Name= HENDRICKS COUNTY CLERK OF THE Check Date= 03/05/2026						Check Amount=	359.53	***
1004 Released	HENDRICKS POWER COOPERATIVE* UTILITIES	02172026	03/2026	03/05/2026	02/17/2026 03/05/2026	878.18	36101	1
01	1101.301.435.101		UTILITY-ELECTRICITY			454.53	Expense	
01	2211.501.435.101		PARK REC UTILITES			423.65	Expense	
*** Check-Number= 36101 Vendor Name= HENDRICKS POWER COOPERATIVE* Check Date= 03/05/2026						Check Amount=	878.18	***
2874 Released	U.S. DEPARTMENT OF THE TREASUR TRACKING NUMBER - WG2736277	20260304-1	03/2026	03/04/2026	03/04/2026 03/05/2026	317.18	36102	1
01	8901.000.405.000		GARNISHMENT			317.18	Liability	
*** Check-Number= 36102 Vendor Name= U.S. DEPARTMENT OF THE TREASUR Check Date= 03/05/2026						Check Amount=	317.18	***

Check Register

Vendor	Vendor Name	Invoice-No	Trans-mmy	Due Date	Invoice-Date	Invoice-Total	Claim-Number
Status	Transaction-Description	PO-Number	Liq	PO-Date	Check-Date	Check-Number	Remit-Addr
Chk-Acct	Account-Number	Account-Description				Amount	Action

\*\*\* Run Totals \*\*\*

	Paid	Pre-Paid	Total
Check-Count	5.00		5.00

Invoice Total	10,613.83		10,613.83
Amount Paid	10,613.83		10,613.83
Amount Liquidated			

Check Register

Vendor	Vendor Name	Invoice-No	Trans-mmy	Due Date	Invoice-Date	Invoice-Total	Claim-Number
Status	Transaction-Description		PO-Number	Liq PO-Date	Check-Date		Check-Number
Chk-Acct	Account-Number		Account-Description			Amount	Remit-Addr
						Action	

\*\*\* Bank Account Activity By Fund \*\*\*

Fund Description	Check Account	Cash-Account-Number	Regular	Pre-Paid	Total
GENERAL	01	1101.101.101.101	7,153.39		7,153.39
PARK RECREATION FUND	01	2211.101.101.101	1,377.77		1,377.77
FOOD AND BEVERAGE FUND	01	4439.101.101.101	1,405.96		1,405.96
PAYROLL FUND	01	8901.101.101.101	676.71		676.71
		*** Grand Totals ***	10,613.83		10,613.83

Funds Availability Report  
 Expenditure Accounts

Account Vend-No	Vendor-Name	Account-Description Invoice-Description	Available-Balance Invoice-Number	Expense-Amount	Remaining-Balance	Enc	Over
1101.103.435.101		UTILITIES	9,431.15				
144	DUKE ENERGY*	UTILITIES	02242026-2	2,376.06	7,055.09		
144	DUKE ENERGY*	UTILITIES	02252026-4	1,171.18	5,883.91		
144	DUKE ENERGY*	UTILITIES	02262026-2	76.33	5,807.58		
1101.201.435.101		POLICE STATION UTILITIES	17,907.91				
144	DUKE ENERGY*	UTILITIES	02252026-1	1,060.19	16,847.72		
1101.301.435.101		UTILITY-ELECTRICITY	30,392.22				
144	DUKE ENERGY*	UTILITIES	02232026	582.24	29,809.98		
144	DUKE ENERGY*	UTILITIES	02242026	246.01	29,563.97		
144	DUKE ENERGY*	UTILITIES	02252026-3	61.01	29,502.96		
144	DUKE ENERGY*	UTILITIES	02262026-3	366.22	29,136.74		
144	DUKE ENERGY*	UTILITIES	02272026	214.99	28,921.75		
144	DUKE ENERGY*	UTILITIES	03022026	31.93	28,889.82		
768	AES INDIANA*	UTILITIES	02232026	512.70	28,377.12		
1004	HENDRICKS POWER COOPERATIVE*	UTILITIES	02172026	454.53	27,922.59		
2211.501.435.101		PARK REC UTILITES	10,722.60				
144	DUKE ENERGY*	UTILITIES	02252026-2	272.16	10,450.44		
144	DUKE ENERGY*	UTILITIES	02262026-1	252.28	10,198.16		
144	DUKE ENERGY*	UTILITIES	03052026	429.68	9,768.48		
1004	HENDRICKS POWER COOPERATIVE*	UTILITIES	02172026	423.65	9,344.83		
4439.501.435.101		PARK UTILITES	22,425.65				
144	DUKE ENERGY*	UTILITIES	02252026-2	1,405.96	21,019.69		

Funds Availability Report  
Cash Accounts

Account	Account-Description	Beginning-Balance	Total-Disbursed	Ending-Balance	Over
1101.101.101.101	GENERAL CASH	10,836,284.22	7,153.39	10,829,130.83	
2211.101.101.101	PARK REC. CASH	143,028.20	1,377.77	141,650.43	
4439.101.101.101	FOOD BEV CASH	3,298,772.94	1,405.96	3,297,366.98	
8901.101.101.101	CHECKING - PAYROLL FUND	139,934.13	676.71	139,257.42	

Remaining Appropriation Test: Passed  
Cash Availability Test: Passed  
\*\*\*\*\* Tests: Passed

Electronic Payment Register

Vendor Status Chk-Acct	Vendor Name Transaction-Description Account-Number	Invoice-No	Trans-mmy PO-Number	Due Date Liq PO-Date	Invoice-Total E-Pay-Date	Claim-Number E-Pay-Number	Remit-Addr
2853 E-Pay	ELAN* OPERATING SUPPLIES, TRAVEL AND TRAINING	FEB2026	02/2026	02/26/2026	9,728.78 02/26/2026	2262026	1
01	2240.101.413.110			PUBLIC SAFETY TRAVEL TRAINING	1,875.00	Expense	
01	2240.101.421.105			EMERGENCY RESPONSE TEAM	19.25	Expense	
01	2211.501.422.101			OPERATING SUPPLIES	3,529.82	Expense	
01	4439.501.431.105			PROGRAMS & ACTIVITES	20.07	Expense	
01	4439.501.413.107			CLOTHING ALLOWANCE	165.17	Expense	
01	4439.501.413.110			TRAVEL TRAINING	370.00	Expense	
01	4439.501.413.110			TRAVEL TRAINING	97.98	Expense	
01	1101.103.432.107			PROMOTIONAL	354.25	Expense	
01	1101.103.439.103			DUES AND SUBSCRIPTIONS	5.00	Expense	
01	1101.103.439.109			MISC CONTRACTUAL	14.99	Expense	
01	2201.301.413.107			CLOTHING ALLOWANCE	346.89	Expense	
01	2201.301.439.110			OTHER SERVICES & CHARGES	904.03	Expense	
01	2201.301.413.110			TRAVEL TRAINING	49.37	Expense	
01	1101.103.421.103			MISC SUPPLIES	22.95	Expense	
01	2201.301.413.110			TRAVEL TRAINING	475.00	Expense	
01	4439.501.422.101			OPERATING SUPPLIES	1,479.01	Expense	

\*\*\*E-Pay-Number= 2262026 Vendor Name= ELAN\* E-Pay Date= 02/26/2026 E-Pay Amount= 9,728.78 \*\*\*

2625 E-Pay	EVENTLINK* OFFICIALS/REFEREES/UMPIRES	02232026	02/2026	02/23/2026	9,000.00 02/23/2026	22326	1
01	2211.501.411.107			OFFICIALS / REFEREES	9,000.00	Expense	

\*\*\*E-Pay-Number= 22326 Vendor Name= EVENTLINK\* E-Pay Date= 02/23/2026 E-Pay Amount= 9,000.00 \*\*\*

2625 E-Pay	EVENTLINK* OFFICIALS/REFEREES/UMPIRES	232026	02/2026	02/03/2026	9,000.00 02/03/2026	232026	1
01	2211.501.411.107			OFFICIALS / REFEREES	9,000.00	Expense	

\*\*\*E-Pay-Number= 232026 Vendor Name= EVENTLINK\* E-Pay Date= 02/03/2026 E-Pay Amount= 9,000.00 \*\*\*

2625 E-Pay	EVENTLINK* OFFICIALS/REFEREES/UMPIRES	292026	02/2026	02/09/2026	9,000.00 02/09/2026	2092026	1
01	2211.501.411.107			OFFICIALS / REFEREES	9,000.00	Expense	

\*\*\*E-Pay-Number= 2092026 Vendor Name= EVENTLINK\* E-Pay Date= 02/09/2026 E-Pay Amount= 9,000.00 \*\*\*

Electronic Payment Register

A25500

JL

03/04/2026 16:56:26

Vendor	Vendor Name	Invoice-No	Trans-Num	Due Date	Invoice-Total	Claim-Number	
Status	Transaction-Description	PO-Number	Liq	PO-Date	E-Pay-Date	E-Pay-Number	Remit-Addr
Chk-Acct	Account-Number	Account-Description			Amount	Action	

\*\*\* Run Totals \*\*\*

Total

Electronic Payment-Count

4.00

Invoice Total

36,728.78

Amount Paid

36,728.78

Amount Liquidated

Electronic Payment Register

A25500 JL  
03/04/2026 16:56:26

Vendor	Vendor Name	Invoice-No	Trans-mmyy	Due Date	Invoice-Total	Claim-Number
Status	Transaction-Description		PO-Number	Liq PO-Date	E-Pay-Date	E-Pay-Number
Chk-Acct	Account-Number		Account-Description		Amount	Action

\*\*\* Bank Account Activity By Fund \*\*\*

Fund Description	Check Account	Cash-Account-Number	Total
GENERAL	01	1101.101.101.101	397.19
MOTOR VEHICLE HIGHWAY	01	2201.101.101.101	1,775.29
PARK RECREATION FUND	01	2211.101.101.101	30,529.82
LIT PUBLIC SAFETY	01	2240.101.101.101	1,894.25
FOOD AND BEVERAGE FUND	01	4439.101.101.101	2,132.23
		*** Grand Totals ***	36,728.78

TOWN OF AVON  
Funds Availability Report  
Expenditure Accounts

Account Vend-No	Vendor-Name	Account-Description Invoice-Description	Available-Balance Invoice-Number	Expense-Amount	Remaining-Balance	Enc	Over
1101.103.421.103 2853	ELAN*	MISC SUPPLIES OPERATING SUPPLIES, TRAVEL AND	14,612.91 FEB2026	22.95	14,589.96		
1101.103.432.107 2853	ELAN*	PROMOTIONAL OPERATING SUPPLIES, TRAVEL AND	-855.72 FEB2026	354.25	-1,209.97		****
1101.103.439.103 2853	ELAN*	DUES AND SUBSCRIPTIONS OPERATING SUPPLIES, TRAVEL AND	4,110.00 FEB2026	5.00	4,105.00		
1101.103.439.109 2853	ELAN*	MISC CONTRACTUAL OPERATING SUPPLIES, TRAVEL AND	25,516.92 FEB2026	14.99	25,501.93		
2201.301.413.107 2853	ELAN*	CLOTHING ALLOWANCE OPERATING SUPPLIES, TRAVEL AND	700.86 FEB2026	346.89	353.97		
2201.301.413.110 2853	ELAN*	TRAVEL TRAINING OPERATING SUPPLIES, TRAVEL AND	3,378.97 FEB2026	524.37	2,854.60		
2201.301.439.110 2853	ELAN*	OTHER SERVICES & CHARGES OPERATING SUPPLIES, TRAVEL AND	23,488.85 FEB2026	904.03	22,584.82		
2211.501.411.107 2625	EVENTLINK*	OFFICIALS / REFEREES OFFICIALS/REFEREES/UMPIRES	77,000.00 02232026	9,000.00	68,000.00		
2625	EVENTLINK*	OFFICIALS/REFEREES/UMPIRES	232026	9,000.00	59,000.00		
2625	EVENTLINK*	OFFICIALS/REFEREES/UMPIRES	292026	9,000.00	50,000.00		
2211.501.422.101 2853	ELAN*	OPERATING SUPPLIES OPERATING SUPPLIES, TRAVEL AND	189,706.24 FEB2026	3,529.82	186,176.42		
2240.101.413.110 2853	ELAN*	PUBLIC SAFETY TRAVEL TRAINING OPERATING SUPPLIES, TRAVEL AND	51,310.00 FEB2026	1,875.00	49,435.00		
2240.101.421.105 2853	ELAN*	EMERGENCY RESPONSE TEAM OPERATING SUPPLIES, TRAVEL AND	4,975.00 FEB2026	19.25	4,955.75		
4439.501.413.107 2853	ELAN*	CLOTHING ALLOWANCE OPERATING SUPPLIES, TRAVEL AND	1,748.45 FEB2026	165.17	1,583.28		
4439.501.413.110 2853	ELAN*	TRAVEL TRAINING OPERATING SUPPLIES, TRAVEL AND	-716.67 FEB2026	467.98	-1,184.65		****
4439.501.422.101 2853	ELAN*	OPERATING SUPPLIES OPERATING SUPPLIES, TRAVEL AND	19,711.51 FEB2026	1,479.01	18,232.50		
4439.501.431.105 2853	ELAN*	PROGRAMS & ACTIVITES OPERATING SUPPLIES, TRAVEL AND	96,799.37 FEB2026	20.07	96,779.30		

Electronic Payment Update (A25600)

A25600 JL  
03/04/2026 16:57:46

## Run Totals - 2/2026

Transaction Type	Debit Amount Count (0)	Credit Amount Count (1)	Debit Rev Amount Count (2)	Credit Rev Amount Count (3)
Original Estimate Of Revenue (0)	.00	.00	.00	.00
Revisions To Revenue Est (1)	.00	.00	.00	.00
Period Revenue (2)	.00	.00	.00	.00
Original Appropriation (3)	.00	.00	.00	.00
Revision Orig Appropriation (4)	.00	.00	.00	.00
Appropriation Transfer (5)	.00	.00	.00	.00
Period Expense (6)	36,728.78 19	.00	.00	.00
Period Asset Posting (7)	.00	36,728.78 19	.00	.00
Period Liability Posting (8)	.00	.00	.00	.00
Encumbrance (9)	.00	.00	.00	.00
Carryover Transfers (10)	.00	.00	.00	.00
Proof Totals	36,728.78 19	36,728.78 19	.00	.00

\*\*\* Note: Transaction types 0, 1, 3, 4, 5 and 10 are notational items only and are not included in the proof total \*\*\*

Proof Total Equals .00 \* In Balance \*

Electronic Payment Register

Vendor Status Chk-Acct	Vendor Name Transaction-Description Account-Number	Invoice-No	Trans-mmyy PO-Number Liq PO-Date	Due Date	E-Pay-Date	Invoice-Total Amount	Claim-Number E-Pay-Number Action	Remit-Addr
2917 E-Pay	ARGENT INSTITUTIONAL TRUST COM LENNAR 2025A	2025A	02/2026	02/26/2026	02/24/2026	1,733.62	173362 1	
01	4445.301.438.101		LEASE RENTAL PAYMENTS			1,733.62	Expense	
***E-Pay-Number= 173362 Vendor Name= ARGENT INSTITUTIONAL TRUST COM E-Pay Date= 02/24/2026 E-Pay Amount= 1,733.62 ***								
303 E-Pay	CITIZENS ENERGY GROUP* WATER TAP IN FEE - CIVIC CENTER	CWSA0213255123	02/2026	02/20/2026	02/20/2026	30,000.00	213255123 1	
01	4445.301.431.101		PROFESSIONAL SERVICES			30,000.00	Expense	
***E-Pay-Number= 213255123 Vendor Name= CITIZENS ENERGY GROUP* E-Pay Date= 02/20/2026 E-Pay Amount= 30,000.00 ***								
479 E-Pay	INPRS* POLICE RETIREMENT	2202026	02/2026	02/26/2026	02/26/2026	41,203.36	1882 1	
01	8901.000.503.000		PERF EMPLOYEE CONTRIBUTION			8,437.39	Liability	
01	8901.000.502.000		PERF TOWN CONTRIBUTION			32,765.97	Liability	
***E-Pay-Number= 1882 Vendor Name= INPRS* E-Pay Date= 02/26/2026 E-Pay Amount= 41,203.36 ***								

Electronic Payment Register

A25500 JL  
03/04/2026 16:00:01

Vendor	Vendor Name	Invoice-No	Trans-mnyy	Due Date	Invoice-Total	Claim-Number
Status	Transaction-Description	PO-Number	Liq	PO-Date	E-Pay-Date	E-Pay-Number
Chk-Acct	Account-Number	Account-Description			Amount	Action

\*\*\* Run Totals \*\*\*

Total

Electronic Payment-Count

3.00

Invoice Total

72,936.98

Amount Paid

72,936.98

Amount Liquidated

Electronic Payment Register

A25500 JL  
03/04/2026 16:00:01

Vendor	Vendor Name	Invoice-No	Trans-mmyy	Due Date	Invoice-Total	Claim-Number
Status	Transaction-Description	PO-Number	Liq	PO-Date	E-Pay-Date	E-Pay-Number
Chk-Acct	Account-Number	Account-Description			Amount	Action

\*\*\* Bank Account Activity By Fund \*\*\*

Fund Description	Check Account	Cash-Account-Number	Total
TIF FUND	01	4445.301.101.101	31,733.62
PAYROLL FUND	01	8901.101.101.101	41,203.36
		*** Grand Totals ***	72,936.98

Funds Availability Report  
Expenditure Accounts

A20300 JL  
03/04/2026 16:00:01

Account Vend-No	Vendor-Name	Account-Description Invoice-Description	Available-Balance Invoice-Number	Expense-Amount	Remaining-Balance	Enc	Over
4445.301.431.101 303	CITIZENS ENERGY GROUP*	PROFESSIONAL SERVICES WATER TAP IN FEE - CIVIC CENTE	54,668.20 CWSA0213255123	30,000.00	24,668.20		
4445.301.438.101 2917	ARGENT INSTITUTIONAL TRUST COMP LENNAR 2025A	LEASE RENTAL PAYMENTS	1,240,816.00 2025A	1,733.62	1,239,082.38		

Run Totals - 2/2026

Transaction Type	Debit Amount Count (0)	Credit Amount Count (1)	Debit Rev Amount Count (2)	Credit Rev Amount Count (3)
Original Estimate Of Revenue (0)	.00	.00	.00	.00
Revisions To Revenue Est (1)	.00	.00	.00	.00
Period Revenue (2)	.00	.00	.00	.00
Original Appropriation (3)	.00	.00	.00	.00
Revision Orig Appropriation (4)	.00	.00	.00	.00
Appropriation Transfer (5)	.00	.00	.00	.00
Period Expense (6)	31,733.62 2	.00	.00	.00
Period Asset Posting (7)	.00	72,936.98 4	.00	.00
Period Liability Posting (8)	41,203.36 2	.00	.00	.00
Encumbrance (9)	.00	.00	.00	.00
Carryover Transfers (10)	.00	.00	.00	.00
Proof Totals	72,936.98 4	72,936.98 4	.00	.00

\*\*\* Note: Transaction types 0, 1, 3, 4, 5 and 10 are notational items only and are not included in the proof total \*\*\*

Proof Total Equals .00 \* In Balance \*

TOWN OF AVON  
INTERFACE SUMMARY REPORT

PAGE 1  
P50000 KS  
03/04/2026 09:56 AM

REFERENCE: ACCOUNT	INTERFACE DESCRIPTION: DESCRIPTION	PAYROLL-CHECK DATE AMOUNT	03/06/2026	INTERFACE INITIALS: KS INTERFACE DATE: 03/04/2026
1101.101.101.101	GENERAL CASH	238,108.52	CR	
1101.102.411.101	SALARY CLERK TREASURER	2,541.94		
1101.102.411.102	DEPUTY CLERK TREASURER	2,960.00		
1101.102.413.101	FICA MED EMPLOYER SHARE	377.93		
1101.102.413.103	RETIREMENT EMPLOYER SHARE	9,596.89		
1101.103.411.101	SALARY TOWN MANAGER	5,101.88		
1101.103.411.104	COMMUNICATIONS DEPARTMENT PAY	3,000.00		
1101.103.411.105	EXECUTIVE ADMIN ASSISTANT	2,832.74		
1101.103.413.101	FICA MED EMPLOYER SHARE	542.30		
1101.104.411.101	PLANNING/ BUILDING DIRECTOR	3,901.43		
1101.104.411.102	ASST. BUILDING COMMISSIONER	2,942.30		
1101.104.411.103	PLANNING DIRECTOR	3,535.68		
1101.104.411.104	PLANNING ADMIN ASST	1,808.00		
1101.104.411.107	BUILDING CODE ENFORCEMENT	1,083.60		
1101.104.411.108	PLANNING/ BUILDING TECH	2,279.21		
1101.104.411.111	SENIOR PLANNER	2,846.40		
1101.104.413.101	FICA MED EMPLOYER SHARE	1,406.09		
1101.201.411.101	POLICE OFFICERS	139,000.76		
1101.201.411.102	ADMIN ASST/ DET AIDE	5,481.61		
1101.201.411.104	OVERTIME	9,838.84		
1101.201.413.101	FICA MED EMPLOYER SHARE	2,666.61		
1101.201.413.103	RETIREMENT EMPLOYER SHARE	34,364.31		
2201.101.101.101	MVH CASH	9,531.12	CR	
2201.301.411.101	PUBLIC WORKS DIRECTOR	4,498.62		
2201.301.411.102	ASSET MANAGER / PW TECHNICIAN	2,812.86		
2201.301.411.104	PROJECT COORDINATOR	1,425.19		
2201.301.413.101	FICA MED EMPLOYER SHARE	794.45		
2211.101.101.101	PARK REC. CASH	12,733.22	CR	
2211.501.411.101	ADMIN ASSISTANT - SPORTS	2,384.25		
2211.501.411.102	FIELD TECHNICIAN	1,692.80		
2211.501.411.103	SPORTS OPERATIONS MANGER	2,980.76		
2211.501.411.105	SENIOR FIELD TECHNICIAN	2,064.85		
2211.501.411.106	SPORTS DIRECTOR	3,610.56		
2240.101.101.101	CASH - LIT PUBLIC SAFETY	6,403.20	CR	
2240.101.411.101	SALARIES & WAGES	6,403.20		
4436.101.101.101	EDIT CASH	221.84	CR	
4436.301.413.101	FICA	221.84		
4439.101.101.101	FOOD BEV CASH	20,827.11	CR	
4439.101.368.101	REIMBURSEMENT	103.07	CR	
4439.501.411.101	ASSISTANT PARK DIRECTOR	3,269.23		
4439.501.411.105	PROGRAMMER/EVENT COORDINATOR	2,320.00		
4439.501.411.106	PARK DIRECTOR	3,770.61		
4439.501.411.107	GROUNDKEEPERS	9,264.01		
4439.501.413.101	FICA MED EMPLOYER SHARE	2,306.33		
6501.101.101.101	STORM WATER CASH	9,317.60	CR	
6501.301.411.101	CLERK TREASURER	1,089.40		
6501.301.411.102	PUBLIC WORKS TECHNICIAN	1,320.00		
6501.301.411.103	PROJECT COORDINATOR	1,425.19		
6501.301.411.104	MS4 COORDINATOR	1,083.60		
6501.301.411.105	ASSET MANAGER	1,492.86		
6501.301.411.106	GIS TECHNICIAN	2,412.80		
6501.301.413.101	FICA	373.92		
6501.301.413.103	RETIREMENT	119.83		
8901.000.201.000	FEDERAL TAX	21,657.67	CR	
8901.000.202.000	SSTA EMPLOYER	8,774.98	CR	
8901.000.203.000	SSTA EMPLOYEE	8,603.96	CR	
8901.000.209.000	STATE TAX	7,422.46	CR	
8901.000.213.000	COUNTY TAX	4,053.26	CR	
8901.000.300.000	AFLAC INSURANCE	364.89	CR	
8901.000.301.000	MEDICAL INSURANCE	10,140.72	CR	
8901.000.302.000	VISION INSURANCE	595.13	CR	





**Burnett Park | Phase One**

May 2024





# WINTON MEADOWS

MAY 2024







Burnett Add A4 2 \$54,000

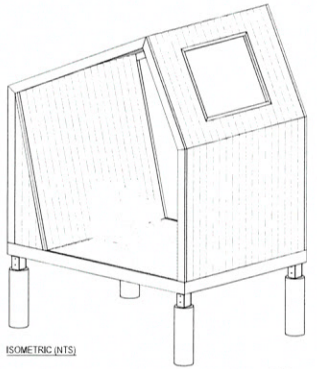

ISOMETRIC (NTS)

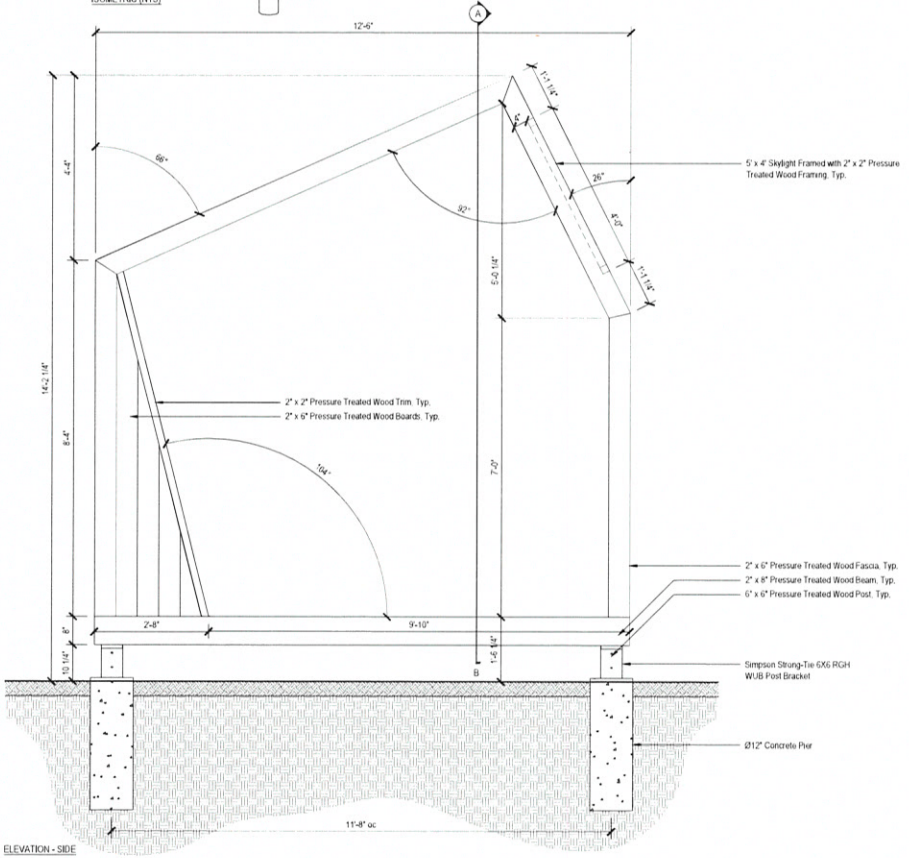

ELEVATION - SIDE

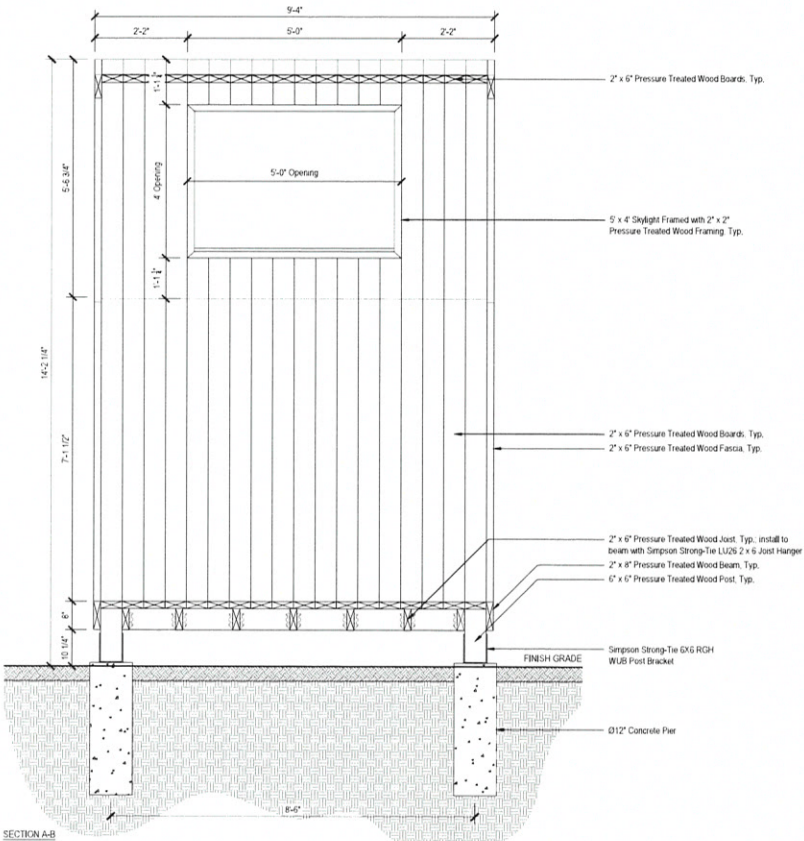

SECTION A-B

1 WOODLAND POD: SIDE ELEVATION, CROSS SECTION, AND ISOMETRIC  
Scale: 3/4" = 1'-0"

TOWN OF AVON  
PARKS AND REC  
**AVON**  
PARKS & REC

**context**  
DESIGN  
3025 Lovell Loop E. Dr. Elkhartville, IN 46124  
317-465-6000 | www.context-design.com

**krM**  
Architectural  
1915 N. Pennsylvania Street Indianapolis, Indiana 46240  
TEL 317-563-8800  
www.krmarchitect.com

**AMERICAN**  
**STRUCTUREPOINT**  
INC.  
905 River Road, Suite 200 Indianapolis, Indiana 46240  
TEL 317-547-0588 | FAX 317-543-0270  
www.structurepoint.com

**BURNETT PARK**

925 S County Road 800 E  
AVON, IN 46123



APPROVAL PENDING  
NOT FOR CONSTRUCTION  
BY EXAMINING THIS IN RELIANCE ON  
THESE PLANS THE CONTRACTOR  
ASSUMES ALL RISKS OF ADDITIONAL  
COSTS OF REVISIONS DUE TO  
REQUIREMENTS OF THE OWNER OR  
GOVERNMENTAL AUTHORITIES AND  
MATERIAL REVISIONS IN THE COURSE OF  
COMPLETING THE FINAL DESIGN.

CERTIFIED BY

ISSUANCE INDEX

DATE:	
8/18/25	
PROJECT PHASE:	
CONSTRUCTION DOCUMENTS	

REVISION SCHEDULE

NO.	DESCRIPTION	DATE
01	90% CD's	08/18/25

Project Number 2020.01413

SITE DETAILS

L519

Burnett Add Alt 3 \$89,500

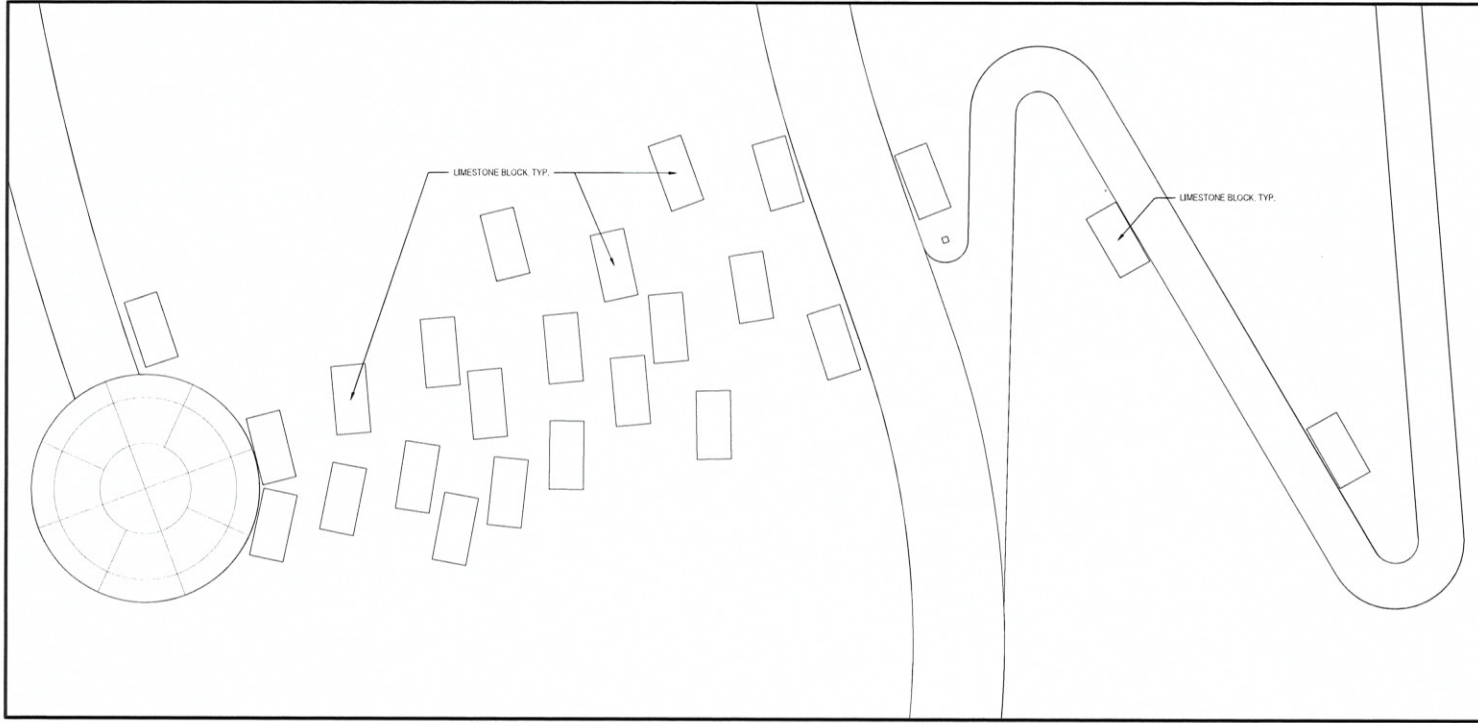

2 HILLSIDE LIMESTONE  
Scale: 1" = 5'-0"

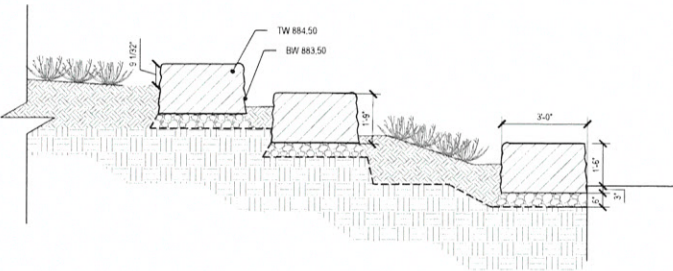

1 LIMESTONE OUTCROPPING  
Scale: 1/2" = 1'-0"

TOWN OF AVON  
PARKS AND REC  
**AVON**  
PARKS & REC

**context**  
DESIGN  
3025 Lovell Loop E, Lk. | Indianapolis, IN 46216  
317-485-4900 | www.context-design.com

**krM**  
ARCHITECTS  
15115 N. Pennsylvania Street | Indianapolis, Indiana 46240  
TEL: 317-268-8888  
www.krmarchitects.com

**AMERICAN**  
**STRUCTUREPOINT**  
INC.  
9025 River Road, Suite 200 | Indianapolis, Indiana 46240  
TEL: 317-547-5800 | FAX: 317-543-8270  
www.structurepoint.com

**BURNETT PARK**

925 S County Road 800 E  
AVON, IN 46123



APPROVAL PENDING  
NOT FOR CONSTRUCTION  
BY SUBMITTING THIS IN RELIANCE OF  
THESE PLANS THE CONTRACTOR  
ASSUMES ALL RISKS OF ADDITIONAL  
COSTS OF REVISIONS DUE TO  
REQUIREMENTS OF THE OWNER OR  
GOVERNMENTAL AUTHORITIES AND  
MATERIAL REVISIONS IN THE COURSE OF  
COMPLETING THE FINAL DESIGN.

CERTIFIED BY

ISSUANCE INDEX  
DATE:  
8/18/25  
PROJECT PHASE:  
CONSTRUCTION DOCUMENTS

REVISION SCHEDULE		
NO.	DESCRIPTION	DATE
01	90% CD's	08/18/25

Project Number 2020.01413

SITE DETAILS

L520

PLOT DATE: 8/11/2025 4:21 PM  
 FILE: L520.DWG  
 USER: JACOB  
 PLOT DATE: 8/11/2025  
 PLOT BY: JACOB  
 PLOT SCALE: 1/2"=1'-0"  
 PLOT SHEET: 1 OF 1  
 PROJECT: BURNETT PARK  
 PROJECT NUMBER: 2020.01413



# Pickleball and Burnett Shelter Buildings

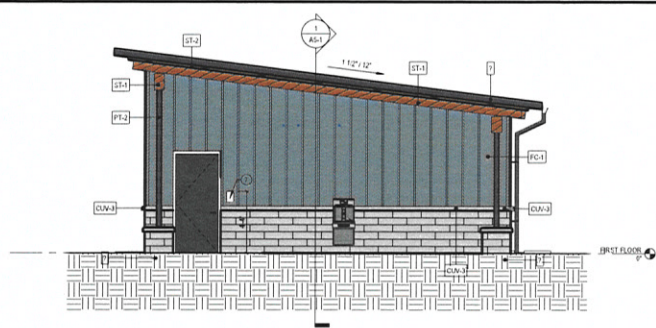

4 SOUTH ELEVATION  
SCALE: 1/4" = 1'-0"

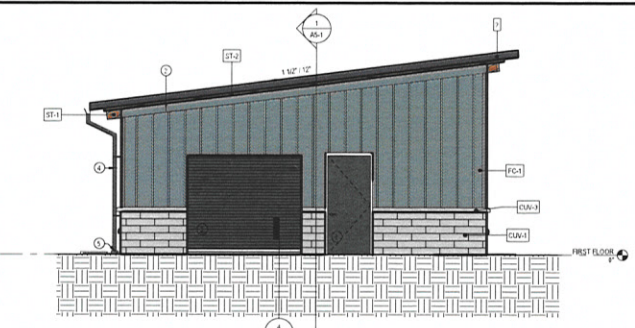

1 NORTH ELEVATION  
SCALE: 1/4" = 1'-0"

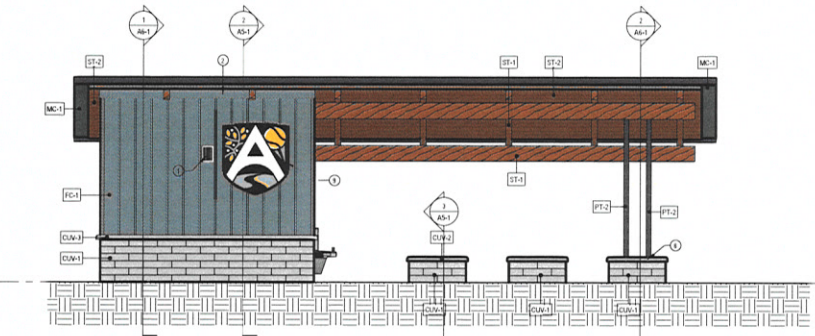

2 EAST ELEVATION  
SCALE: 1/4" = 1'-0"

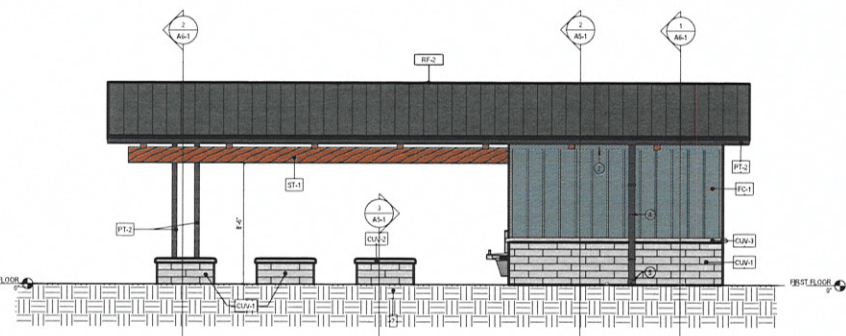

3 WEST ELEVATION  
SCALE: 1/4" = 1'-0"

### ELEVATION NOTES - EXTERIOR

- CENTER GIBBS BETWEEN BATTENS AND PAINT TO MATCH FIBER CEMENT COLOR.
- 2x4 FRAMING BY FIBER CEMENT PROVIDER. COLOR TO MATCH FC-1.
- PAINT OVERHEAD DOOR AND FRAME TO MATCH FIBER CEMENT COLOR.
- DOWNSPUT: PAINT TO MATCH MC-1. PROVIDE TWO STANDOFF (PROTECTIVE) BRACKETS EVERY 5 FEET TO SECURE BACK TO WALL.
- PAINT CAST IRON W/ FIBER CEMENT GEL BASED PRIMER AND FINAL COAT WITH OIL BASED ENAMEL PAINT (AVAILABLE FOR METAL). COLOR TO MATCH MC-1.
- DOOR AND FRAME COLOR TO MATCH FIBER CEMENT COLOR.
- SURFACE MOUNTED 4\"/>

EXTERIOR MATERIAL FINISH SCHEDULE						
MATERIAL TAG	MATERIAL TYPE	BASIS OF DESIGN/REF.	COLOR / TYPE	ADDITIONAL REMARKS	SPEC #	
CSA-1	GROUND FACE MASONRY	ECHOLON - CORDOVA THIN VENEER	GRANITE GROUND FACE - 2\"/>			



ADA COMPLIANT SIGNAGE FROM HIGH IMPACT ALUMINUM FOR EXTERIOR USE  
ADA COMPLIANT FONT AND TACTILE (1/32\"/>

5 ADA SIGNAGE TYP.  
SCALE: NTS

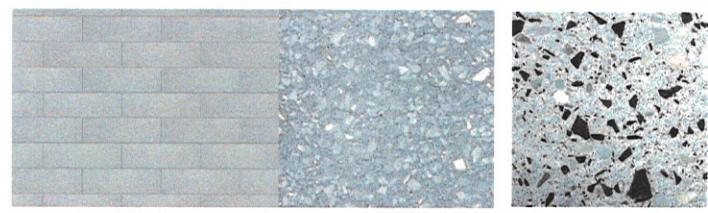
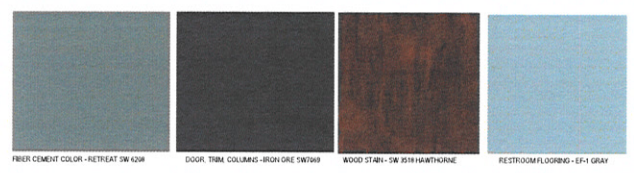

OVERALL PATTERN  
SAMPLE CLOSEUP  
CSA-1, CSA-2, CSA-3 FINISH EXTERIOR WALLS AND TRIM  
CSA-4 FINISH RESTROOM WALLS, STONE GRAY BURNISHED

6 EXTERIOR / INTERIOR COLOR SAMPLES  
SCALE: NTS

TOWNS OF AVON  
PARKS AND RECS



context  
DESIGN

1625 London Loop E. Dr. Indianapolis, IN 46216  
317-485-6300 | www.context-design.com



ANDERSON  
INDIANAPOLIS  
46216  
763.942.2477  
www.krmarchitect.com

SUB-CONSULTANT

BURNETT PARK

8264 E. County Road 100 S.  
Avon, IN 46123

APPROVAL PENDING  
NOT FOR CONSTRUCTION  
BY SUBMITTING THESE ELEVATIONS ON THESE PLANS THE CONTRACTOR AGREES ALL RISKS OF ACCIDENTAL COSTS OF REVISIONS DUE TO REQUIREMENTS OF THE OWNER OR GOVERNMENTAL AUTHORITIES ARE MATERIAL WITHIN THE COURSE OF COMPLETING THE FINAL DESIGN.

CERTIFIED BY

ISSUANCE INDEX	
DATE	
NO. 1629	
PROJECT PHASE	
PLAN COMPLETION	

REVISION SCHEDULE		
NO.	DESCRIPTION	DATE

Project Number 25022

DRAWN BY  
Author

DRAWING NAME  
EXTERIOR ELEVATIONS

DRAWING NO.  
A4-1

**MattCon & MacDougal Pierce and Alts**

---

<b>Burnett Base</b>	\$	3,185,000.00
Alt 01	\$	-
Alt 02	\$	-
Alt 03	\$	89,500.00
Alt 04	\$	111,000.00
Deduct	\$	-
Deduct	\$	(25,000.00)
<hr/>		
Total	\$	3,360,500.00
<b>Pickleball Base</b>	\$	1,142,670.00
Add Alternate	\$	49,000.00
Deduct	\$	-
Deduct	\$	(5,845.00)
Total	\$	1,185,825.00
<b>Grand Total</b>	<b>\$</b>	<b>4,546,325.00</b>

## Sources - Park Bond

<b>Sources - Park Bond</b>			
Park Bond			\$3,853,981
Food and Beverage 2026 Budget - 4439.501.444.101			\$190,000
Food and Beverage 2026 Budget - 4439.501.437.102			\$81,000
RIF Budget - 4443.501.422.101			\$210,000
Tree Mitigation Budget			\$60,000
			<b>\$4,394,981</b>

Uses - Park Bond			
		<b>Actual</b>	pd
			Bid
Utility Relocation			
Construction Burnett		\$ 3,360,500.00	
Construction Pickleball Courts		\$ 1,185,825.00	
Construction Winton Meadows		incl. w Burnett	
Construction contingency		incl. w bids	
Construction Observation			
Design Burnett and Winton Meadows		\$ -	
Design Pickel Ball		\$ -	
Rigdon Cma		\$ 250,000.00	
	<b>Total needed</b>	\$ 4,796,325.00	
	<b>Total Approved Sources</b>	\$ 4,394,980.75	
	<b>Difference</b>	\$401,344.25	
			\$ -
	created: 5/15/2024 RC		
	updated: 3/4/2026 SJP		

FUND REPORT - ALL FUNDS  
February 2026

Account Title Number	Beginning MTD Balance YTD Balance	MTD Debits YTD Debits	MTD Credits YTD Credits	Ending Balance	MTD Change YTD Change
2500 TREE MITIGATION FUND	150,785.59	0.00	0.00		0.00
	150,785.59	0.00	0.00	150,785.59	0.00
2501 LAW ENF RECORDING FEE	300.00	0.00	0.00		0.00
	300.00	0.00	0.00	300.00	0.00
2502 INFRASTRUCTURE CONT.	765,913.54	0.00	27,385.82		(27,385.82)
	772,692.54	3,500.00	37,664.82	738,527.72	(34,164.82)
3321 ROAD IMPRV. 2006 BOND	(5,694.68)	0.00	0.00		0.00
	121,896.82	0.00	127,591.50	(5,694.68)	(127,591.50)
3322 EDIT DS 2016	297,162.50	0.00	0.00		0.00
	297,162.50	0.00	0.00	297,162.50	0.00
3323 REDEV. BOND DSR	677,928.00	0.00	0.00		0.00
	677,928.00	0.00	0.00	677,928.00	0.00
3324 GO BOND 2024 DS	86,058.14	0.00	0.00		0.00
	126,058.14	0.00	40,000.00	86,058.14	(40,000.00)
4401 CUMULATIVE CAPITAL IMP.	209,614.05	0.00	0.00		0.00

FUND REPORT - ALL FUNDS  
February 2026

Account Title Number	Beginning MTD Balance YTD Balance	MTD Debits YTD Debits	MTD Credits YTD Credits	Ending Balance	MTD Change YTD Change
	209,614.05	0.00	0.00	209,614.05	0.00
4402 CUMULATIVE CAPITAL DEV.	2,192,598.27	0.00	61,462.45		(61,462.45)
	2,200,402.26	0.00	69,266.44	2,131,135.82	(69,266.44)
4418 FOOD & BEVERAGE BOND 2024	3,853,980.75	0.00	0.00		0.00
	3,853,980.75	0.00	0.00	3,853,980.75	0.00
4435 GO BOND 2024	3,526,454.64	0.00	6,631.35		(6,631.35)
	3,635,086.54	0.00	115,263.25	3,519,823.29	(115,263.25)
4436 EDIT	1,159,465.17	116,291.83	41,219.15		75,072.68
	1,420,904.79	233,333.66	419,700.60	1,234,537.85	(186,366.94)
4438 RAINY DAY FUND	1,530,987.90	150,000.00	0.00		150,000.00
	1,530,987.90	150,000.00	0.00	1,680,987.90	150,000.00
4439 FOOD & BEVERAGE FUND	3,227,191.65	178,685.58	107,249.42		71,436.16
	3,347,726.86	340,032.50	389,131.55	3,298,627.81	(49,099.05)
4443 PARK IMPACT FEES	1,052,599.51	6,003.00	38,312.02		(32,309.02)
	1,041,996.51	17,046.00	38,752.02	1,020,290.49	(21,706.02)

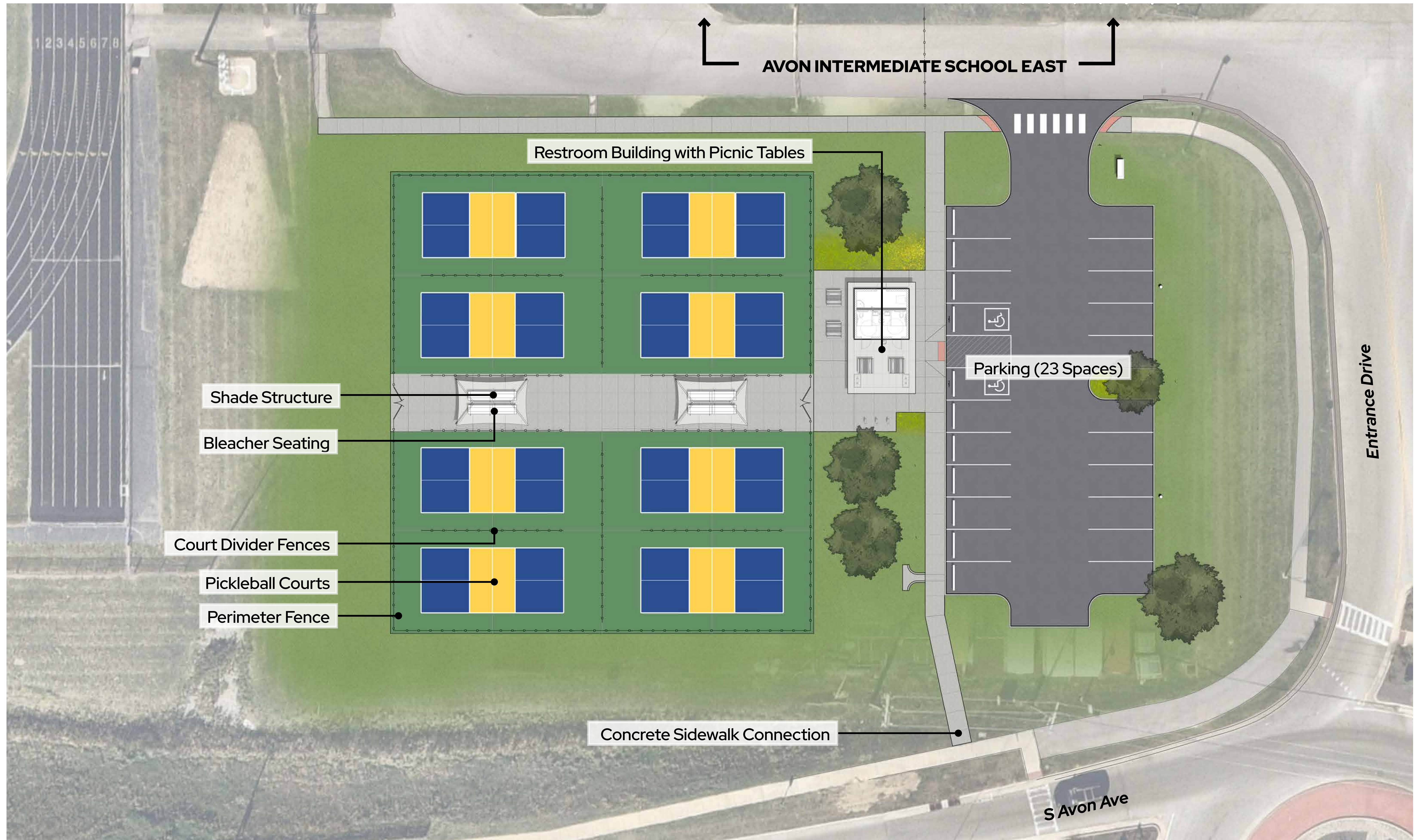

# AVON PICKLEBALL COURTS

Conceptual Design | July 2025

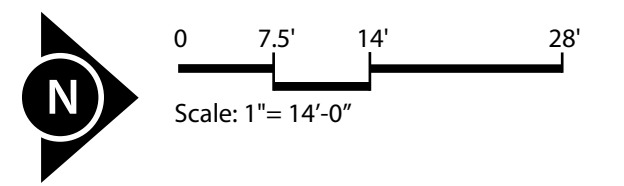

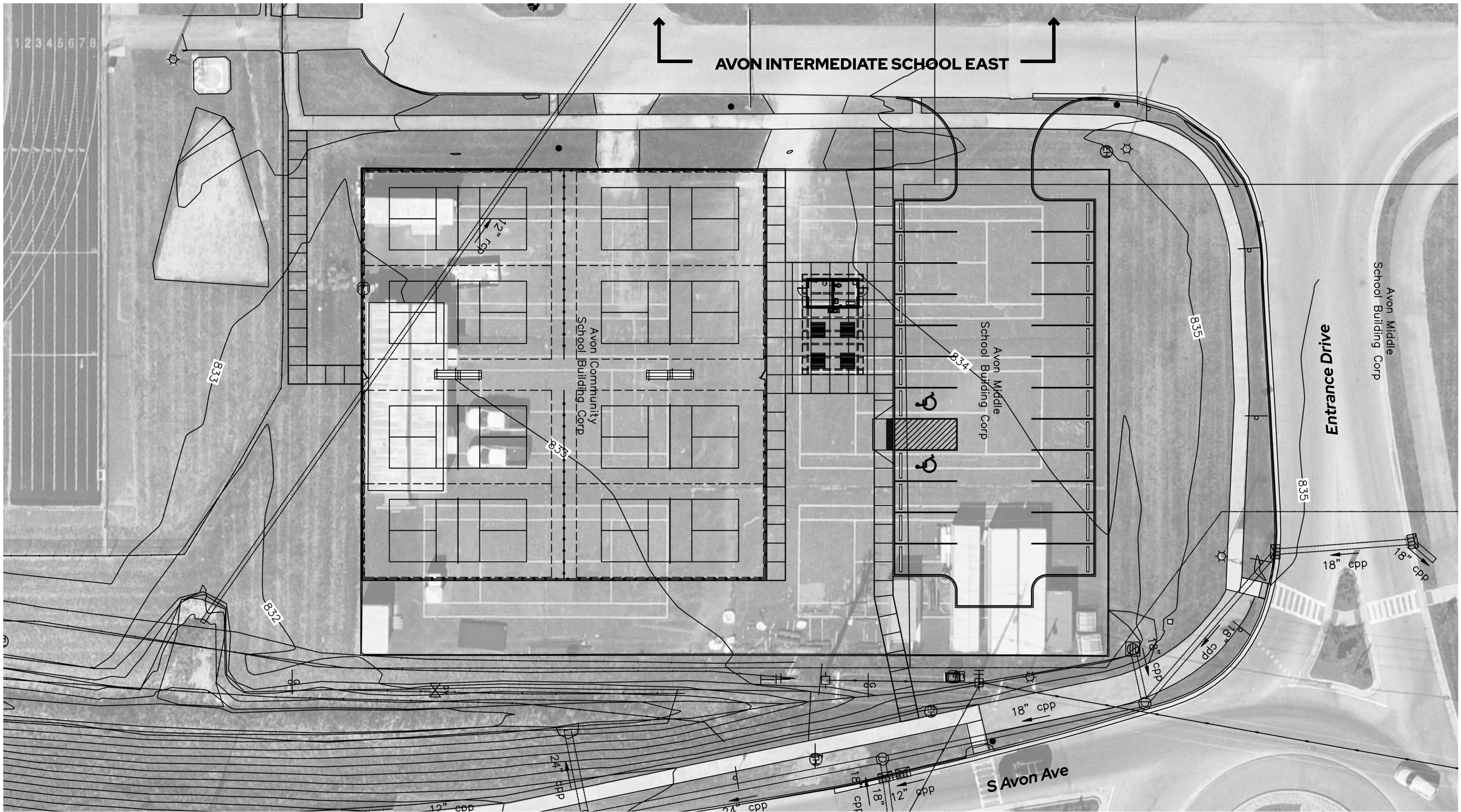

**AVON PICKLEBALL COURTS**  
 Conceptual Design | July 2025

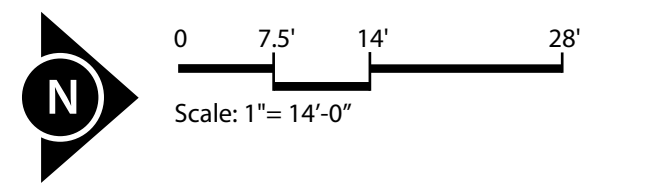

# AVON PARKS - Pickleball Park - Bid Tabs

	Bidders	Base Bid	Add Alternate 01	DEDUCT Alternate 01	DEDUCT Alternate 02	
1	JDH Contracting	\$1,947,719.30	\$50,000.00	\$0.00	\$0.00	\$1,997,719.30
2	First Due Company	\$1,537,000.00	\$43,110.00	\$0.00	\$0.00	\$1,580,110.00
3	MacDougall Pierce	\$1,142,670.00	\$49,000.00	\$0.00	-\$5,845.00	\$1,185,825.00
4	Pace Contracting	\$2,201,000.00	\$40,000.00	-\$50,000.00	\$0.00	\$2,241,000.00
5	Mattcon General Contracting	\$1,214,500.00	\$46,500.00	\$0.00	\$0.00	\$1,261,000.00
6	3D Professional Contracting	\$1,198,000.00	\$28,500.00	\$0.00	\$0.00	\$1,226,500.00
7	R Chavez Construction	\$1,483,152.00	\$42,000.00	\$0.00	\$0.00	\$1,525,152.00
8	Patterson Horth	\$1,344,000.00	\$61,000.00	\$0.00	\$0.00	\$1,405,000.00

**MattCon & MacDougal Pierce and Alts**

---

<b>Burnett Base</b>	\$	3,185,000.00
Alt 01	\$	-
Alt 02	\$	-
Alt 03	\$	89,500.00
Alt 04	\$	111,000.00
Deduct	\$	-
Deduct	\$	(25,000.00)
<hr/>		
Total	\$	3,360,500.00
<b>Pickleball Base</b>	\$	1,142,670.00
Add Alternate	\$	49,000.00
Deduct	\$	-
Deduct	\$	(5,845.00)
Total	\$	1,185,825.00
<b>Grand Total</b>	<b>\$</b>	<b>4,546,325.00</b>

## Sources - Park Bond

<b>Sources - Park Bond</b>			
Park Bond			\$3,853,981
Food and Beverage 2026 Budget - 4439.501.444.101			\$190,000
Food and Beverage 2026 Budget - 4439.501.437.102			\$81,000
RIF Budget - 4443.501.422.101			\$210,000
Tree Mitigation Budget			\$60,000
			<b>\$4,394,981</b>

Uses - Park Bond			
		<b>Actual</b>	pd
			Bid
Utility Relocation			
Construction Burnett		\$ 3,360,500.00	
Construction Pickleball Courts		\$ 1,185,825.00	
Construction Winton Meadows		incl. w Burnett	
Construction contingency		incl. w bids	
Construction Observation			
Design Burnett and Winton Meadows		\$ -	
Design Pickel Ball		\$ -	
Rigdon Cma		\$ 250,000.00	
	<b>Total needed</b>	\$ 4,796,325.00	
	<b>Total Approved Sources</b>	\$ 4,394,980.75	
	<b>Difference</b>	\$401,344.25	
			\$ -
	created: 5/15/2024 RC		
	updated: 3/4/2026 SJP		

FUND REPORT - ALL FUNDS  
February 2026

Account Title Number	Beginning MTD Balance YTD Balance	MTD Debits YTD Debits	MTD Credits YTD Credits	Ending Balance	MTD Change YTD Change
2500 TREE MITIGATION FUND	150,785.59	0.00	0.00		0.00
	150,785.59	0.00	0.00	150,785.59	0.00
2501 LAW ENF RECORDING FEE	300.00	0.00	0.00		0.00
	300.00	0.00	0.00	300.00	0.00
2502 INFRASTRUCTURE CONT.	765,913.54	0.00	27,385.82		(27,385.82)
	772,692.54	3,500.00	37,664.82	738,527.72	(34,164.82)
3321 ROAD IMPRV. 2006 BOND	(5,694.68)	0.00	0.00		0.00
	121,896.82	0.00	127,591.50	(5,694.68)	(127,591.50)
3322 EDIT DS 2016	297,162.50	0.00	0.00		0.00
	297,162.50	0.00	0.00	297,162.50	0.00
3323 REDEV. BOND DSR	677,928.00	0.00	0.00		0.00
	677,928.00	0.00	0.00	677,928.00	0.00
3324 GO BOND 2024 DS	86,058.14	0.00	0.00		0.00
	126,058.14	0.00	40,000.00	86,058.14	(40,000.00)
4401 CUMULATIVE CAPITAL IMP.	209,614.05	0.00	0.00		0.00

FUND REPORT - ALL FUNDS  
February 2026

Account Title Number	Beginning MTD Balance YTD Balance	MTD Debits YTD Debits	MTD Credits YTD Credits	Ending Balance	MTD Change YTD Change
	209,614.05	0.00	0.00	209,614.05	0.00
4402 CUMULATIVE CAPITAL DEV.	2,192,598.27	0.00	61,462.45		(61,462.45)
	2,200,402.26	0.00	69,266.44	2,131,135.82	(69,266.44)
4418 FOOD & BEVERAGE BOND 2024	3,853,980.75	0.00	0.00		0.00
	3,853,980.75	0.00	0.00	3,853,980.75	0.00
4435 GO BOND 2024	3,526,454.64	0.00	6,631.35		(6,631.35)
	3,635,086.54	0.00	115,263.25	3,519,823.29	(115,263.25)
4436 EDIT	1,159,465.17	116,291.83	41,219.15		75,072.68
	1,420,904.79	233,333.66	419,700.60	1,234,537.85	(186,366.94)
4438 RAINY DAY FUND	1,530,987.90	150,000.00	0.00		150,000.00
	1,530,987.90	150,000.00	0.00	1,680,987.90	150,000.00
4439 FOOD & BEVERAGE FUND	3,227,191.65	178,685.58	107,249.42		71,436.16
	3,347,726.86	340,032.50	389,131.55	3,298,627.81	(49,099.05)
4443 PARK IMPACT FEES	1,052,599.51	6,003.00	38,312.02		(32,309.02)
	1,041,996.51	17,046.00	38,752.02	1,020,290.49	(21,706.02)

# RIGDON CONSTRUCTION

March 6, 2026

Town of Avon  
6570 East US 36  
Avon, IN 46123

RE: CMA Services for Parks & Recreation Projects

Dear Mr. Ryan Cannon,

Rigdon Construction, Inc. proposes to provide Project Manager and Superintendent staffing for the Pickleball Park, Burnett Park, and Winton Meadows Park projects. Superintendent services will be billed at \$120.00 per hour, and Project Manager services will be billed at \$105.00 per hour, with total fees not to exceed \$250,000.00.

Respectfully,



Nate Rigdon, President  
Rigdon Construction, Inc.  
317-745-0033 | [nrigdon@rigdonconstruction.com](mailto:nrigdon@rigdonconstruction.com)





---

To: Ryan Cannon, Town Manager; Steve Moore, Public Works Director  
Cc: Avon Town Council

From: Keeton Olson, Asset Manager

Date: March 3<sup>rd</sup>, 2026

Re: 2026 Roadside Mowing

Avon Public Works contacted three landscaping contractors to perform roadside mowing operations for the Town.

The contract includes completing seven cycles of mowing our entire town's right-of-way; except locations on our roundabout contract, and the collection/disposal of all trash/debris before/throughout each mowing cycle. The project has 90 roadside miles (45 centerline); approximately 177 acres.

The Town's approved standard contract will be used for this project. Funding for this project will be taken from MVH funds, as usual.

The two quotation totals we received were as follows:

1. All-Terrain Landscape and Snow Management - \$18,412.00/ cycle (\$128,884.00/ 1 year)
2. Wild Ridge Lawn and Landscape - \$15,275/ cycle (\$106,925.00/ 1 year)
3. Integrity Outdoor Solutions – No Quote

**We recommends 'Wild Ridge Lawn and Landscape' to be awarded the 2026 Roadside Mowing Project in the amount of \$106,925.00 (or \$15,275.00) payment upon completion of each cycle).**

-The Request For Quotes is attached

If you have any further questions, please feel free to contact me at [kolson@avonindiana.gov](mailto:kolson@avonindiana.gov) or (317) 272-0948 ext. 129.



---

To: Interested Contractors

From: Keeton Olson, Asset Manager

Date: February 10<sup>th</sup>, 2026

Re: 2026 Roadside Mowing

Avon Public Works is receiving quotes for the following:

1. Contractor shall mow all right-of-way on Avon jurisdictional roads. Total mileage is approximately 45 centerline miles (90 roadside miles; 177 acres). Right-of-way will include roadside drainage swales, but exclude all protected native Indiana prairie areas; designated by 'DO NOT MOW OR SPRAY' signs (one pass, at least 42", on each side of the path will be required in these locations). If equipment cannot be used to mow the area of concern, the contractor will be expected to utilize weed eaters or other acceptable mowing equipment to maintain the area. Awarded contractor will weed eat around all structures in right-of-way excluding mailboxes. All curblines adjacent to mowing must be free of weeds, whether trimmed/sprayed or both. Seven monthly cycles of mowing are to be scheduled for each calendar year (May-November); contract may be extended by one year (up to three years consecutively) if mutually agreed upon. Contractor must be capable of satisfactorily mowing the entire area within the 10 day cycle timeframe, as well as any additional landscaping as needed. Contractor must own or lease at least 5 full commercial sized (zero-turn or comparable) mowers, 5 weed eaters, fertilizing/weed treatment equipment, suitable trimming equipment for larger foliage, and employ at least 5 employees to operate them. Contractor is to furnish a list of all employees, equipment, and materials they will utilize in their proposal.
2. Contractor shall collect and remove all trash and debris from all local roads before every mowing cycle. Contractor shall also provide separate pricing for road/roadside debris pickup on all jurisdictional roads, as well as US Hwy 36 from Old Main St to Raceway Rd. A price for deer/large animal pickup must also be provided.
3. Each cycle of debris pickup, trimming, and mowing shall be completed within 10 consecutive days, weather permitting, within the month that the cycle occurs.

**This project will be for a one-year contract**, extendable for up to three years. Submitted quotes must be a lump sum for the annual mowing contract, seven monthly cycles of mowing in 2026 and disposal of all material collected, with the amount for each cycle of mowing and each cycle of trash/debris removal listed for billing purposes. First mowing cycle is to be complete by Memorial Day weekend (the



---

weekend before the last Monday of May), third cycle complete for Independence Day (July 4<sup>th</sup>), fifth cycle to be complete for Labor Day (September 2<sup>nd</sup>), and last cycle to be complete before Winter. Hourly rates for on-call removal of large animals and on-call debris removal shall be provided. All quotes should be submitted no later than 12 pm on February 27<sup>th</sup>, 2026. See attached quotation example below.

If you have any further questions, please feel free to contact me at [kolson@avonindiana.gov](mailto:kolson@avonindiana.gov) or (317) 272-0948 ext. 129.



---

## Avon Roadside Mowing Project

### Quotation

#### Price per Cycle:

- |                                   |        |
|-----------------------------------|--------|
| 1. Mowing/trimming/trash removal- | \$X.XX |
| 2. Mowing/trimming/trash removal- | \$X.XX |
| 3. Mowing/trimming/trash removal- | \$X.XX |
| 4. Mowing/trimming/trash removal- | \$X.XX |
| 5. Mowing/trimming/trash removal- | \$X.XX |
| 6. Mowing/trimming/trash removal- | \$X.XX |
| 7. Mowing/trimming/trash removal- | \$X.XX |

Additional Services- \$X.XX

---

**Total:** **\$XX.XX**

Signed by \_\_\_\_\_ Signed by \_\_\_\_\_  
Contractor Town

# Avon 2026 Mowing Map

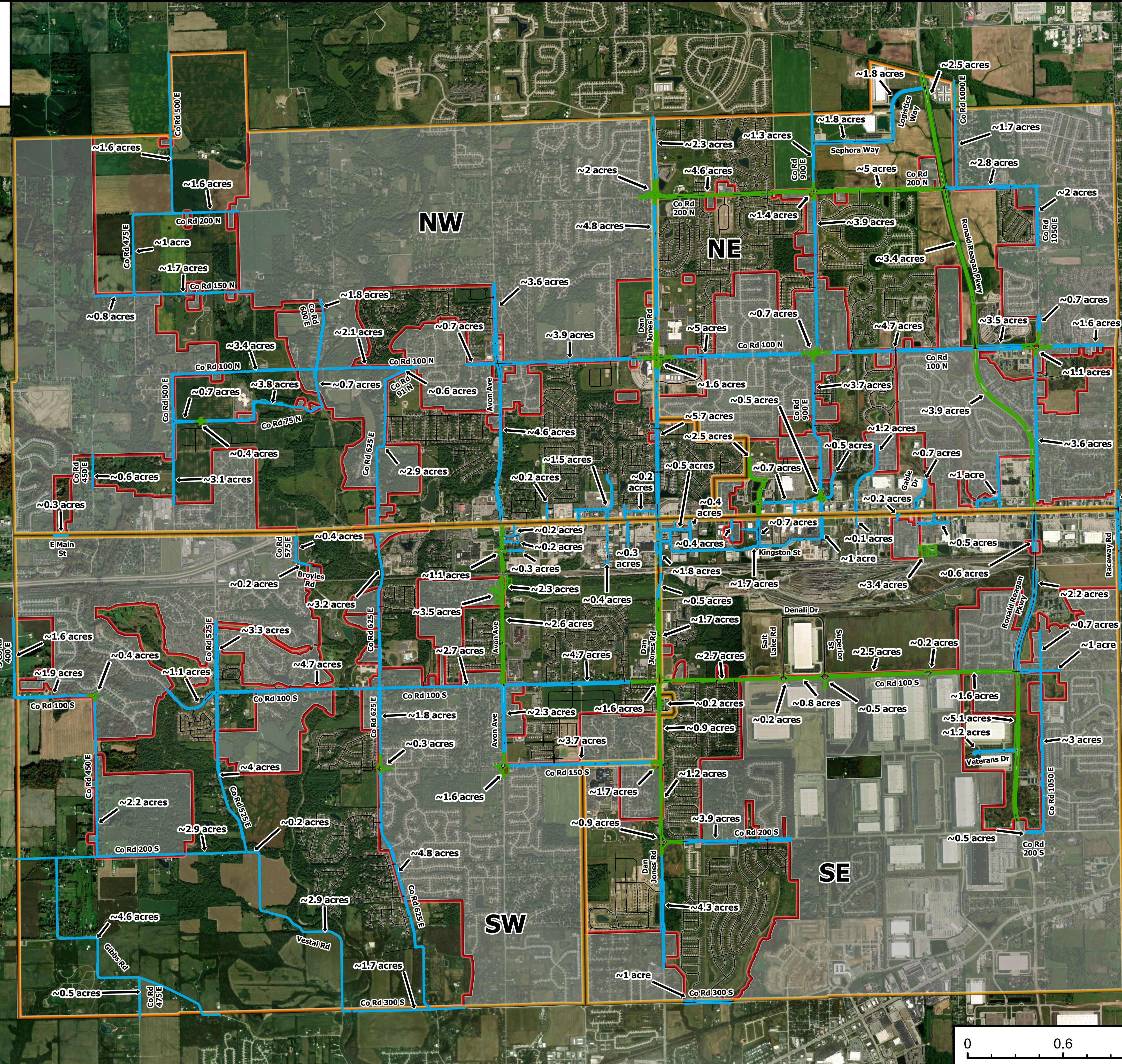
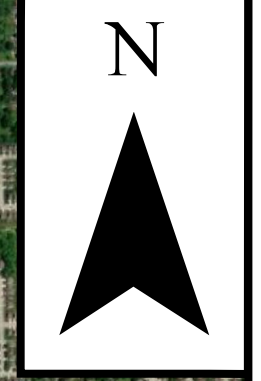

The total acreage to be mowed for the Roundabout Contract is approximately 65 acres, and the total acreage to be mowed for the ROW Contract is approximately 177 acres.

**Legend**

- ▬ ROW Contract
- ▬ Roundabout Contract
- ▬ Avon Corporate Boundary
- ▬ Washington Township
- Avon Streets
- ▬ Avon Quadrants

0      0.6      1.2      1.8      2.4 Miles



## Avon Roadside Mowing Project

### Quotation

#### Price per Cycle:

- |                                   |             |
|-----------------------------------|-------------|
| 1. Mowing/trimming/trash removal- | \$15,275.00 |
| 2. Mowing/trimming/trash removal- | \$15,275.00 |
| 3. Mowing/trimming/trash removal- | \$15,275.00 |
| 4. Mowing/trimming/trash removal- | \$15,275.00 |
| 5. Mowing/trimming/trash removal- | \$15,275.00 |
| 6. Mowing/trimming/trash removal- | \$15,275.00 |
| 7. Mowing/trimming/trash removal- | \$15,275.00 |

Additional Services- Deer / Large Animal Removal	\$300.00 ea.
--	--------------

---

<b>Total:</b>	<b>\$106,925.00</b>
---------------	---------------------

Signed by <u>Joe Wildridge</u> Contractor Wild Ridge Lawn & Landscape, LLC	Signed by _____ Town
--	-------------------------



# CERTIFICATE OF LIABILITY INSURANCE

DATE (MM/DD/YYYY)  
02/27/2026

THIS CERTIFICATE IS ISSUED AS A MATTER OF INFORMATION ONLY AND CONFERS NO RIGHTS UPON THE CERTIFICATE HOLDER. THIS CERTIFICATE DOES NOT AFFIRMATIVELY OR NEGATIVELY AMEND, EXTEND OR ALTER THE COVERAGE AFFORDED BY THE POLICIES BELOW. THIS CERTIFICATE OF INSURANCE DOES NOT CONSTITUTE A CONTRACT BETWEEN THE ISSUING INSURER(S), AUTHORIZED REPRESENTATIVE OR PRODUCER, AND THE CERTIFICATE HOLDER.

IMPORTANT: If the certificate holder is an ADDITIONAL INSURED, the policy(ies) must have ADDITIONAL INSURED provisions or be endorsed. If SUBROGATION IS WAIVED, subject to the terms and conditions of the policy, certain policies may require an endorsement. A statement on this certificate does not confer rights to the certificate holder in lieu of such endorsement(s).

<b>PRODUCER</b> Robley Insurance Services 801 Loews Blvd, Suite E  Greenwood IN 46142	<b>CONTACT NAME:</b> Angie Cook <b>PHONE (A/C, No, Ext):</b> (317) 865-0800 <b>E-MAIL ADDRESS:</b> angie@robleyinsurance.com	<b>FAX (A/C, No):</b> (317) 865-0898
	<b>INSURER(S) AFFORDING COVERAGE</b>	
<b>INSURED</b> Wild Ridge Lawn and Landscape LLC  3355 S Arlington Ave  Indianapolis IN 46203	<b>INSURER A:</b> Frankenmuth Insurance <span style="float:right">NAIC # 13986</span>	
	<b>INSURER B:</b>	
	<b>INSURER C:</b>	
	<b>INSURER D:</b>	
	<b>INSURER E:</b>	
	<b>INSURER F:</b>	

**COVERAGES** AC **CERTIFICATE NUMBER:** Cert ID 34234 (213) **REVISION NUMBER:**

THIS IS TO CERTIFY THAT THE POLICIES OF INSURANCE LISTED BELOW HAVE BEEN ISSUED TO THE INSURED NAMED ABOVE FOR THE POLICY PERIOD INDICATED. NOTWITHSTANDING ANY REQUIREMENT, TERM OR CONDITION OF ANY CONTRACT OR OTHER DOCUMENT WITH RESPECT TO WHICH THIS CERTIFICATE MAY BE ISSUED OR MAY PERTAIN, THE INSURANCE AFFORDED BY THE POLICIES DESCRIBED HEREIN IS SUBJECT TO ALL THE TERMS, EXCLUSIONS AND CONDITIONS OF SUCH POLICIES. LIMITS SHOWN MAY HAVE BEEN REDUCED BY PAID CLAIMS.

INSR LTR	TYPE OF INSURANCE	ADDL INSD	SUBR WVD	POLICY NUMBER	POLICY EFF (MM/DD/YYYY)	POLICY EXP (MM/DD/YYYY)	LIMITS
A	<input checked="" type="checkbox"/> <b>COMMERCIAL GENERAL LIABILITY</b> <input type="checkbox"/> CLAIMS-MADE <input checked="" type="checkbox"/> OCCUR  GEN'L AGGREGATE LIMIT APPLIES PER: <input type="checkbox"/> POLICY <input checked="" type="checkbox"/> PRO-JECT <input checked="" type="checkbox"/> LOC OTHER:			6667383	11/01/2025	11/01/2026	EACH OCCURRENCE \$ 1,000,000 DAMAGE TO RENTED PREMISES (Ea occurrence) \$ 1,000,000 MED EXP (Any one person) \$ 10,000 PERSONAL & ADV INJURY \$ 1,000,000 GENERAL AGGREGATE \$ 2,000,000 PRODUCTS - COM/OP AGG \$ 2,000,000
A	<b>AUTOMOBILE LIABILITY</b> <input checked="" type="checkbox"/> ANY AUTO <input type="checkbox"/> OWNED AUTOS ONLY <input type="checkbox"/> SCHEDULED AUTOS <input checked="" type="checkbox"/> HIRED AUTOS ONLY <input checked="" type="checkbox"/> NON-OWNED AUTOS ONLY			6667382	11/01/2025	11/01/2026	COMBINED SINGLE LIMIT (Ea accident) \$ 1,000,000 BODILY INJURY (Per person) \$ BODILY INJURY (Per accident) \$ PROPERTY DAMAGE (Per accident) \$
A	<input checked="" type="checkbox"/> <b>UMBRELLA LIAB</b> <input checked="" type="checkbox"/> OCCUR <input type="checkbox"/> EXCESS LIAB <input type="checkbox"/> CLAIMS-MADE DED RETENTION \$			6667383	11/01/2025	11/01/2026	EACH OCCURRENCE \$ 5,000,000 AGGREGATE \$ 5,000,000
A	<b>WORKERS COMPENSATION AND EMPLOYERS' LIABILITY</b> ANY PROPRIETOR/PARTNER/EXECUTIVE OFFICER/MEMBER EXCLUDED? (Mandatory In NH) <input type="checkbox"/> Y/N If yes, describe under DESCRIPTION OF OPERATIONS below		N/A	6667381	11/01/2025	11/01/2026	<input checked="" type="checkbox"/> PER STATUTE <input type="checkbox"/> OTH-ER E.L. EACH ACCIDENT \$ 1,000,000 E.L. DISEASE - EA EMPLOYEE \$ 1,000,000 E.L. DISEASE - POLICY LIMIT \$ 1,000,000
A	<b>Rented/Leased Equipment</b>			6667383	11/01/2025	11/01/2026	\$1000 ded \$ 200,000

DESCRIPTION OF OPERATIONS / LOCATIONS / VEHICLES (ACORD 101, Additional Remarks Schedule, may be attached if more space is required)  
RE: CCB Project: 225106, Town of McCordsville Community Center Conversion  
Certificate holder and Cushman & Wakefield are shown as additional insureds on a primary and non-contributory basis as required by written contract. Waiver of subrogation applies on GL and WC.

<b>CERTIFICATE HOLDER</b>	<b>CANCELLATION</b>
	SHOULD ANY OF THE ABOVE DESCRIBED POLICIES BE CANCELLED BEFORE THE EXPIRATION DATE THEREOF, NOTICE WILL BE DELIVERED IN ACCORDANCE WITH THE POLICY PROVISIONS.  AUTHORIZED REPRESENTATIVE <i>Angie Cook</i>



POWERED BY PASSION. DEDICATED TO DETAILS. ROOTED IN RELATIONSHIPS.

## WRlogistics

PREMIER SNOW & ICE RISK MITIGATION

Dear Mr. Olson, Town Manager, Public Works Director, and Members of the Avon Town Council,

On behalf of Wild Ridge Lawn & Landscape, I would like to sincerely thank the Town of Avon and Avon Public Works for the opportunity to submit our proposals for the 2026 Right-of-Way and Roundabout Mowing & Maintenance contracts.

We recognize the significance of these corridors. Avon's roundabouts, roadways, medians, and rights-of-way are among the most visible assets in the community, shaping first impressions for residents, businesses, and visitors alike. They require consistency, safety awareness, rapid response capability, and disciplined execution to meet strict 10-day cycle requirements and key holiday deadlines.

Wild Ridge is uniquely equipped to meet and exceed those expectations.

As a full-service commercial landscape contractor with extensive municipal and public-sector experience, we have the manpower, fleet capacity, and operational infrastructure necessary to perform this scope efficiently and reliably. We exceed the minimum equipment and staffing requirements outlined in the RFP and maintain dedicated crews specifically trained in large-scale roadside and right-of-way maintenance. Our operational systems are designed to ensure:

- Completion of each mowing, trimming, and debris cycle within the required 10-day window
- Proactive scheduling to meet Memorial Day, Independence Day, Labor Day, and pre-winter deadlines
- Strict adherence to protected "Do Not Mow or Spray" prairie zones
- Clean, well-defined curblines, splitter islands, roundabouts, and medians
- Safe operations along high-traffic corridors
- Immediate response capability for accidents, storm damage, large animal removal, and emergency debris situations

Our crews are trained to operate efficiently in active traffic environments, utilizing proper safety equipment and traffic-control best practices to maintain workflow while ensuring public safety and minimizing disruption.

Beyond routine maintenance, we would welcome the opportunity to serve as a long-term resource to the Town for future beautification initiatives that enhance both Avon and the experience of its residents. Our landscape design team is experienced in working within municipal budget parameters while identifying creative ways to maximize value—whether reallocating efficiencies within mowing services to fund enhancements or strategically phasing improvements over time. We bring extensive hands-on experience selecting durable, sustainable plant material specifically suited for roadway medians and roundabouts. A brief tour through the City of Fishers reflects our full capabilities, from thoughtful design and disciplined budgeting to quality execution and long-term maintenance stewardship.



POWERED BY PASSION. DEDICATED TO DETAILS. ROOTED IN RELATIONSHIPS.

## WRlogistics

PREMIER SNOW & ICE RISK MITIGATION

Please accept this letter and accompanying proposals as our formal submittal for the 2026 Roadside Mowing and 2026 Roundabout Maintenance RFPs. We have also included a photo collage highlighting our team and representative project work, along with a separate letter addressed to Town leadership expressing our appreciation for the opportunity.

This proposal represents far more than a number on paper — it reflects the knowledge, resources, operational discipline, and proven experience required to deliver the results the Town of Avon expects and deserves. Should you require any additional information during your review, please do not hesitate to contact us.

Thank you again for your consideration and for the opportunity to earn your trust. We would be honored to serve the Town of Avon in 2026 and beyond.

Respectfully submitted,

A handwritten signature in cursive script that reads "Joe Wildridge".

Joe Wildridge  
Founder / Owner  
Wild Ridge Lawn & Landscape / W.R. Logistics



POWERED BY PASSION. DEDICATED TO DETAILS. ROOTED IN RELATIONSHIPS.

## WRlogistics

PREMIER SNOW & ICE RISK MITIGATION

### Company Background & Experience

Wild Ridge Lawn & Landscape, LLC is a commercial grounds maintenance and snow/ice management firm headquartered in Indianapolis, IN. Since 2005, we have specialized in servicing commercial campuses, municipalities, institutional facilities, and multi-site portfolios, providing integrated programs that cover mowing, landscape care, snow removal, and de-icing.

Our portfolio includes corporate campuses, educational facilities, or large commercial properties, where we deliver year-round service under long-term contracts with defined performance standards.

### Staffing Levels

Wild Ridge currently employs approximately:

- 37 full-time employees
- 23 part-time/seasonal team members

Our full-time employees include operations leadership, account management, project managers, crew leaders, equipment operators, and support staff. Seasonal employees augment our capacity during peak mowing and winter months, and we maintain a cross-trained team of operators to ensure 24/7 coverage during snow events.

### Similar Projects

We have successfully completed and/or currently manage projects with scopes:

1. **City of Fishers, IN**
2. **City of Beech Grove, IN**
3. **Crew Carwash**
4. **Ivy Tech Community College— Indianapolis & Noblesville**

For each of these clients, Wild Ridge provides weekly mowing and trimming during the growing season, seasonal lawn applications, and 24/7 on-call snow and ice response with performance standards aligned to safety and accessibility requirements.

Public Works Maintenance Trends												
Activity	2018	2019	2020	2021	2022	2023	Actual 2024	Budget 2025	Budget 2026	Average 2022-2024	Average 2015-2024	Spent Last 10 years
Paving	\$ 504,684	\$ 823,904	\$ 744,971	\$ 71,309	\$ 1,001,500	\$ 723,709	\$ 845,187	\$ 900,000	\$ 1,000,000	\$ 856,798	\$ 749,397	\$ 7,493,965
Shoulder Stone / Grading	\$ 19,748	\$ 19,275	\$ 17,700	\$ -	\$ 1,900	\$ 5,408	\$ 17,605	\$ 20,000	\$ 20,000	\$ 8,304	\$ 10,304	
Crack Sealing / Crack Filling	\$ 60,600	\$ 195,607	\$ 63,000	\$ 75,143	\$ 75,495	\$ -	\$ 79,803	\$ 100,000	\$ 75,000	\$ 51,766	\$ 74,090	\$ 740,896
Restorative Seal / Preservative Seal	\$ 200,084	\$ 235,470	\$ 230,470	\$ 224,490	\$ 233,788	\$ 136,872	\$ 157,545	\$ 260,000	\$ 233,558	\$ 176,068	\$ 196,899	\$ 1,968,985
Pavement Markings	\$ 131,067	\$ 6,151	\$ 105,686	\$ 191,259	\$ 1,401	\$ 124,334	\$ 26,726	\$ 200,000	\$ 180,000	\$ 50,820	\$ 74,002	
Pothole Patching	\$ 123,636	\$ 95,974	\$ 50,710	\$ 41,953	\$ 147,789	\$ 118,207	\$ 55,840	\$ 130,000	\$ 130,000	\$ 107,278	\$ 90,719	\$ 907,194
Roadside Mowing/Trash Pickup	\$ 149,710	\$ 149,484	\$ 228,120	\$ 8,842	\$ 197,414	\$ 228,032	\$ 161,221	\$ 200,000	\$ 250,000	\$ 195,556	\$ 136,210	
Tree Trimming	\$ 49,252	\$ 23,825	\$ 16,870	\$ 3,925	\$ 11,036	\$ 31,934	\$ 31,125	\$ 55,000	\$ 60,000	\$ 24,698	\$ 26,633	
Snow Removal	\$ 216,579	\$ 252,611	\$ 249,478	\$ 381,953	\$ 339,583	\$ 353,789	\$ 327,699	\$ 450,000	\$ 450,000	\$ 340,357	\$ 265,126	
Signs	\$ 19,394	\$ 17,080	\$ 17,264	\$ 2,453	\$ 24,223	\$ 18,097	\$ 75,513	\$ 10,000	\$ 40,000	\$ 39,278	\$ 22,575	
Street Sweeping	\$ 19,000	\$ 49,700	\$ 71,324	\$ 32,700	\$ 98,100	\$ 68,300	\$ 115,545	\$ 90,000	\$ 110,000	\$ 93,982	\$ 55,564	
Emergency Response	\$ 1,500	\$ 8,525	\$ 3,450	\$ -	\$ -	\$ 20,000	\$ 2,292	\$ 20,000	\$ 20,000	\$ 7,431	\$ 5,795	
Roundabout/Intersection Maintenance	\$ 83,529	\$ 92,051	\$ 69,956	\$ 6,528	\$ 75,903	\$ 77,331	\$ 99,566	\$ 125,000	\$ 125,000	\$ 84,266	\$ 65,294	
Traffic Calming	\$ -	\$ -			\$ -	\$ 20,000	\$ 11,996	\$ 20,000	\$ 20,000	\$ 10,665	\$ 4,859	
Guardrail replacement curb repair	\$ 19,090	\$ 1,400			\$ -	\$ -	\$ 19,167	\$ 10,000	\$ 10,000	\$ 6,389	\$ 6,195	
	\$ -	\$ 14,575			\$ 2,213	\$ 148,859	\$ 10,137	\$ 30,000	\$ 25,000	\$ 53,736	\$ 27,395	
<b>TOTAL</b>	<b>\$1,597,873</b>	<b>\$1,985,634</b>	<b>\$1,868,999</b>	<b>\$1,040,555</b>	<b>\$ 2,210,343</b>	<b>\$2,074,871</b>	<b>\$2,036,967</b>	<b>\$2,620,000</b>	<b>\$2,748,558</b>	<b>\$ 2,107,393.70</b>	<b>\$ 1,811,055.06</b>	
% of budget pothole patching	8%	5%	3%	4%	7%	6%	3%	5%	5%	5%	5%	
Road Mileage	110.539	113.19	113.19	113.19	125.231	136.304	136.304	136.304	136.304	124.91	111.68	
\$ spent per mile	\$14,455.28	\$17,542.48	\$16,512.05	\$ 9,193.00	\$ 17,650.13	\$15,222.38	\$14,944.29	\$19,221.74	\$20,164.91	\$ 16,871.52	\$ 16,216.06	\$ 11,111,041
updated 9/05/2025			\$ 1,056,142	\$ 370,942	\$ 1,312,683	\$ 865,988	\$ 1,100,140	\$ 1,280,000	\$ 1,328,558	\$ 1,092,937	\$ 1,030,688	

TOWN OF AVON  
EXPENSE ACCOUNT SUMMARY  
2201 MVH FUNDS

Account Title Number	Appropriation Transfers	February 2026		Prev.Yr Per Prev.Yr YTD	Encumbered % Expended YTD	Uncommitted Unexpended
		Revisions Revised Appro	Per Expense YTD Expense			
2201.301.431.103	0.00	14,828.00	0.00	9,770.50	0.00	14,828.00
<b>MVH CONTRACTUAL SERVICE</b>	626,082.00	0.00	127,361.09	361,239.00	0.00	<b>434,990.89</b>
2201.301.431.109	100,000.00	726,082.00	291,091.11	447,009.08	40.09	434,990.89
MISC CONSULTING	45,000.00	0.00	0.00	12,825.00	0.00	45,000.00
2201.301.431.115	0.00	45,000.00	0.00	23,409.04	0.00	45,000.00
PUBLIC WORKS CONSULTING	250,000.00	0.00	23,574.55	37,631.95	0.00	211,039.54
2201.301.431.140	0.00	250,000.00	38,960.46	37,642.93	15.58	211,039.54
REPAIRS & MAINTENANCE	80,000.00	0.00	20,756.38	3,215.00	0.00	194.63
2201.301.435.101	0.00	80,000.00	79,805.37	33,725.73	99.76	194.63
PUBLIC WORKS UTILITIES	11,951.00	0.00	0.00	0.00	0.00	11,951.00
2201.301.438.101	0.00	11,951.00	0.00	0.00	0.00	11,951.00
GIS	37,500.00	0.00	1,052.20	749.00	0.00	35,139.28
2201.301.439.108	0.00	37,500.00	2,360.72	1,498.00	6.30	35,139.28
OTHER SERVICES & CHARGES	30,000.00	0.00	6,469.17	1,240.17	0.00	22,584.82
2201.301.439.110	0.00	30,000.00	7,415.18	10,335.03	24.72	22,584.82
LIABILITY INSURANCE / SUPPLIES	35,500.00	0.00	0.00	0.00	0.00	35,500.00
2201.301.439.203	0.00	35,500.00	0.00	0.00	0.00	35,500.00
IMPROV. OTHER THAN BUILDINGS	65,000.00	0.00	20,383.00	0.00	0.00	15,617.00
2201.301.443.101	0.00	65,000.00	49,383.00	0.00	75.97	15,617.00



---

To: Ryan Cannon, Town Manager; Steve Moore, Public Works Director  
Cc: Avon Town Council

From: Keeton Olson, Asset Manager

Date: March 3<sup>rd</sup>, 2026

Re: 2026 Roundabout Mowing

Avon Public Works contacted three landscaping contractors to provide a quote for roundabout mowing operations for the Town.

The contract includes completing twenty-four cycles of mowing of our 16 (soon to be 17) roundabouts and collection/disposal of all trash/debris before each mowing cycle, as well as routine landscaping maintenance. The project has 16 roadside miles (32 centerline); approximately 63 acres.

The Town's approved standard contract will be used for this project. Funding will be from MVH funds, as usual.

The two quotation totals we received were as follows:

1. All-Terrain Landscape and Snow Management - \$4,177.17/ cycle (\$100,252.24/ 1 year)
2. Wild Ridge Lawn and Landscape - \$4,200/ cycle (\$100,800.00/ 1 year)
3. Integrity Outdoor Solutions – No Quote

**We recommend that 'All-Terrain Landscape and Snow Maintenance' to be awarded the 2026 Roundabout Mowing Project in the amount of \$100,252.24 (or \$4,177.17 payment upon completion of each cycle).**

-The Request For Quotes is attached

If you have any further questions, please feel free to contact me at [kolson@avonindiana.gov](mailto:kolson@avonindiana.gov) or (317) 272-0948 ext. 129.



---

To: Interested Contractors

From: Keeton Olson, Asset Manager

Date: February 10<sup>th</sup>, 2026

Re: 2026 Roadside Mowing

Avon Public Works is receiving quotes for the following:

1. Contractor shall mow all right-of-way on Avon jurisdictional roads. Total mileage is approximately 45 centerline miles (90 roadside miles; 177 acres). Right-of-way will include roadside drainage swales, but exclude all protected native Indiana prairie areas; designated by 'DO NOT MOW OR SPRAY' signs (one pass, at least 42", on each side of the path will be required in these locations). If equipment cannot be used to mow the area of concern, the contractor will be expected to utilize weed eaters or other acceptable mowing equipment to maintain the area. Awarded contractor will weed eat around all structures in right-of-way excluding mailboxes. All curblines adjacent to mowing must be free of weeds, whether trimmed/sprayed or both. Seven monthly cycles of mowing are to be scheduled for each calendar year (May-November); contract may be extended by one year (up to three years consecutively) if mutually agreed upon. Contractor must be capable of satisfactorily mowing the entire area within the 10 day cycle timeframe, as well as any additional landscaping as needed. Contractor must own or lease at least 5 full commercial sized (zero-turn or comparable) mowers, 5 weed eaters, fertilizing/weed treatment equipment, suitable trimming equipment for larger foliage, and employ at least 5 employees to operate them. Contractor is to furnish a list of all employees, equipment, and materials they will utilize in their proposal.
2. Contractor shall collect and remove all trash and debris from all local roads before every mowing cycle. Contractor shall also provide separate pricing for road/roadside debris pickup on all jurisdictional roads, as well as US Hwy 36 from Old Main St to Raceway Rd. A price for deer/large animal pickup must also be provided.
3. Each cycle of debris pickup, trimming, and mowing shall be completed within 10 consecutive days, weather permitting, within the month that the cycle occurs.

**This project will be for a one-year contract**, extendable for up to three years. Submitted quotes must be a lump sum for the annual mowing contract, seven monthly cycles of mowing in 2026 and disposal of all material collected, with the amount for each cycle of mowing and each cycle of trash/debris removal listed for billing purposes. First mowing cycle is to be complete by Memorial Day weekend (the



---

weekend before the last Monday of May), third cycle complete for Independence Day (July 4<sup>th</sup>), fifth cycle to be complete for Labor Day (September 2<sup>nd</sup>), and last cycle to be complete before Winter. Hourly rates for on-call removal of large animals and on-call debris removal shall be provided. All quotes should be submitted no later than 12 pm on February 27<sup>th</sup>, 2026. See attached quotation example below.

If you have any further questions, please feel free to contact me at [kolson@avonindiana.gov](mailto:kolson@avonindiana.gov) or (317) 272-0948 ext. 129.



---

## Avon Roadside Mowing Project

### Quotation

#### Price per Cycle:

- |                                   |        |
|-----------------------------------|--------|
| 1. Mowing/trimming/trash removal- | \$X.XX |
| 2. Mowing/trimming/trash removal- | \$X.XX |
| 3. Mowing/trimming/trash removal- | \$X.XX |
| 4. Mowing/trimming/trash removal- | \$X.XX |
| 5. Mowing/trimming/trash removal- | \$X.XX |
| 6. Mowing/trimming/trash removal- | \$X.XX |
| 7. Mowing/trimming/trash removal- | \$X.XX |

Additional Services- \$X.XX

---

**Total:** **\$XX.XX**

Signed by \_\_\_\_\_ Signed by \_\_\_\_\_  
Contractor Town

# Avon 2026 Mowing Map

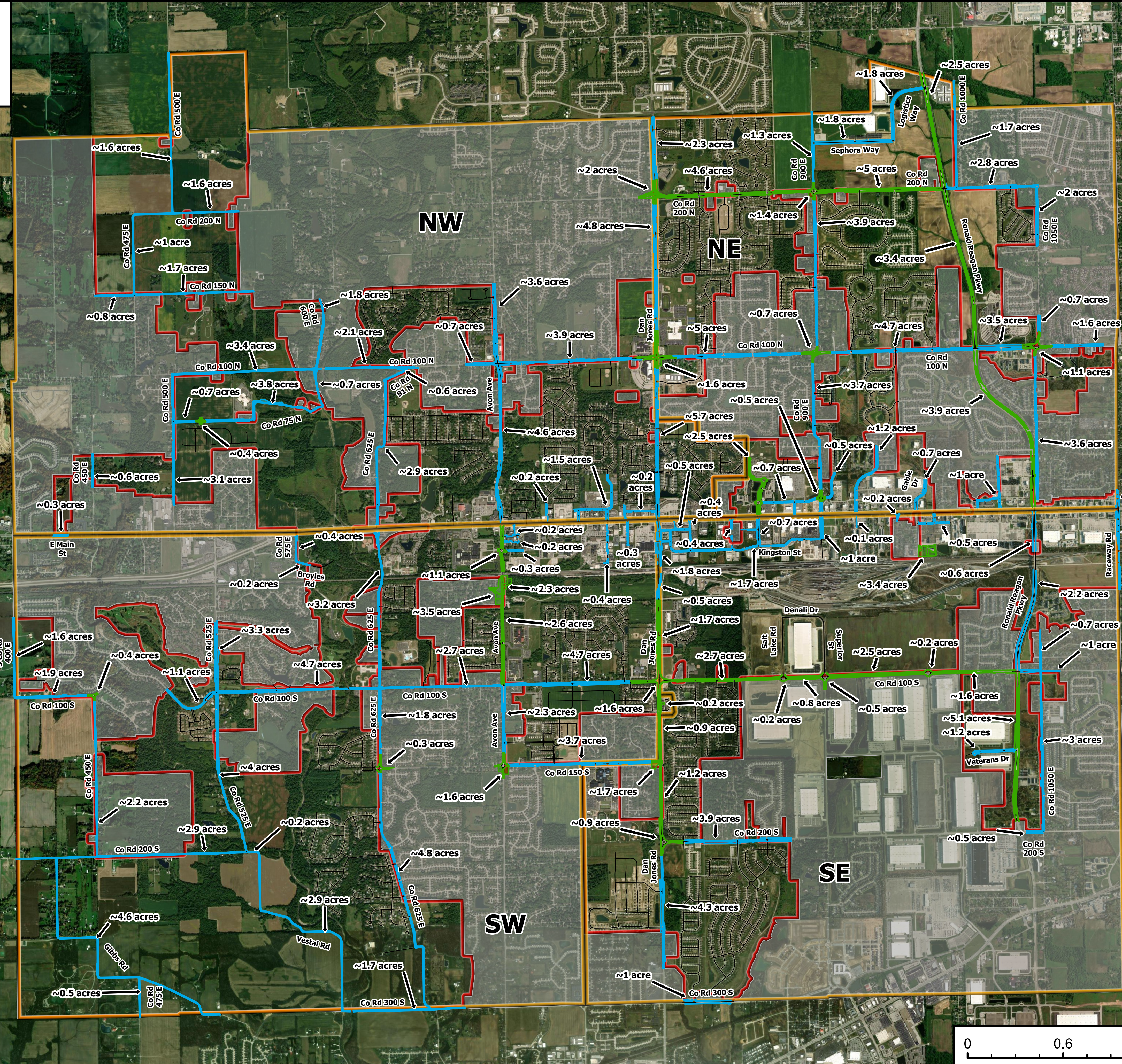
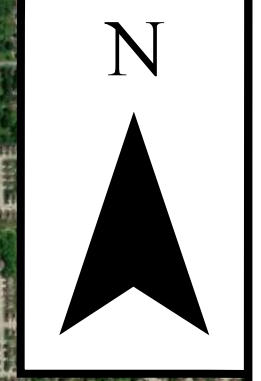

The total acreage to be mowed for the Roundabout Contract is approximately 65 acres, and the total acreage to be mowed for the ROW Contract is approximately 177 acres.

**Legend**

- ▭ ROW Contract
- ▭ Roundabout Contract
- ▭ Avon Corporate Boundary
- ▭ Washington Township
- Avon Streets
- ▭ Avon Quadrants

0 0.6 1.2 1.8 2.4 Miles



# Service Proposal

**TOWN OF AVON  
US HWY 36  
AVON, INDIANA 46123**

**Roundabout | Maintenance | 2026**  
Avon, Indiana 46123

**Est ID:** EST3563084 2026

**Date:** Feb-17-2026

Service Term: March 2026 - December 2026

<b>CONTRACT SERVICES</b>	<b>Visits</b>	<b>Billing Type</b>	<b>Visit Price</b>	<b>Season Price</b>
<b>Mowing</b>	<b>24</b>	<b>Per Season</b>	<b>\$3,319.04</b>	<b>\$79,656.96</b>

Mow all curbed ROW at/approaching the Town of Avon's 16 Roundabouts. Also includes mowing medians and curbed roadsides along Danjones Rd, 100 S, 200 N, and Ronald Regan PKWY, per map provided by town "Town of Avon 2026 Mowing Map". Trash to be picked up at each mowing cycle and disposed of.

<b>Bed Cut Out</b>	<b>1</b>	<b>Per Season</b>	<b>\$1,825.91</b>	<b>\$1,825.91</b>
--------------------	----------	-------------------	-------------------	-------------------

Cut out landscape beds and tree rings prior to mulch installation.

<b>Bed Maint.</b>	<b>7</b>	<b>Per Season</b>	<b>\$838.40</b>	<b>\$5,868.80</b>
-------------------	----------	-------------------	-----------------	-------------------

Spray Landscape Beds, Tree Rings, and Curbs For Weeds

<b>Fall Clean Up</b>	<b>1</b>	<b>Per Season</b>	<b>\$1,561.20</b>	<b>\$1,561.20</b>
----------------------	----------	-------------------	-------------------	-------------------

Cut down perennials and grasses after first hard freeze. Clean up beds of heavy leaf deposits

<b>Fertilizer Application Rnd 1</b>	<b>1</b>	<b>Per Season</b>	<b>\$3,002.46</b>	<b>\$3,002.46</b>
-------------------------------------	----------	-------------------	-------------------	-------------------

All Terrain Landscape and Snow Management  
136 Casco Drive  
Avon, Indiana  
46123

P.3173398536

allterrainlandscape.com  
info@allterrainlandscape.com

CONTRACT SERVICES	Visits	Billing Type	Visit Price	Season Price
-------------------	--------	--------------	-------------	--------------

Pre-emergent [Early Spring]

<b>Fertilizer Application Rnd 2</b>	<b>1</b>	<b>Per Season</b>	<b>\$3,569.46</b>	<b>\$3,569.46</b>
-------------------------------------	----------	-------------------	-------------------	-------------------

Liquid Broad Leaf Control w/ Granular Fertilizer [Late Spring]

<b>Fertilizer Application Rnd 3</b>	<b>1</b>	<b>Per Season</b>	<b>\$3,569.46</b>	<b>\$3,569.46</b>
-------------------------------------	----------	-------------------	-------------------	-------------------

Liquid Broad Leaf Control w/ Granular Fertilizer [Late Summer]

<b>Irrigation Start Up</b>	<b>1</b>	<b>Per Season</b>	<b>\$670.26</b>	<b>\$670.26</b>
----------------------------	----------	-------------------	-----------------	-----------------

Turn on irrigaiton systems. (200N/Danjones, 100N/Danjones, 100S/Danjones). Check and adjust heads. Preform backflow test and submit to proper water provider.

<b>Irrigation Shut Down</b>	<b>1</b>	<b>Per Season</b>	<b>\$527.73</b>	<b>\$527.73</b>
-----------------------------	----------	-------------------	-----------------	-----------------

Blow out irrigation systems to prevent winter freeze damage.

---

<b>SubTotal (All Contract Services)</b>	<b>\$100,252.24</b>
---	---------------------

<b>Taxes</b>	<b>\$0.00</b>
--------------	---------------

---

<b>Total (All Contract Services)</b>	<b>\$100,252.24</b>
--------------------------------------	---------------------

*The total price of all seasonal services is \$100,252.24 collected in 10 payments of \$10,025.22 per payment (\$10,025.22 after tax).*

Per Vist/Hourly Billing	Visits	Billing Type	Visit Price
-------------------------	--------	--------------	-------------

<b>Mulch Install</b>	<b>1</b>	<b>Per Visit</b>	<b>\$21,740.70</b>
----------------------	----------	------------------	--------------------

Apply Pre-emergent weed control prior to mulch installation.

Install roughly 300 yards of Brown dyed mulch into landscape beds and tree rings previously mulched.

Per Vist/Hourly Billing	Visits	Billing Type	Visit Price
<b>Additional Services -Labor/Hour</b>	<b>1</b>	<b>Per Hour/Unit</b>	
<b>Item Name</b>			<b>Rate Unit</b>
Landscape Install Crew			\$55.00 per Hours

**Payment Terms and Conditions**

All labor, materials, and equipment necessary to accomplish the above work quoted shall be provided for the landscape seasons from March 2026-December 2026, and shall be split into payments as mentioned above starting in March with the last payment in December.

- A service charge of 1.5% per month will be added to all balances not paid within 30 days of invoice. This represents and annual rate of 18%. In addition to all service charges, there shall also be paid the reasonable cost of collections, including attorneys' fee and court costs. Equal monthly installments do not necessarily reflect the costs of services preformed.
- A service charge of 3% will be charged to any credit card use for payment.
- It is the responsibility of the customer to make sure that delivery of payment to contractor has been received. Contractor will not be liable to pick payments up from customer.

**Fuel:** Due to All Terrain's significant fuel consumption in vehicles and equipment and the volatility of fuel prices, All Terrain reserves the right to add a fuel surcharge to protect against significant cost increases during the contractual period. Surcharges are based on % of the invoice and may apply if fuel is over \$4.00/gal.

Estimate authorized by:  Estimate approved by: \_\_\_\_\_  
 Craig Thompson

Signature Date: 02/17/2026 Signature Date: \_\_\_\_\_

Email: Info@Allterrainlandscape.com





Town Of Avon Department of Public Works:

Below is a summary of our mowing/turf care equipment and team member abilities.

- All Services will be performed in house, by trained/certified All Terrain Landscape team members. Our team is certified to apply chemicals (**category 3a,3b,5**) and test backflow devices (**3 licensed backflow testers on staff**) for irrigation systems.
- Our team is made up of (6) office staff, (2) account managers, (10) team leads, and (20) team labors. (proof of employment available upon request)
- Equipment consists of (28) commercial Mowers, (25) trimmers, (28) blowers, (6) chemical application machines, (19) trucks, (20) trailers, (3) skid steers, (1) loader, plus a bunch of misc. hand tools. (proof of equipment available upon request)

If you require any additional information, please let us know.

Thank you

A handwritten signature in black ink, appearing to read "Craig Thompson", written in a cursive style.

Craig Thompson

Owner/CEO

All Terrain Landscape and Snow Management





# Service Proposal

**TOWN OF AVON**  
**US HWY 36**  
**AVON, INDIANA 46123**

**Roundabouts | Spring Clean Up | 2026**  
Avon, Indiana 46123

**Est ID:** EST3579859 2026

**Date:** Feb-23-2026

---

Per Vist/Hourly Billing	Visits	Billing Type	Visit Price
Spring Clean Up	1	Per Visit	\$2,724.88

Cut down perennials and grasses that were not cut down in the fall for a fall clean up.

\*\*\*If awarded both roadside mowing and roundabout maintenance contracts, we will complete this service at no cost\*\*\*

**Payment Terms and Conditions**

All labor, materials, and equipment necessary to accomplish the above work quoted shall be provided for the landscape seasons from March 2026-December 2026, and shall be split into payments as mentioned above starting in March with the last payment in December.

- A service charge of 1.5% per month will be added to all balances not paid within 30 days of invoice. This represents an annual rate of 18%. In addition to all service charges, there shall also be paid the reasonable cost of collections, including attorneys' fee and court costs. Equal monthly installments do not necessarily reflect the costs of services performed.
- A service charge of 3% will be charged to any credit card use for payment.
- It is the responsibility of the customer to make sure that delivery of payment to contractor has been received. Contractor will not be liable to pick payments up from customer.

**Fuel:** Due to All Terrain's significant fuel consumption in vehicles and equipment and the volatility of fuel prices, All Terrain reserves the right to add a fuel surcharge to protect against significant cost increases during the contractual period. Surcharges are based on % of the invoice and may apply if fuel is over \$4.00/gal.

**Estimate authorized by:**   
\_\_\_\_\_

Craig Thompson

**Estimate approved by:** \_\_\_\_\_

**Signature Date:** \_\_\_\_\_

02/24/2026

**Signature Date:** \_\_\_\_\_

**Email:** Info@Allterrainlandscape.com

Public Works Maintenance Trends												
Activity	2018	2019	2020	2021	2022	2023	Actual 2024	Budget 2025	Budget 2026	Average 2022-2024	Average 2015-2024	Spent Last 10 years
Paving	\$ 504,684	\$ 823,904	\$ 744,971	\$ 71,309	\$ 1,001,500	\$ 723,709	\$ 845,187	\$ 900,000	\$ 1,000,000	\$ 856,798	\$ 749,397	\$ 7,493,965
Shoulder Stone / Grading	\$ 19,748	\$ 19,275	\$ 17,700	\$ -	\$ 1,900	\$ 5,408	\$ 17,605	\$ 20,000	\$ 20,000	\$ 8,304	\$ 10,304	
Crack Sealing / Crack Filling	\$ 60,600	\$ 195,607	\$ 63,000	\$ 75,143	\$ 75,495	\$ -	\$ 79,803	\$ 100,000	\$ 75,000	\$ 51,766	\$ 74,090	\$ 740,896
Restorative Seal / Preservative Seal	\$ 200,084	\$ 235,470	\$ 230,470	\$ 224,490	\$ 233,788	\$ 136,872	\$ 157,545	\$ 260,000	\$ 233,558	\$ 176,068	\$ 196,899	\$ 1,968,985
Pavement Markings	\$ 131,067	\$ 6,151	\$ 105,686	\$ 191,259	\$ 1,401	\$ 124,334	\$ 26,726	\$ 200,000	\$ 180,000	\$ 50,820	\$ 74,002	
Pothole Patching	\$ 123,636	\$ 95,974	\$ 50,710	\$ 41,953	\$ 147,789	\$ 118,207	\$ 55,840	\$ 130,000	\$ 130,000	\$ 107,278	\$ 90,719	\$ 907,194
Roadside Mowing/Trash Pickup	\$ 149,710	\$ 149,484	\$ 228,120	\$ 8,842	\$ 197,414	\$ 228,032	\$ 161,221	\$ 200,000	\$ 250,000	\$ 195,556	\$ 136,210	
Tree Trimming	\$ 49,252	\$ 23,825	\$ 16,870	\$ 3,925	\$ 11,036	\$ 31,934	\$ 31,125	\$ 55,000	\$ 60,000	\$ 24,698	\$ 26,633	
Snow Removal	\$ 216,579	\$ 252,611	\$ 249,478	\$ 381,953	\$ 339,583	\$ 353,789	\$ 327,699	\$ 450,000	\$ 450,000	\$ 340,357	\$ 265,126	
Signs	\$ 19,394	\$ 17,080	\$ 17,264	\$ 2,453	\$ 24,223	\$ 18,097	\$ 75,513	\$ 10,000	\$ 40,000	\$ 39,278	\$ 22,575	
Street Sweeping	\$ 19,000	\$ 49,700	\$ 71,324	\$ 32,700	\$ 98,100	\$ 68,300	\$ 115,545	\$ 90,000	\$ 110,000	\$ 93,982	\$ 55,564	
Emergency Response	\$ 1,500	\$ 8,525	\$ 3,450	\$ -	\$ -	\$ 20,000	\$ 2,292	\$ 20,000	\$ 20,000	\$ 7,431	\$ 5,795	
Roundabout/Intersection Maintenance	\$ 83,529	\$ 92,051	\$ 69,956	\$ 6,528	\$ 75,903	\$ 77,331	\$ 99,566	\$ 125,000	\$ 125,000	\$ 84,266	\$ 65,294	
Traffic Calming	\$ -	\$ -			\$ -	\$ 20,000	\$ 11,996	\$ 20,000	\$ 20,000	\$ 10,665	\$ 4,859	
Guardrail replacement	\$ 19,090	\$ 1,400			\$ -	\$ -	\$ 19,167	\$ 10,000	\$ 10,000	\$ 6,389	\$ 6,195	
curb repair	\$ -	\$ 14,575			\$ 2,213	\$ 148,859	\$ 10,137	\$ 30,000	\$ 25,000	\$ 53,736	\$ 27,395	
<b>TOTAL</b>	<b>\$1,597,873</b>	<b>\$1,985,634</b>	<b>\$1,868,999</b>	<b>\$1,040,555</b>	<b>\$ 2,210,343</b>	<b>\$2,074,871</b>	<b>\$2,036,967</b>	<b>\$2,620,000</b>	<b>\$2,748,558</b>	<b>\$ 2,107,393.70</b>	<b>\$ 1,811,055.06</b>	
% of budget pothole patching	8%	5%	3%	4%	7%	6%	3%	5%	5%	5%	5%	
Road Mileage	110.539	113.19	113.19	113.19	125.231	136.304	136.304	136.304	136.304	124.91	111.68	
\$ spent per mile	\$14,455.28	\$17,542.48	\$16,512.05	\$ 9,193.00	\$ 17,650.13	\$15,222.38	\$14,944.29	\$19,221.74	\$20,164.91	\$ 16,871.52	\$ 16,216.06	\$ 11,111,041
updated 9/05/2025			\$ 1,056,142	\$ 370,942	\$ 1,312,683	\$ 865,988	\$ 1,100,140	\$ 1,280,000	\$ 1,328,558	\$ 1,092,937	\$ 1,030,688	

TOWN OF AVON  
EXPENSE ACCOUNT SUMMARY  
2201 MVH FUNDS

Account Title Number	Appropriation Transfers	February 2026		Prev.Yr Per Prev.Yr YTD	Encumbered % Expended YTD	Uncommitted Unexpended
		Revisions Revised Appro	Per Expense YTD Expense			
2201.301.431.103	0.00	14,828.00	0.00	9,770.50	0.00	14,828.00
<b>MVH CONTRACTUAL SERVICE</b>	626,082.00	0.00	127,361.09	361,239.00	0.00	<b>434,990.89</b>
2201.301.431.109	100,000.00	726,082.00	291,091.11	447,009.08	40.09	434,990.89
MISC CONSULTING	45,000.00	0.00	0.00	12,825.00	0.00	45,000.00
2201.301.431.115	0.00	45,000.00	0.00	23,409.04	0.00	45,000.00
PUBLIC WORKS CONSULTING	250,000.00	0.00	23,574.55	37,631.95	0.00	211,039.54
2201.301.431.140	0.00	250,000.00	38,960.46	37,642.93	15.58	211,039.54
REPAIRS & MAINTENANCE	80,000.00	0.00	20,756.38	3,215.00	0.00	194.63
2201.301.435.101	0.00	80,000.00	79,805.37	33,725.73	99.76	194.63
PUBLIC WORKS UTILITIES	11,951.00	0.00	0.00	0.00	0.00	11,951.00
2201.301.438.101	0.00	11,951.00	0.00	0.00	0.00	11,951.00
GIS	37,500.00	0.00	1,052.20	749.00	0.00	35,139.28
2201.301.439.108	0.00	37,500.00	2,360.72	1,498.00	6.30	35,139.28
OTHER SERVICES & CHARGES	30,000.00	0.00	6,469.17	1,240.17	0.00	22,584.82
2201.301.439.110	0.00	30,000.00	7,415.18	10,335.03	24.72	22,584.82
LIABILITY INSURANCE / SUPPLIES	35,500.00	0.00	0.00	0.00	0.00	35,500.00
2201.301.439.203	0.00	35,500.00	0.00	0.00	0.00	35,500.00
IMPROV. OTHER THAN BUILDINGS	65,000.00	0.00	20,383.00	0.00	0.00	15,617.00
2201.301.443.101	0.00	65,000.00	49,383.00	0.00	75.97	15,617.00



---

To: Ryan Cannon, Town Manager; Steve Moore, Public Works Director  
Cc: Avon Town Council

From: Keeton Olson, Asset Manager

Date: March 4<sup>th</sup>, 2026

Re: 2026 Sidewalk and Drainage Project-Harvest Landing

Avon Public Works contacted four capable contractors to provide a quote for replacing sidewalk and installing drainage.

The project includes replacing ten curb ramps to make them ADA compliant, replacing multiple non-compliant residential sidewalks, installing new sidewalks in the Zaxby's/Harvest Landing/Dr. Charles Nelson area; to complete sidewalk segments and associated drainage work will be completed as well.

Funding will be taken partially from the Concrete/Sidewalk budget line, and the Stormwater budget for drainage work.

The two quotation totals we received were as follows:

1. Holz knecht Outdoor Enterprises - \$75,285.00
2. Concrete Evolutions – \$43,755.00
3. Earl Mink– No Quote
4. Flex Excavating– No Quote

**We recommend that 'Concrete Evolutions' to be awarded this 2026 Sidewalk and Drainage Project in the amount of \$43,755.00.**

-The Request For Quotes is attached

If you have any further questions, please feel free to contact me at [kolson@avonindiana.gov](mailto:kolson@avonindiana.gov) or (317) 272-0948 ext. 129.

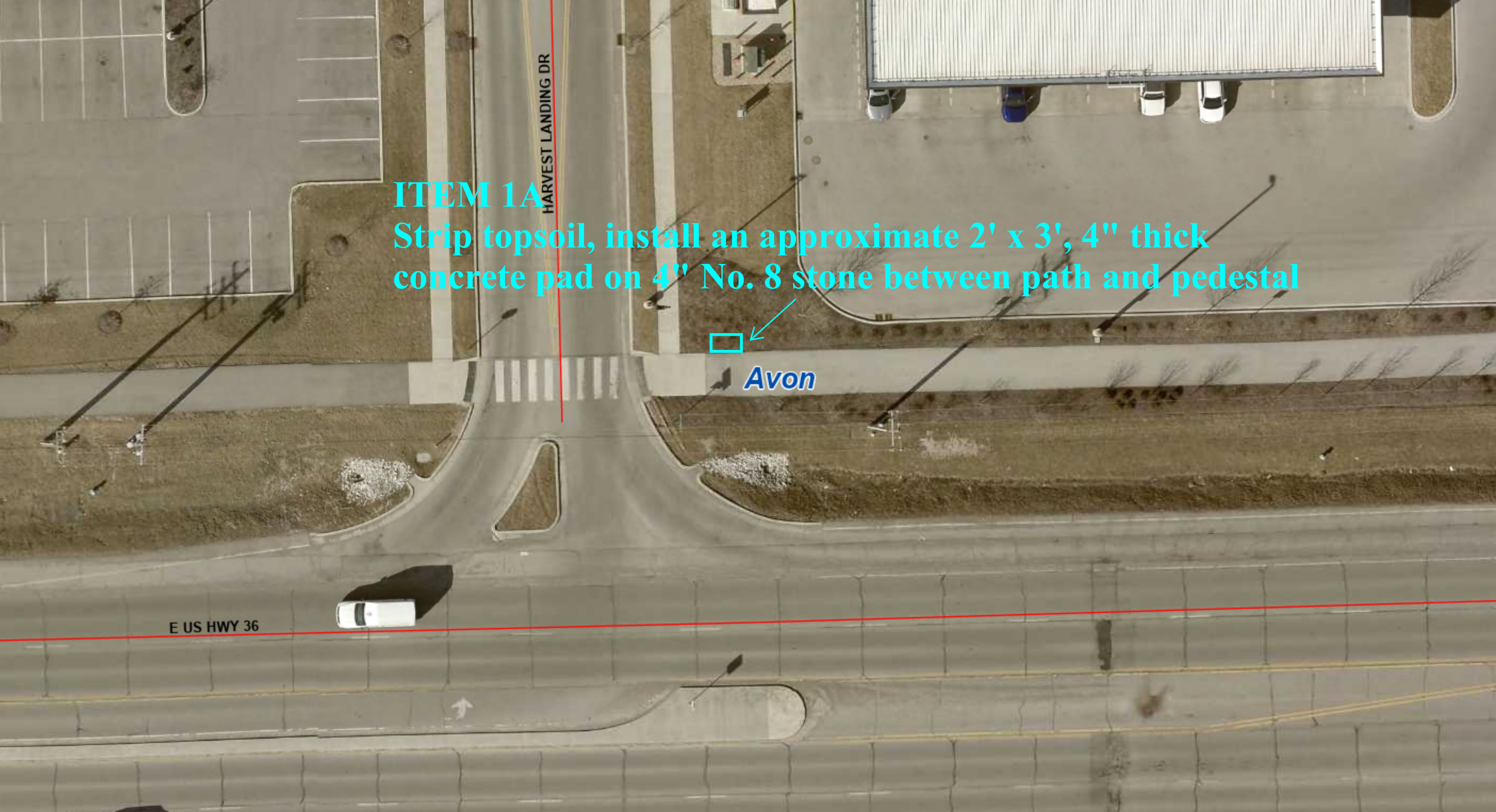

HARVEST LANDING DR

**ITEM 1A**  
Strip topsoil, install an approximate 2' x 3', 4" thick concrete pad on 4" No. 8 stone between path and pedestal



Avon

E US HWY 36

## ITEM 1B

Remove obstructions, strip topsoil, bring to grade with 4" compacted 53's, and install ADA sidewalk to connect existing paths

Avon

DR. CHARLES NELSON DR

## ITEM 1C

Remove 2 sidewalk panels, strip topsoil, install 4" of 53's to grade with a 45 degree angle shift to avoid utilities, and replace curb ramp

**ITEM 1D**  
Install new ADA sidewalk to connect paths

Avon

**ITEM 2**  
Install 20 LF of 12" HDPE pipe (4" No. 8 or No. 53 stone bedding and encasement).  
Fill to grade w/No. 8 or No. 53 stone. Metal end sections, and fabric/rip-rap around ends.

E US HWY 36

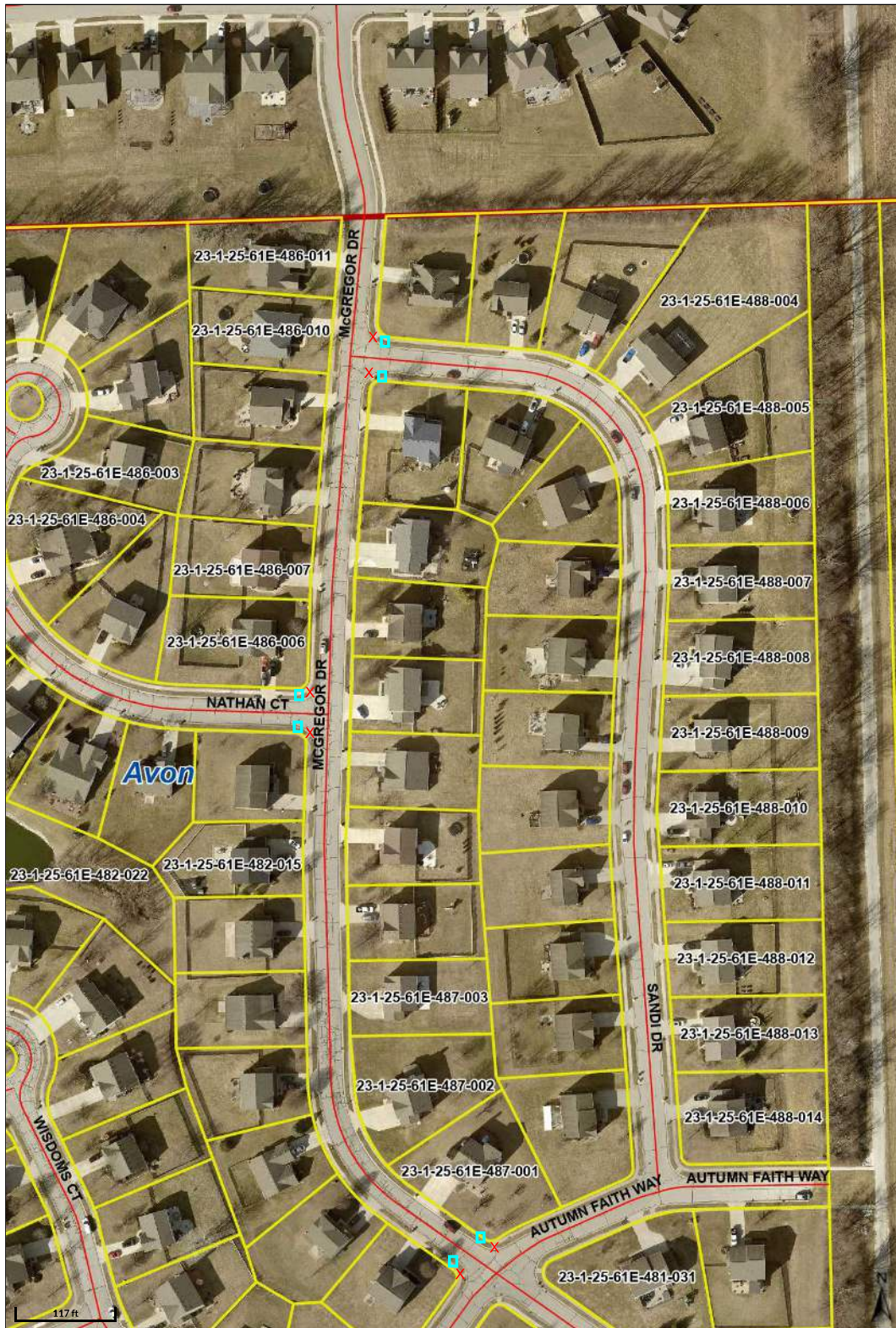

**Overview**



**Legend**

- Roads 911
- Parcels
- Zoning Ordinances
- Corporate Boundary

Date created: 1/8/2026  
 Last Data Uploaded: 1/8/2026 9:45:00 AM

Developed by  **SCHNEIDER**  
REGISTRAR

**REPLACE 52 5' X 5' SIDEWALK PANELS**  
**REMOVE 6 CURB RAMPS**  
**REMOVE CURB FOR NEW CURB RAMPS**  
**INSTALL NEW CURB AND 6 RAMPS**



Keeton Olson  
 To: Steve Moore; Betsy Porter; Elijah Scott

Bcc: Earl Mink <earlmink@gmail.com>; Earl Mink <minkeexcavating@gmail.com>; thobknecht68 <thobknecht68@gmail.com>; flex.excavating@yahoo.com; Flex.excavating@yahoo.com



2 attachments (5 MB) Save all to OneDrive - Avon Download all

Gentlemen,

The Town of Avon is accepting quotes for a sidewalk project, view the attached information and return your quote by 12 P.M. on Friday 1/16/26 to be considered. The quote will need to be split into parts, items.

ITEMS:

1 A/B/C: 1 LSUM = \$ \_\_\_\_\_  
 2: 1 LSUM = \$ \_\_\_\_\_

McGregor Road is unit prices:

3A sidewalk removal (includes ramps, but not curb through ramps) 175 SYS x unit price \$ \_\_\_\_\_ = \$ \_\_\_\_\_  
 3B is curb removal (includes curb through ramps) 100 LFT x unit price \$ \_\_\_\_\_ = \$ \_\_\_\_\_  
 3C PCC Sidewalk, 4 INCH = 153 SYS x unit price \$ \_\_\_\_\_ = \$ \_\_\_\_\_  
 3D Concrete Curb and Gutter (includes curb through ramps) 100 LFT x unit price \$ \_\_\_\_\_ = \$ \_\_\_\_\_  
 3E Curb Ramp (includes 4" stone base, truncated domes.  
 Does NOT include curb through ramp). 60 SYS x unit price \$ \_\_\_\_\_ = \$ \_\_\_\_\_

McGregor Road TOTAL: \$ \_\_\_\_\_

Grand TOTAL: \$ \_\_\_\_\_

Please call my cell if you have any questions: (317)416-9091.

Thank you,

Keeton Olson  
 Asset Manager  
 Town of Avon  
 6570 East US Highway 36  
 Avon, IN 46123  
 317-272-0948 X 129  
*Over \$100 Million for Roads & Trails in Avon*



Please note, this email is public record.

ITEMS: 1 A. \$600  
1 B. \$2,200  
1 A/B/C: 1 C. \$2,300  
1 D. \$3,840

1

LSUM = \$ 8,940

2: ITEM 2 - HDPE PIPE = \$2,980

1 LSUM = \$ 2,980

McGregor Road is unit prices:

3A sidewalk removal (includes ramps, but not curb through ramps) 175 SYS x unit price  
\$ 27 = \$ 4,725.<sup>00</sup>

3B is curb removal (includes curb through ramps)  
100 LFT x unit price  
\$ 10 = \$ 1,000

3C PCC Sidewalk, 4 INCH =

153

SYS x unit price \$ 70 =

\$ 10,710

3D Concrete Curb and Gutter (includes curb through ramps) 100 LFT x unit price

\$ 40 = \$ 4,000

3E Curb Ramp (includes 4" stone base, truncated domes.

Does NOT include curb through ramp).

60 SYS x

unit price \$ 190 =

\$ 11,400

-includes 80 soft domes

-540 soft ramps

McGregor Road TOTAL:

\$ 31,835

Grand TOTAL: \$43,755

Concrete  
Evolution S

				GEN FUND	Road Bond	2024 Road	CCD	CCI	LRS	MVH	MVH Restrict	Riverboat	Storm	Wheel Tax	Edit	Infrastructure Contrib	HRH TIF	TIF	TOTAL		
<b>Debt</b>																					
	Road Bond Payments	270,000	500,000		265,000	235,000														500,000	\$ -
	Edit Bond Payment	289,238	293,263												293,263					293,263	\$ -
	TIF Bond Payments- lease rental payments	2,608,213	2,509,143																2,509,143	2,509,143	\$ -
	<b>Sub-total</b>	<b>\$ 3,167,451</b>	<b>\$ 3,302,406</b>	<b>\$ -</b>	<b>\$ 265,000</b>	<b>\$ 235,000</b>	<b>\$ -</b>	<b>\$ -</b>	<b>\$ -</b>	<b>\$ -</b>	<b>\$ -</b>	<b>\$ -</b>	<b>\$ -</b>	<b>\$ -</b>	<b>\$ 293,263</b>	<b>\$ -</b>	<b>\$ -</b>	<b>\$ 2,509,143</b>	<b>\$ 3,302,406</b>	<b>\$ -</b>	
<b>Capital</b>																					
	Raceway Rd/CR 100 N Rdbt - PE CN	1,400,000																		0	\$ -
	School Flashing Beacon's - Middle West 2025	70,000	-																	0	\$ -
	ADA Sidewalk and ramp repair	50,000	50,000							50,000										50,000	\$ -
	Town Vehicle replacement program	120,000	60,000				60,000													60,000	\$ -
	Police Vehicles and technology	443,000	458,000				408,000								50,000					458,000	\$ -
	School Technology(security or 1 to 1)	100,000	100,000															100,000		100,000	\$ -
	Avon Village Parkway Safety Improvement	153,049	175,000							175,000										175,000	\$ -
	Street Lights - MISC	10,000	15,000							15,000										15,000	\$ -
	Paving - TIF District	200,000	200,000																200,000	200,000	\$ -
	Intersection Improvement (36/525E and 525/Main	300,000	210,000																210,000	210,000	\$ -
	SBRT lane - CR 500 E and Main St	15,000	75,000														75,000			75,000	\$ -
	Intersection Improvement (500 E and 100 N)	75,000	-																	0	\$ -
	Dan Jones Widening - 100 S to 150 S	141,787																		0	\$ -
	Dan Jones Widening - US 36 to CR 100 N	300,000	3,155,857				600,000							200,000	250,000				2,105,857	3,155,857	\$ -
	Preliminary Design DJ Rd - 150 S-200S (Ph IV)	150,000	250,000														225,000		25,000	250,000	\$ -
	Dan Jones Bridge - beautification	750,000	750,000																750,000	750,000	\$ -
	CR 900 E improvements and Rdbt	1,780,000																		0	\$ -
	Emergency Preemption	80,000	82,151							82,151										82,151	\$ -
	Signal Safety Enhancements	50,000	50,000							50,000										50,000	\$ -
	Police Station - additional remodel		175,000															175,000		175,000	\$ -
	Police Training and PW Facility - design		325,000															325,000		325,000	\$ -
	Road Side Drainage	50,000	50,000											50,000						50,000	\$ -
	Easement Acquisition	25,000	25,000											25,000						25,000	\$ -
	Stormwater Capital Improvements	187,565	255,837											255,837						255,837	\$ -
	<b>Sub-total</b>	<b>\$ 6,450,401</b>	<b>\$ 6,461,845</b>	<b>\$ -</b>	<b>\$ -</b>	<b>\$ -</b>	<b>\$ 1,068,000</b>	<b>\$ -</b>	<b>\$ -</b>	<b>\$ 372,151</b>	<b>\$ -</b>	<b>\$ -</b>	<b>\$ 330,837</b>	<b>\$ 200,000</b>	<b>\$ 300,000</b>	<b>\$ 300,000</b>	<b>\$ 500,000</b>	<b>\$ 3,390,857</b>	<b>\$ 6,461,845</b>	<b>\$ -</b>	
	<b>TOTAL</b>	<b>14,048,013</b>	<b>14,590,788</b>	<b>127,049</b>	<b>265,000</b>	<b>235,000</b>	<b>1,500,000</b>	<b>30,250</b>	<b>600,000</b>	<b>1,810,000</b>	<b>490,000</b>	<b>100,000</b>	<b>1,325,000</b>	<b>400,000</b>	<b>908,489</b>	<b>300,000</b>	<b>500,000</b>	<b>6,000,000</b>	<b>14,590,788</b>	<b>0</b>	
				0	0	0	0	0	0	0	0	0	0	0	0	0	0	0	0	0	
<b>Unfunded CIP</b>																					
	Road Impact Fee Study																				
	Street Lights - Nbhds																				
	Harvest Ridge - Ded Left - PE																				
	Thomridge - Ded left - PE																				
	Pines West - Ded left - PE																				
	RRP - IU West Entrance - right turn ln																				

TOWN OF AVON  
EXPENSE ACCOUNT SUMMARY  
2201 MVH FUNDS

Account Title Number	Appropriation Transfers	February 2026		Prev.Yr Per Prev.Yr YTD	Encumbered % Expended YTD	Uncommitted Unexpended
		Revisions Revised Appro	Per Expense YTD Expense			
2201.301.431.103	0.00	14,828.00	0.00	9,770.50	0.00	14,828.00
<b>MVH CONTRACTUAL SERVICE</b>	626,082.00	0.00	127,361.09	361,239.00	0.00	<b>434,990.89</b>
2201.301.431.109	100,000.00	726,082.00	291,091.11	447,009.08	40.09	434,990.89
MISC CONSULTING	45,000.00	0.00	0.00	12,825.00	0.00	45,000.00
2201.301.431.115	0.00	45,000.00	0.00	23,409.04	0.00	45,000.00
PUBLIC WORKS CONSULTING	250,000.00	0.00	23,574.55	37,631.95	0.00	211,039.54
2201.301.431.140	0.00	250,000.00	38,960.46	37,642.93	15.58	211,039.54
REPAIRS & MAINTENANCE	80,000.00	0.00	20,756.38	3,215.00	0.00	194.63
2201.301.435.101	0.00	80,000.00	79,805.37	33,725.73	99.76	194.63
PUBLIC WORKS UTILITIES	11,951.00	0.00	0.00	0.00	0.00	11,951.00
2201.301.438.101	0.00	11,951.00	0.00	0.00	0.00	11,951.00
GIS	37,500.00	0.00	1,052.20	749.00	0.00	35,139.28
2201.301.439.108	0.00	37,500.00	2,360.72	1,498.00	6.30	35,139.28
OTHER SERVICES & CHARGES	30,000.00	0.00	6,469.17	1,240.17	0.00	22,584.82
2201.301.439.110	0.00	30,000.00	7,415.18	10,335.03	24.72	22,584.82
LIABILITY INSURANCE / SUPPLIES	35,500.00	0.00	0.00	0.00	0.00	35,500.00
2201.301.439.203	0.00	35,500.00	0.00	0.00	0.00	35,500.00
IMPROV. OTHER THAN BUILDINGS	65,000.00	0.00	20,383.00	0.00	0.00	15,617.00
2201.301.443.101	0.00	65,000.00	49,383.00	0.00	75.97	15,617.00



## **IWORQ SERVICE AGREEMENT**

### **For iWorQ applications and services**

Town of Avon, IN here after known as (“Customer”), enters into THIS SERVICE AGREEMENT (“Agreement”) with iWorQ Systems Inc. (“iWorQ”) with its principal place of business 1125 West 400 North, Suite 102, Logan, Utah 84321.

#### **1. SOFTWARE AS A SERVICE (SaaS) TERMS OF ACCESS:**

iWorQ grants Customer a non-exclusive, non-transferable limited access to use iWorQ service(s), application(s) on iWorQ’s authorized website for the fee(s) and terms listed in Appendix A. This agreement will govern all application(s) and service(s) listed in the Appendix A.

#### **2. CUSTOMER RESPONSIBILITY:**

Customer acknowledges that they are receiving only a limited subscription to use the application(s), service(s), and related documentation, if any, and shall obtain no titles, ownership nor any rights in or to the application(s), service(s), and related documentation, all of which title and rights shall remain with iWorQ. Customer shall not permit any user to reproduce, copy, or reverse engineer any of the application(s), service(s) and related documentation. iWorQ is not responsible for the content entered into iWorQ's database or uploaded as a document or image.

#### **3. TRAINING AND IMPLEMENTATION:**

Customer agrees to provide the time, resources, and personnel to implement iWorQ’s service(s) and application(s). iWorQ will assign a senior account manager and an account management team to implement service(s) and application(s). Typical implementation will take less than 60 days. iWorQ account managers will call twice per week, provide remote training once per week, and send weekly summary emails to the customer implementation team. iWorQ can provide project management and implementation documents upon request.

iWorQ will do ONE import of the Customer’s data. This import consists of importing data, sent by the Customer, in an electronic relational database format. Acquisition of data is the responsibility of the client; iWorQ will not be involved in negotiation for data with third parties.

Customer must have clear ownership of all forms, letters, inspections, checklists, and data sent to iWorQ.



#### **4. CUSTOMER DATA:**

Customer data will be stored in AWS GovCloud. iWorQ will use commercially reasonable efforts to backup, store and manage customer data. iWorQ does backups twice per week and onsite backups twice per week. Customer can run reports and export data from iWorQ application(s) at any time.

Customer can pay iWorQ for additional data management services(s), onsite backups application(s) and other service(s).

Data upload and usage is provided to every customer. This includes uploading files up to 25MB and 100GB of managed data usage on AWS GovCloud. Additional upload file sizes and managed data usage sizes can be provided based on the application(s) and service(s) listed in Appendix A.

Customers can upload and store images with personal information like driver's license, and more. This data can be used by the customer to complete the permitting, licensing, or code enforcement processes. Customer understands that the data must be uploaded and stored in the sensitive data upload section of the iWorQ software for access and security purposes.

iWorQ is not responsible for: (1) For the content entered into iWorQ's database, (2) For images or documents scanned locally and uploaded by the iWorQ users, (3) For documents or images uploaded by citizen over the web, and (4) For data sent to the Customer by iWorQ.

#### **5. CUSTOMER SUPPORT:**

Customer support and training are FREE and available Monday-Friday, from 6:00 A.M. to 5:00 P.M. MST, for any authorized user with a login. iWorQ provides unlimited remote Customer training (through webinars), phone support, help files, and documentation. Basic support requests are typically handled the same day. iWorQ provides "Service NOT Software".

#### **6. BILLING:**

iWorQ will invoice Customer on an annual basis. iWorQ will send invoices by mail and by email to the address(s) listed in Appendix A. Terms of the invoice are net 30 days from the date of the invoice. Any billing changes will require that a new Service(s) Agreement be signed by the Customer.

Any additional costs imposed by the Customer including business licenses, fees, or taxes will be added to the Customer's invoice yearly. Support and services fees may increase in subsequent years but will increase no more than 5% per year.



Customer pricing is based on a 3 Year Term and reflects a discounted annual price. Changes to the Term or the Termination Policy (Section 7. Termination:), will affect the annual pricing and could double your annual cost. Customer reserves the right to pay the 3 Year Term upfront to secure discounted annual pricing

## **7. TERMINATION:**

Either party may terminate this agreement after the initial 3-Year Term, without cause if the terminating party gives the other party sixty (60) days written notice. Should the Customer terminate any part of the application(s) and or service(s) the remaining balance will immediately become due. Should the Customer terminate any part of the application(s) and or service(s) a new Service(s) Agreement will need to be signed. Upon expiration of the Initial Term, this Agreement shall automatically be renewed for successive one (1) year terms unless either party provides notice of termination or non-renewal no less than sixty (60) days prior to expiration of the then-current term.

Upon termination of this Agreement, iWorQ will discontinue all application(s) and or service(s); iWorQ will provide customer with an electronic copy of all of Customer's data, if requested by the Customer (within 3-5 business days).

During the term of the Agreement, the Customer may request a copy of all of Customer's data, which shall be provided to Customer for a cost of no more than \$2500 per copy. Please note, if the Customer is not in compliance with the material terms and conditions of this Agreement, iWorQ will not be required to provide Customer with the data.

## **8. ACCEPTABLE USE:**

Customer represents and warrants that the application(s) and service(s) will only be used for lawful purposes, in a manner allowed by law, and in accordance with reasonable operating rules, and policies, terms and procedures. iWorQ may restrict access to users upon misuse of application(s) and service(s).

## **9. MISCELLANEOUS PROVISIONS:**

This Agreement will be governed by and construed in accordance with the laws of the State of Utah. Customer recognizes that iWorQ Systems is a software company located in Utah. Any changes to this section, including changes to the Venue or Forum, will be subject to an increase in their annual pricing.



**10. CUSTOMER IMPLEMENTATION INFORMATION:**

**Primary Implementation Contact** \_\_\_\_\_ Title \_\_\_\_\_

Office Phone \_\_\_\_\_ Cell (required) \_\_\_\_\_

Email \_\_\_\_\_

**Secondary Implementation Contact** \_\_\_\_\_ Title \_\_\_\_\_

Office Phone \_\_\_\_\_ Cell (required) \_\_\_\_\_

Email \_\_\_\_\_

**Portal Setup Contact** (if applicable) \_\_\_\_\_ Title \_\_\_\_\_

Office Phone \_\_\_\_\_ Cell \_\_\_\_\_

Email \_\_\_\_\_ Signature \_\_\_\_\_

(This person is responsible for placing the iWorQ Portal Link being placed on the agency's website within 90 days of the agreement signature. The iWorQ Portal Link will remain on agencies website for the entire Term of the agreement. If the iWorQ Portal Link is not placed on the city website within 90 days, the Agency agrees to pay an additional \$1,000 dollars towards setup costs (this is to cover iWorQ's time).

**11. CUSTOMER BILLING INFORMATION:**

Billing Contact \_\_\_\_\_ Title \_\_\_\_\_

Billing Address: \_\_\_\_\_

Office Phone \_\_\_\_\_ Cell \_\_\_\_\_

Email \_\_\_\_\_

PO# \_\_\_\_\_ Tax Exempt ID # (required) \_\_\_\_\_

NOTE: If a tax-exempt number is not provided, a 10% service increase will be added to the yearly invoice.

**12. ACCEPTANCE:**

The effective date of this Agreement is listed below. Authorized representatives of Customer and iWorQ have read the Agreement and agree and accept all the terms.

Signature \_\_\_\_\_ Effective Date: \_\_\_\_\_

Printed Name \_\_\_\_\_ Title \_\_\_\_\_ Office

Number \_\_\_\_\_ Cell Number \_\_\_\_\_



# **iWorQ Service(s) Agreement**

## **APPENDIX A**



## **iWorQ Price Proposal**

<b>Town of Avon, IN</b>	<b>Population- 15971</b>
6570 E US Highway 36, Avon, IN 46123	Prepared by: Joe Johnsen

### **Annual Subscription Fees**

<u><b>Application(s) and Service(s)</b></u>	<u><b>Package Price</b></u>	<u><b>Billing</b></u>
Community Development (Basic)  *Permit Management *Code Enforcement  -Available on any computer, tablet, or mobile device using Chrome Browser -Track permits and cases with customizable reporting -Track fees and payments -Inspection and plan review tracking -Track violations, activities and follow ups -Includes Sensitive File Uploads that are required to finish permit, licensing or code enforcement process (i.e Driver's License) -OpenStreetMap tracking abilities with quarterly updates -Free forms, letters, and/or permits utilizing iWorQ's template library, and up to 3 custom letters	<del>\$6,250.00</del> \$4,250.00	Annual
Payment Processing  - Online Credit/debit card processing (Through PayRoc) - Payments are recorded and tracked in iWorQ -iWorQ's reporting tool can track all historical transactions	\$1,000.00	Annual
Planning and Zoning - Enterprise Package  Package Includes: *Planning and Zoning Module *Online Portal *Online credit/debit card processing integrated with iWorQ (through PayRoc)  -Configurable portal for ease of applying and submitting applications, tracking current projects, and paying fees online -Includes access to 24 standard database driven web form templates and 3 custom database web forms for Portal Home - Available on any computer, tablet, or mobile device using Chrome Browser	<del>\$7,500.00</del> \$6,500.00	Annual



<ul style="list-style-type: none"> <li>- Track Projects, Contacts, Plan reviews, and Inspections</li> <li>- Track Fees and Payments</li> <li>- Built in workflow capabilities</li> <li>- Plan and schedule Meetings</li> <li>- Draw &amp; annotate on plans</li> <li>- Save data in layers on plans</li> <li>- Place watermarks on plans</li> <li>- Includes Sensitive File Uploads that are required to finish projects (i.e Driver's License)</li> <li>- Configurable reporting</li> <li>- Includes 3 scheduled reports</li> <li>- iWorQ Notifications included</li> <li>- Quarterly parcel update</li> <li>- OpenStreetMap tracking abilities</li> <li>- Free forms, letters, and/or permits utilizing iWorQ's template library, and up to 3 custom letters</li> </ul>		
<p>Plan Review Management</p> <ul style="list-style-type: none"> <li>- Draw &amp; annotate on plans</li> <li>- Save data in layers on plans</li> <li>- Place watermarks on plans</li> <li>- Must have premium data to use</li> </ul>	\$500.00	Annual
<p>Custom Data Plan</p> <ul style="list-style-type: none"> <li>- This agreement includes a total upload size limit of 100MB and a total usage of 200GB</li> </ul>	\$1,750.00	Annual
<p>Custom Letters</p> <p>(Total Custom Letters= 25)            Note: Additional Custom Letters can be purchased as needed:            \$500/annually for 3</p>	\$0.00	Annual
<b>Subscription Fee Total (This amount will be invoiced each year)</b>	<b>\$14,000.00</b>	Annual

### **One-Time Setup, GIS integration, and Data Conversion Fees**

<u>Service(s)</u>	<u>Package Price</u>	<u>Billing</u>
Implementation and Setup cost year 1	\$850.00	Year One
Up to 5 hours of GIS integration and data conversion	Included	Year One
Data Conversion	Included	Year One



## **NOTES AND SERVICE DESCRIPTION**

- I. Invoice for the (Annual Subscription Fee Total + One-Time Total) will be sent out immediately upon execution of the contract. Payment terms are net 30 days from the invoice date.
- II. Annual Invoice will be dated and sent 30 days prior to the period start date each year.
- III. This subscription Fee and Agreement have been provided at the Customer's request and is valid for 25 days
- IV. This cost proposal cannot be disclosed or used to compete with other companies.
- V. This agreement combines existing services totaling \$9,750 with proposed added services (Planning and Zoning-Enterprise and 100GB additional data) totaling \$6,750, Removing Permit Management-Planning and Zoning totaling \$2,500 for a new annual total of \$14,000. Added services may be prorated.

**10. CUSTOMER IMPLEMENTATION INFORMATION:**

Primary Implementation Contact Ryan Cannon Title Town Manager  
 Office Phone 317-272-0948 Cell \_\_\_\_\_ Email rcannon@avonindiana.gov  
 Secondary Implementation Contact Suzanne Hardy Title Ex. Assistant  
 Office Phone 317-272-0948 Cell 317-954-6697 Email shardy@avonindiana.gov

**11. CUSTOMER BILLING INFORMATION:**

Billing Contact Suzanne Hardy Title Ex. Assistant  
 Office Phone 317-272-0948 Cell \_\_\_\_\_ Email shardy@avonindiana.gov  
 PO# \_\_\_\_\_ (if required) Tax Exempt ID # \_\_\_\_\_

**12. ACCEPTANCE:**

The effective date of this Agreement is listed below. Authorized representative of Customer and iWorQ have read the Agreement and agree and accept all the terms.

Signature Ryan Cannon Effective Date: 8-2-2024

Printed Name Ryan Cannon  
 Title Town Manager  
 Office Number 317-272-0948  
 Cell Number 317-231-8849



## IWORQ SERVICE(S) AGREEMENT

### For iWorQ application(s) and service(s)

Avon, IN hereafter known as ("Customer"), enters into THIS SERVICE(S) AGREEMENT ("Agreement") with iWorQ Systems Inc. ("iWorQ") with its principal place of business 1125 West 400 North, Suite 102, Logan, Utah 84321.

#### **1. SOFTWARE AS A SERVICE (SaaS) TERMS OF ACCESS:**

iWorQ grants Customer a non-exclusive, non-transferable limited access to use iWorQ service(s), application(s) on iWorQ's authorize website for the fee(s) and terms listed in Appendix A. This agreement will govern all application(s) and service(s) listed in the Appendix A.

#### **2. CUSTOMER RESPONSIBILITY:**

Customer acknowledges that they are receiving only a limited subscription to use the application(s), service(s), and related documentation, if any, and shall obtain no titles, ownership nor any rights in or to the application(s), service(s), and related documentation, all of which title and rights shall remain with iWorQ. Customer shall not permit any user to reproduce, copy, or reverse engineer any of the application(s), service(s) and related documentation.

iWorQ is not responsible for the content entered into iWorQ's database or uploaded as a document or image.

#### **3. TRAINING AND IMPLEMENTATION:**

Customer agrees to provide the time, resources, and personnel to implement iWorQ's service(s) and application(s). iWorQ will assign a senior account manager and an account management team to implement service(s) and application(s). Typical implementation will take less than 60 days. iWorQ account managers will call twice per week, provide remote training once per week, and send weekly summary emails to the customer implementation team. iWorQ can provide project management and implementation document upon request.

iWorQ will do ONE import of the Customer's data. This import consists of importing data, sent by the Customer, in an electronic relational database format.

Customer must have clear ownership of all forms, letters, inspections, checklists, and data sent to iWorQ.

#### **4. CUSTOMER DATA:**

Customer data will be stored on AWS GovCloud. iWorQ will use commercially reasonable efforts to backup, store and manage Customer data. iWorQ does backups twice per week and offsite backups twice per week. The subscription will renew each year on the anniversary date of this Agreement unless terminated (see 7. TERMINATION).

Customer can run reports and export data from iWorQ application(s) at any time.

Customer can pay iWorQ for additional data management service(s), onsite backups, application(s) and other service(s).

Data upload and storage is provided to every Customer. This includes uploading files up to 25MB and 100GB of managed data storage on AWS GovCloud. Additional upload file sizes and managed data storage sizes can be provided based on the application(s) and service(s) listed in Appendix A.

Customer can upload and store images with personal information like driver's license, and more. This Data can be used by the customer to complete the permitting, licensing, or code enforcement processes. Customer understands that the data must be uploaded and stored in the Sensitive Data Upload section of the iWorQ software for access and security purposes.

iWorQ is not responsible: (1) For the content entered into iWorQ's database, (2) For images or documents scanned locally and uploaded by the iWorQ users, (3) For documents or images uploaded by citizens over the web, and (4) For backup data sent to the Customer by iWorQ.

#### **5. CUSTOMER SUPPORT:**

Customer support and training are FREE and available Monday-Friday, from 6:00 A.M. to 5:00 P.M. MST, for any authorized user with a login. iWorQ provides unlimited remote Customer training (through webinars), phone support, help files, and documentation. Basic support request is typically handled the same day. iWorQ provides "Service NOT Software".

#### **6. BILLING:**

iWorQ will invoice Customer on an annual basis. iWorQ will send invoice by mail and by email to the address(s) listed in Appendix A. Terms of the invoice are net 30 days from the date of the invoice. Any billing changes will require that a new Service(s) Agreement be signed by Customer.

Any additional costs imposed by the Customer including business licenses, fees, or taxes will be added to the Customer's invoice yearly. Support and services fees may increase in subsequent years but will increase no more than 5% per year.

Customer pricing is based on a 3 Year Term and reflects a discounted annual price. Changes to the Term or the Termination Policy (Section 7. Termination:), will affect the annual pricing and could double your annual cost. Customer reserves the right to pay the 3 Year Term upfront to secure discounted annual pricing.

## **7. TERMINATION:**

Prior to the expiration of the initial 3-YEAR TERM (the "Initial Term"), either party may terminate this Agreement, by providing the other party with a Sixty (60) days' written notice prior to the effective date of the expiration. Should Customer terminate any part of the application(s) and or service(s) the remaining balance will immediately become due. Should Customer terminate any part of the application(s) and or service(s) a new Service(s) Agreement will need to be signed. Upon expiration of the Initial Term, this Agreement shall automatically renew for successive one (1) year terms unless either party provide notice of termination or non-renewal no less that sixty (60) days prior to expiration of the then-current term.

Upon termination of this Agreement, iWorQ will discontinue all application(s) and or service(s); iWorQ will provide customer with an electronic copy of all of Customer's data, if requested by the Customer (within 3-5 business days).

During the term of the Agreement, the Customer may request a copy of all of Customer's data, which shall be provided to Customer for a cost of no more than \$2500 per copy. Please note, if Customer is not in compliance with the material terms and conditions of this Agreement, iWorQ will not be required to provide Customer with the data.

## **8. ACCEPTABLE USE:**

Customer represents and warrants that the application(s) and service(s) will only be used for lawful purposes, in a manner allowed by law, and in accordance with reasonable operating rules, and policies, terms, and procedures. iWorQ may restrict access to users upon misuse of application(s) and service(s).

## **9. MISCELLANEOUS PROVISIONS:**

This Agreement will be governed by and construed in accordance with the laws of the State of Utah.

Customer recognizes that iWorQ Systems is a software company located in Utah. Any changes to this section, including changes to the Venue or Forum, will be subject to an increase in their annual pricing.



# **iWorQ Service(s) Agreement**

## **APPENDIX A**

# iWorQ Cost Proposal

<b>Avon, IN</b>	<b>Population- <u>16960</u></b>
<b>6570 E US Highway 36 Avon, IN 46123</b>	<b>Prepared by: Nathan Romrell</b>

## Annual Subscription Fees

<u>Application(s) and Service(s)</u>	<u>Package Price</u>	<u>Billing</u>
<b>Community Development (Basic)</b> *Permit Management *Code Enforcement  -Available on any computer, tablet, or mobile device using Chrome Browser -Track permits and cases with customizable reporting -Track fees and payments -Inspection and plan review tracking -Track violations, activities and follow ups -OpenStreetMap tracking abilities with quarterly updates -Free forms, letters, and/or permits utilizing iWorQ's template library, and up to 3 custom letters	<del>\$5,197.00</del> \$4,250.00	Annual
<b>Payment Processing (Payroc)</b> - Online Credit/debit card processing - Payments are recorded and tracked in iWorQ - iWorQ's reporting tool can track all historical transactions	\$1,000.00	Annual
<b>Permit Management - Planning and Zoning</b> - Available on any computer, tablet, or mobile device using Chrome browser - Notifications can be sent from GIS map inside iWorQ - OpenStreetMap - Manage appeals, variances, plat applications, conditional use permits, etc. - Fee payments - Reporting - Quarterly parcel upload - Includes unlimited access to 15 letter templates and 3 custom letters	<del>\$3,750.00</del> \$2,500.00	Annual
<b>Plan Review Management</b> - Draw & annotate on plans - Save data in layers on plans - Place watermarks and stamps on plans	\$500.00	Annual
<b>Premium Data Package</b> - Allows for 25MB file upload size - Provides 100GB of storage	\$500.00	Annual
<b>Additional Letters</b> - Adds additional letters to the account equal to the amount listed under item IV in the notes section below	<del>\$2,200.00</del> \$0.00	Annual
<b>Large File Upload - Custom</b> - Increases upload size capabilities to the amount listed under item IV below.	\$1,000.00	Annual
<b>Subscription Fee Total (This amount will be invoiced each year)</b>	<b>\$9,750.00</b>	

## One-Time Setup, GIS integration, and Data Conversion Fees

<u>Service(s)</u>	<u>Full Price Cost</u>	<u>Package Price</u>	<u>Billing</u>
-------------------	------------------------	----------------------	----------------

### NOTES SERVICE(S) DESCRIPTION

- I. Invoice for the (Annual Subscription Fee Total + One-Time Total) will be sent out 2 weeks after signature and Effective Date
- II. This subscription Fee and Agreement have been provided at the Customer's request and is valid for 25 days
- III. This cost proposal cannot be disclosed or used to compete with other companies.
- IV. This agreement includes a total of 25 Letters and a file upload size of 100GB.
- V. This agreement combines existing services totaling \$9,250 with proposed added services (100MB upload) totaling \$500 for a combined annual total of \$9,750. Added services may be prorated.

	Items	Total Estimate	Approved
<b>3 OTHER SERVICES AND CHARGES</b>			
P/Z/B Consultant			
Legal		30,000	
Long Range Planning Update UDO		40,000	
Printing Advertising		4,300	
Liability Insurance		-	
Vehicle Fuel			
Repairs/Maintenance			
Code Enforcement Mowing		5,000	
Dues & Subscriptions		3,000	
Cellular 7		4,200	
Refunds			
Computer Consulting IWORQ/GIS		17,000	
Building Maintenance		15,000	
Document Scanning/Digitize files		40,000	-
		-	-
<b>Total Other Services and Charges</b>		<b>158,500</b>	

	Items	Total Estimate	Approved
<b>4 CAPITAL OUTLAYS</b>			
		-	-
		-	-
		-	-
Total Capital Outlays		-	
<b>TOTAL BUDGET ESTIMATE</b>	832,779	<b>886,534</b>	-
		6.5%	53,755

(I) (We) hereby certify that the foregoing is a true and fair estimate of the necessary expense of the

(Name of Office, Board, Commission, Department, Institution or Fund)

for the calendar year 2026 for the purposes therein specified.

Dated this \_\_\_\_\_ day of \_\_\_\_\_, 20\_\_.

\_\_\_\_\_  
 \_\_\_\_\_  
 \_\_\_\_\_  
 \_\_\_\_\_

Signature and Title of Officer(s)  
 or Department Head

TOWN OF AVON  
EXPENSE ACCOUNT SUMMARY  
101 GENERAL FUND

Account Title Number	Appropriation Transfers	February 2026		Prev.Yr Per Prev.Yr YTD	Encumbered % Expended YTD	Uncommitted Unexpended
		Revisions Revised Appro	Per Expense YTD Expense			
1101.104.421.101	0.00	1,000.00	67.98	172.48	6.80	932.02
POSTAGE	1,000.00	0.00	0.00	19.10	0.00	1,000.00
1101.104.421.102	0.00	1,000.00	0.00	19.10	0.00	1,000.00
MISC SUPPLIES	0.00	0.00	1,293.00	0.00	0.00	(1,324.44)
1101.104.421.103	0.00	0.00	1,324.44	503.00	0.00	(1,324.44)
LEGAL	30,000.00	0.00	0.00	3,207.50	0.00	29,118.00
1101.104.431.103	0.00	30,000.00	882.00	5,726.75	2.94	29,118.00
LONG RANGE PLANNING	40,000.00	0.00	855.00	0.00	17,476.12	40,000.00
1101.104.431.104	19,876.24	59,876.24	2,400.12	8,514.54	4.01	57,476.12
COMPUTER CONSULTING	17,000.00	0.00	0.00	0.00	15,000.00	17,000.00
1101.104.431.108	15,000.00	32,000.00	0.00	0.00	0.00	32,000.00
CELLULAR	4,200.00	0.00	0.00	0.00	0.00	4,200.00
1101.104.432.106	0.00	4,200.00	0.00	0.00	0.00	4,200.00
PRINTING ADVERTISING	4,300.00	0.00	94.69	0.00	0.00	4,113.37
1101.104.433.101	0.00	4,300.00	186.63	0.00	4.34	4,113.37
BUILDING MAINTENANCE	15,000.00	0.00	270.00	869.00	0.00	14,730.00
1101.104.436.101	0.00	15,000.00	270.00	932.99	1.80	14,730.00
DUES AND SUBSCRIPTION	3,000.00	0.00	65.00	0.00	0.00	2,865.00
1101.104.439.103	0.00	3,000.00	135.00	0.00	4.50	2,865.00



MakeMyMove will continue supporting the Town of Avon to achieve the previously established goal of 10 households. Avon currently has moved 7 with a healthy pipeline of 2 in accepted and 3 in offered status.

MakeMyMove would like to propose working with Avon to conduct a twelve (12) month program to generate and recruit a pool of qualified applicants to live in your community. The goal of the new program will be to relocate five (5) new households to live and work in Avon.

### FLOW OF FUNDS

In consideration for the products and services provided, MakeMyMove shall be compensated \$55,000. Upon grant approval, MakeMyMove shall issue an invoice to the IEDC in the amount of \$29,750, representing the first half of the State’s financial commitment and retain in full.

The initial payment of \$12,625 will be due based on an agreed upon date after the program commences. The final payment of \$12,625 is typically due 60 days after the initial payment.

Upon the successful relocation of three (3) households, representing the program’s halfway milestone, MakeMyMove shall issue a second invoice to the IEDC for \$29,750. MakeMyMove will transfer the total second tranche of IEDC grant funds to Avon, which will be used for the remainder of the program’s mover stipends and soft incentives.

The Town of Avon’s total out-of-pocket investment is \$25,500 to recruit and move 5 new households in addition to fulfilling the remaining 3 new households from the previous contract.

<b>5 New Households</b>		
<i>Avon Program Start</i>	TBD	
<i>IEDC to MMM</i>		\$29,750
<i>Avon to MMM 30 days after signed contract</i>	\$12,625.00	
<i>Avon to MMM 60 days after 1st payment</i>	\$12,625.00	
<i>IEDC to MMM to Avon after 3 new movers</i>		\$29,750
<i>Avon to Movers (over time)</i>	\$30,000	
<i>Subtotal</i>	\$55,250	\$29,750
<i>Avon Total Cost</i>	\$25,500	



**MakeMyMove**

# Progress Report

# Investment vs. Impact

*For every \$1 invested, \$6.74 were generated in Year 1 alone.*

**\$425.3K**

Total New Annual Economic  
Output Generated

**\$63.1K**

(Community) dollars invested:  
fixed plus performance costs less  
matching funds distributed

Total New Annual Economic Output

**\$53.4K**

Total New Annual State and Local  
Tax Revenue

*Economic Outputs are generated by IMPLAN*

# Economic Impact Dashboard

Annual Economic Impact ⓘ  
**\$425.3K**

5-Year Economic Impact ⓘ  
**\$1.8M**

Annual Tax Contribution ⓘ  
**\$53.4K**

Annual Jobs Created ⓘ  
**4.5**

Estimated-to-Date + Projected Future Economic Impact

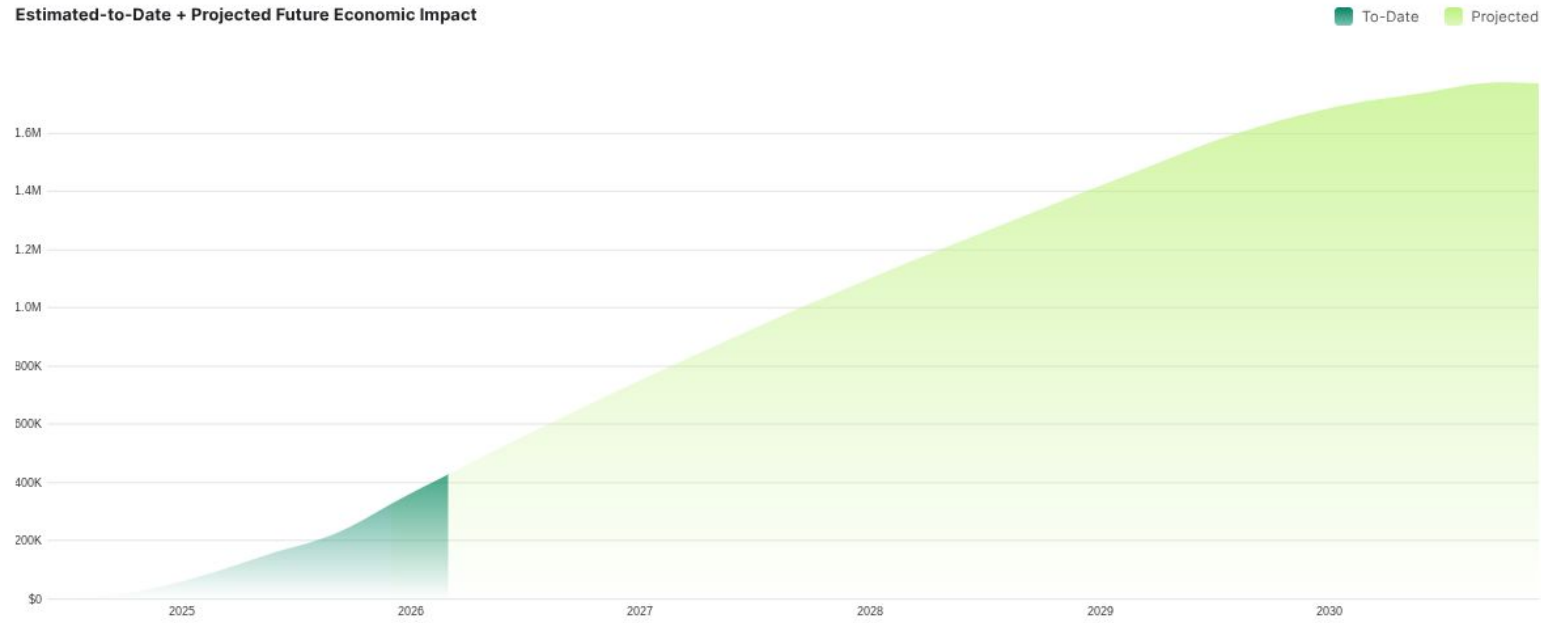

Potential New Residents ⓘ  
In the Pipeline  
**215**

Potential Economic Value ⓘ  
In the Pipeline  
**\$5.0M** / YEAR

Potential Value by Candidate Status:

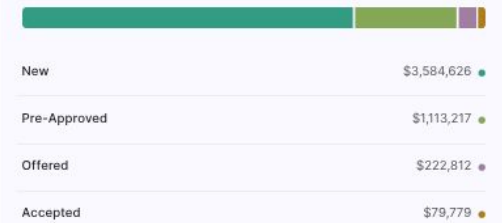

Economic Impacts are generated by IMPLAN

# Your Movers

**New  
Household  
s**

**7**

**New  
People**

**18**

**Committed  
Movers**

**2**

**Offers  
Pending**

**3**

# Your Movers

First Name	Last Name	Profession	Household Income	Moved From	Adults	Children	Total People
Michael	Masten	Business Analyst	\$300,000	Golden, CO	4	3	7
Rachel	Borgen	Corporate Trainer	\$60,996	Surprise, AZ	2	0	2
GG	Monai	Remote Insurance Agent	\$50,000	Steger, IL	1	3	4
Ethan	Quam	Construction Application Specialist	\$140,000	South Dakota	2	0	2
Amanda	Ruby	Senior Total Loss Customer Care	\$70,000	Phoenix, AZ	1	0	1
Charles	Sanders	Technical Services Engineer	\$65,000	Goodyear, AZ	1	0	1
Angelica	Northup	Marketing	\$57,000	San Diego, CA	1	0	1

# Mover Testimonial

I moved to Avon, IN from San Diego, CA about two months ago with the MakeMyMove program. After years of sunny and 75°, I decided a white Christmas wouldn't be so bad if I got to spend more time with my favorite nieces who live just one town over. But as a dedicated beach goer, what I didn't expect was to fall in love with the Midwest nature. The conveniently located and beautifully maintained park systems in Indiana are truly unlike any I've encountered - I think the only one more impressed than I am is my trusty sidekick, Lucky, who now gets to spend his afternoons chasing squirrels instead of evading city traffic.

*Angelica Northup*

*San Diego, CA → Avon, IN*



# Marketing- MakeMyMove Marketplace

## Commentary

Reach 

Data is refreshed every 24 hours

All Time 



Applications

**481**

**291 Met Your Criteria**

Movers who meet your program's eligibility criteria are viewable in your Pipeline.



Likes

**1.7K**

Program Likes

**1.5K**

Community Likes

**273**



Impressions

**625.2K**

Program Impressions

**213.8K**

Community Impressions

**411.4K**

# Marketing- Earned Media

Press  
Reach

78.8M

Press  
Value

\$725K

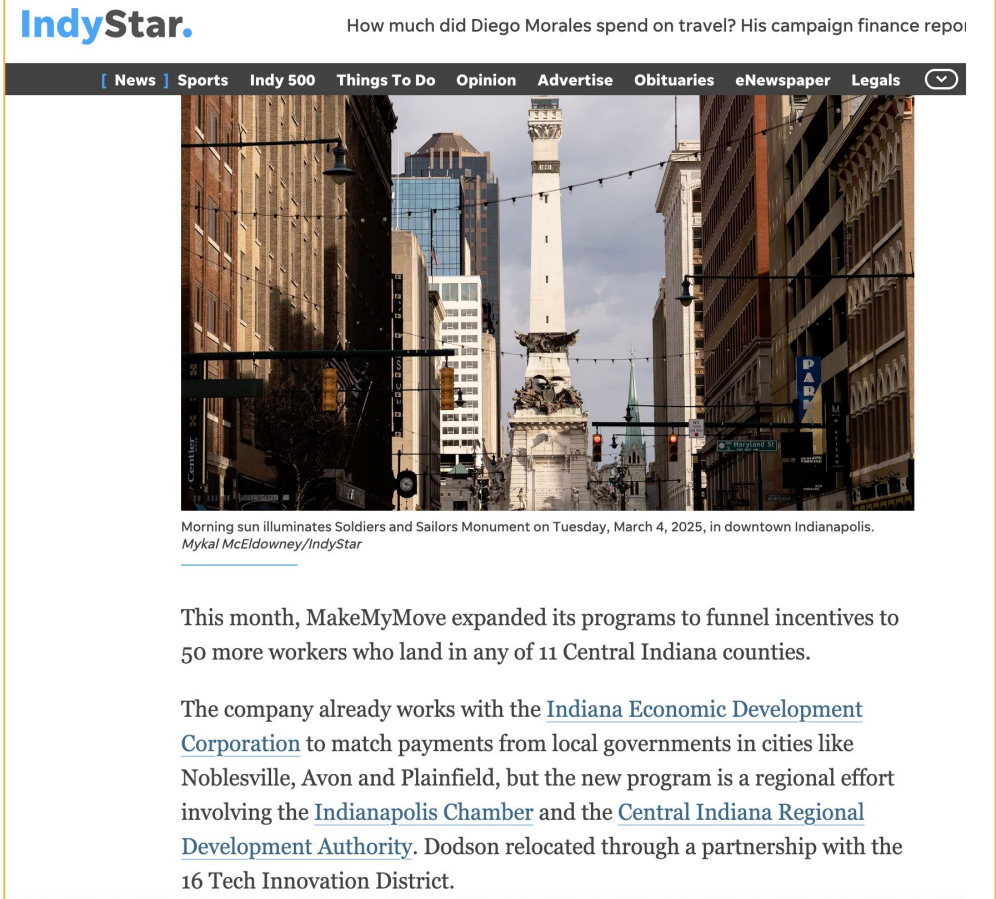

The screenshot shows a news article on the IndyStar website. The headline is "How much did Diego Morales spend on travel? His campaign finance report". The article includes a photograph of the Soldiers and Sailors Monument in downtown Indianapolis. The text of the article discusses how MakeMyMove expanded its programs to funnel incentives to 50 more workers in 11 Central Indiana counties, mentioning partnerships with the Indiana Economic Development Corporation, Indianapolis Chamber, and Central Indiana Regional Development Authority.

**IndyStar.** How much did Diego Morales spend on travel? His campaign finance report

[ News ] Sports Indy 500 Things To Do Opinion Advertise Obituaries eNewspaper Legals

Morning sun illuminates Soldiers and Sailors Monument on Tuesday, March 4, 2025, in downtown Indianapolis.  
*Mykal McEldowney/IndyStar*

This month, MakeMyMove expanded its programs to funnel incentives to 50 more workers who land in any of 11 Central Indiana counties.

The company already works with the [Indiana Economic Development Corporation](#) to match payments from local governments in cities like Noblesville, Avon and Plainfield, but the new program is a regional effort involving the [Indianapolis Chamber](#) and the [Central Indiana Regional Development Authority](#). Dodson relocated through a partnership with the 16 Tech Innovation District.

# Avon and Comparable Communities

Metric	Comparative communities	Avon	% variance
% Eligibility Confirmed	29.33%	51.79%	+76%
% Offered	26.97%	51.79%	+92%
% Accepted	8.69%	16.07%	+85%
% Moved	3.43%	4.17%	+21%

\*Lead rates calculated for Leads April 1, 2024 - December 31, 2025

## What This Data Shows

Applicants who discover Avon through MakeMyMove are moving through the pipeline faster and at higher rates than applicants in comparable communities. This performance demonstrates that MakeMyMove is not just generating interest, but attracting qualified movers who are ready to take action.

## How Avon Can Continue to Maximize This Value

- **Increased use of the Recruitment Tool** enables timely, personalized outreach to high-intent applicants, helping sustain strong conversion rates as lead volume grows.
- **Stronger partnerships with local realtors and landlords** help remove housing friction earlier in the process, allowing motivated applicants to move forward more quickly.
- **Strategic enhancements to the incentive package**—particularly family-focused and community-connectedness perks—can keep the offer competitive and compelling, reinforcing Avon's strong funnel performance.

# What We're Learning

We've learned a lot since the program started.

## **Strong local support is critical.**

From the program owner to locals to businesses contributing to the incentive, it all adds to the story of your community and the success of the program. The most successful communities are invested, consistent and above all, welcoming.

## **The importance of an engaged program owner**

Having an engaged program owner who actively manages the pipeline and communicates effectively with movers is crucial for a successful program.

## **Retention, retention, retention.**

This starts with building the offer. The offer becomes less about 'what you get' and more about 'how you connect.' When a mover arrives, make them feel special! Deliver on what was promised in a timely manner, but how can you turn them into Avon's #1 fan?

## **Applicants do their research.**

Applicants are consulting many sources to learn about their potential new homes - from community Facebook pages, to Reddit threads, and Google. Poor online presence can have an impact on pipeline throughput.

# Pipeline Opportunity

There are **24** active applicants in your pipeline. Of those, **5** are late stage candidates and are either being reviewed for an offer, have an offer, or have accepted an offer to join your program. All-time, you have received **481** total applicants.

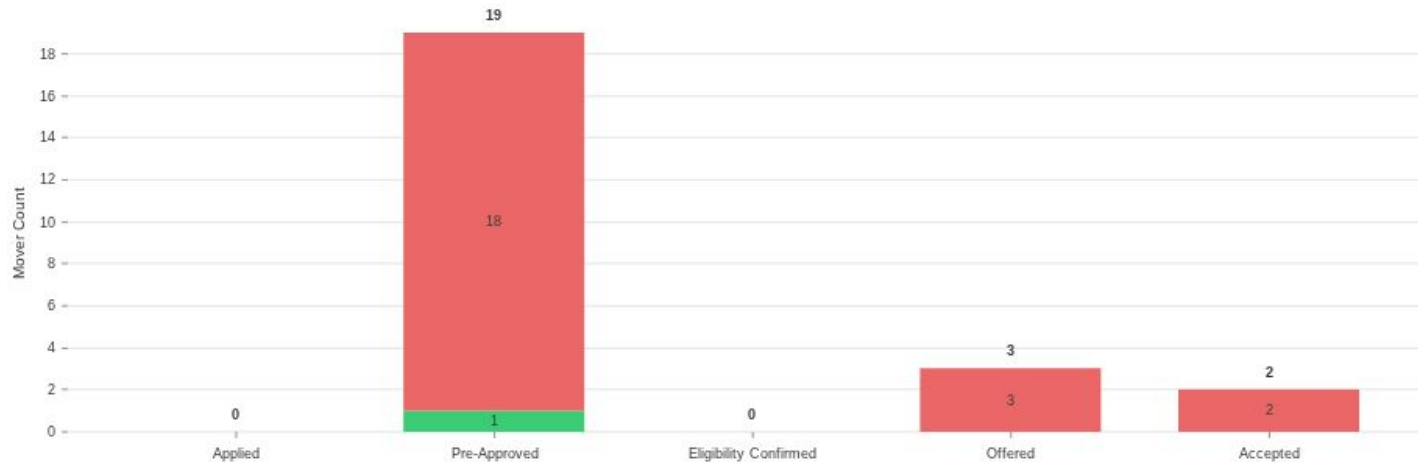

Those **5** late stage candidates represent...

**\$303K**

Of New Annual Economic  
Impact Opportunity

**\$93K**

Average Household Income

**5**

Different States

# Proposed Timeline

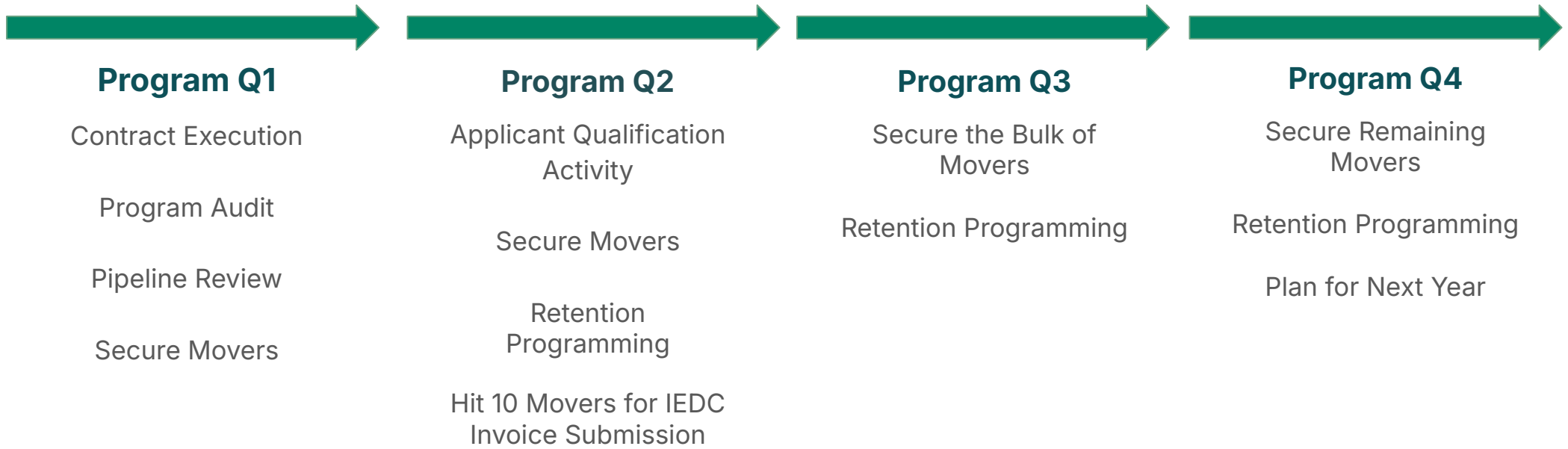
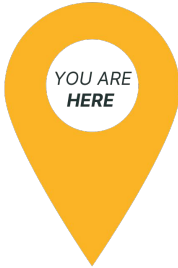

Thank You



**THANK YOU**





## MakeMyMove Product and Services Agreement

This Product and Services Agreement (the "**Agreement**") is made and entered into by and between:

**TMAP, LLC, dba MakeMyMove**, an Indiana Limited Liability Company, with its principal place of business at 1003 E 38th St. Indianapolis, IN 46205 ("**MakeMyMove**"),

And [**The Town of Avon**], with its principal place of operations at [6570 East US Highway 36. Avon, IN 46205] ("**Client**").

### Summary

**MakeMyMove** is an economic development platform that helps communities grow by recruiting talented people and their families to relocate. Our tools and team make it easy for a community to grow its workforce & economy, one household at a time.

[**The Town of Avon**] focuses on fostering a vibrant community where residents and visitors enjoy living and recreating, while also preserving its historic resources and natural environment.

Together, we will develop and execute a 12-month talent attraction program with the shared goal of moving **5 new** Qualified Households\* to live and work in Avon, IN.

### Candidate Qualification Criteria

	<b>Job-Bringer</b>	<b>Job-Seeker</b>
<b>Description</b>	Household for which the primary worker is fully remote, makes the minimum income, and is able to continue working for the minimum duration.	Household for which the primary worker accepts a job with a local employer making the minimum income, and works for the minimum duration.
<b>Minimum Income</b>	\$50,000	50,000
<b>Move-from Boundary</b>	Outside of State of Indiana	Outside of State of Indiana
<b>Move-to Boundary</b>	Town of Avon	Town of Avon
<b>Required Duration</b>	1 Year	1 Year

Products and Services	What's Included?	Price
<b>12-Month *High-Volume **Tier-2 Platform Subscription and Talent Attraction Campaign</b>	<ol style="list-style-type: none"> <li>1. <b>Premium microsite on MakeMyMove.com</b> highlighting your relocation program and the people &amp; places that make Avon special.</li> <li>2. <b>Promotion</b> of your regional content to a high-quality audience of move-ready talent across the MakeMyMove platform, online and via email &amp; digital channels.</li> <li>3. <b>Access to QuickApply</b>, the conversion-friendly, configurable and integrated application form.</li> <li>4. <b>Unlimited seats for Mover Recruitment Studio</b>, the purpose-built talent attraction tool. Key features include: <ol style="list-style-type: none"> <li>4.1. A pipeline pre-qualified leads for your community with rich candidate data.</li> <li>4.2. CRM tools to manage the leads through the recruitment process.</li> <li>4.3. Recruitment &amp; retention playbooks to guide your program's activity.</li> <li>4.4. Message templates and workflow automation for ease-of-use.</li> <li>4.5. Integrated support to answer questions and shoulder the burden of care.</li> </ol> </li> <li>5. <b>Access to MakeMyMove's ROI Dashboard</b> for real-time monitoring of the economic impact and reach of your relocation program.</li> <li>6. <b>Marketing &amp; Communications:</b> Our team of consumer marketing experts will help you develop and deploy the right message to engage and convert your target audience. Services include: <ol style="list-style-type: none"> <li>6.1. Provide advice to construct an effective program</li> <li>6.2. Develop unique positioning for your region's program including a memorable 'hook' to grab users' attention.</li> <li>6.3. Develop SEO-friendly content for your pages to help tell the story of your region.</li> <li>6.4. Identify newsworthy content and pitch it to media outlets to earn press for your program.</li> <li>6.5. Run digital ad campaigns to drive impressions to your content.</li> </ol> </li> <li>7. <b>Program Support:</b> Your dedicated Customer Success team will help you get your program running, and ensure that you have the data and know-how to recruit and retain people effectively. Services include: <ol style="list-style-type: none"> <li>7.1. Ongoing management of pages on makemymove.com.</li> <li>7.2. Monitoring and curation of locally generated content.</li> <li>7.3. Customized recruitment and retention playbooks, and advice from a team of recruitment experts on how to run your program most effectively.</li> <li>7.4. Performance monitoring, and analysis of data and trends.</li> <li>7.5. Regular update meetings and available customer support line.</li> </ol> </li> </ol>	\$55,000



	<p>8. <b>Fulfillment:</b> Landing new recruits requires diligence and a welcoming spirit. Our team will support the effort with expert customer care and community activation.</p> <p>8.1. The Mover Support Team will work with recruits to navigate the relocation process, answer questions, and connect them to relevant local resources.</p> <p>8.2. Verify candidate eligibility by confirming employment &amp; income, and conducting criminal background checks.</p> <p>8.3. Activate community members by identifying and training local volunteers to provide content and assist in the recruitment process.</p> <p>9. <b>Economic Modeling:</b> Using IMPLAN, the industry standard input output model, we'll build economic impact reports to show the incremental output of the new residents and jobs your program attracts.</p>	
<p><b>One-Time Setup + Implementation Services</b></p>	<p>1. <b>Content Development:</b> We'll set up initial program and community pages on makemymove.com, and invite locals to contribute testimonials &amp; user generated content.</p> <p>2. <b>System Configuration:</b> We'll create an instance of the Mover Recruitment Studio to suit your needs, and ensure that each relevant team member has sufficient access, and understanding of the tools.</p> <p>3. <b>Onboarding and Training:</b> We'll conduct orientation meetings to ensure relevant stakeholders understand the process, and will hold training sessions to help members of the recruitment team understand their roles, and the tools available to make their job easier.</p> <p>4. <b>Program Development:</b> We'll provide ongoing consulting services to help develop and improve the relocation programming on offer.</p>	
<p><b>Mover Volume Target</b></p>	<p>1. The marketing, content and fulfillment services have been scoped to support a campaign that would generate <b>5 new</b> movers, assuming standard eligibility, programming and expected conversion rates*</p>	<p>\$11,000</p>

## COMPENSATION & PAYMENT SCHEDULE

In consideration for the products and services provided, MakeMyMove shall be compensated \$55,000. Upon grant approval, MakeMyMove shall issue an invoice to the IEDC in the full amount of \$29,750, representing the first half of the State's financial commitment and retain in full.

The initial payment of \$12,625 will be due on April 1, 2026. The final payment of \$12,625 is due 60 days after the initial payment.



Upon the successful relocation of three (3) households, representing the program's halfway milestone, MakeMyMove shall issue a second invoice to the IEDC for \$29,750. MakeMyMove will transfer the total second tranche of IEDC grant funds to Avon, which will be used for the remainder of the program's mover stipends.

	Avon Program Cost		\$119,000			
	Mover Goal		5			
	Avon Responsibility	IEDC Responsibility				
Total	\$59,500	\$59,500				
In Kind	\$34,000	N/A				
Cash	\$25,500	\$59,500	\$85,000			
	Amount	Date	Payor	Payee	Notes	
State Funding Part 1	\$29,750.00	upon signature from community	IEDC	MMM		
Avon Payment 1	\$12,625.00	due 30 days after signature	Client	MMM		
Avon Payment 2	\$12,625.00	due 90 days after signature	Client	MMM		
State Funding Part 2	\$29,750.00	upon reaching mover #3	IEDC	MMM	MMM will send funds to Avon to use for mover incentives	
Avon payments payments to movers	\$250.00		Client	Movers	In addition to the state funds, Avon will pay this toward movers incentives	
	\$85,000.00					
Reimbursements						
Avon Reimbursement	\$29,750		MMM	Client	MMM will send the full second tranche of funds to Avon to be used for mover incentives	

## TERMS AND TERMINATION

The term of this agreement commences on April 1, 2026, The recurring portions will automatically renew on the 1-year anniversary of that date unless cancelled prior. Upon cancellation, Avon will retain access to the Mover Recruitment Studio and relevant applicant/lead data for up to 90 days to facilitate a successful transition.

Either party may cancel this agreement upon 90 days written notice to the other party at any time. Upon early termination by the Client, Client agrees to relieve MakeMyMove of the liability to fulfill the remainder of the contracted products and services. MakeMyMove will suspend recruitment activities on behalf of the Client, and will relieve Client of its obligation for future payments related to unfulfilled portions of the product and services.

## OWNERSHIP OF DOCUMENTS AND MATERIALS

Except for MakeMyMove's Intellectual Property which includes but is not limited to the MakeMyMove Platform, Recruitment Playbooks & Campaign Methodology, all documents, content, records, programs, data, articles, memoranda, and other materials (the "Materials") specifically developed pursuant to or in connection with the services performed by MakeMyMove under this Contract shall be considered "work for hire" and MakeMyMove hereby transfers and assigns any ownership claims to the Client so that all Materials will be the property of the Client.



## APPLICANT & LEAD DATA

Through the use of the platform, Recruitment Candidates who engage with Client's program, and community content on makemymove.com give MakeMyMove permission to share their personal information with the client for the purposes of evaluating and participating in the Client's relocation program. Recruitment Candidates retain full ownership of their personal information. Client will have access to candidate information pursuant to the MakeMyMove Privacy Policy. Candidate Information may not be used for any other purpose, or be shared with a third party without the direct, written consent of the candidate.

## CONFIDENTIALITY

"Confidential Information" means (i) any information regarding Client's and MakeMyMove's current employees, and policies, (ii) any information concerning the existing or future products of Client or MakeMyMove; (iii) the terms of this Agreement, (iv) any software, documentation, materials or information provided shared in order to assist performing the services; and (v) any additional information designated in writing as "confidential" by Client or MakeMyMove. Confidential Information will not include, however, any information described above to the extent any of the following may be included therein: (1) information that becomes known to the general public without breach of the non-disclosure obligations of this Agreement; (2) information that is obtained from a third party or independently developed without breach of a nondisclosure obligation and without restriction on disclosure; and (3) information that is required to be disclosed in connection with any suit, action or other dispute related to this Agreement.

MakeMyMove and Client mutually agree to hold in confidence, and not to use except as expressly authorized in this Agreement, all Confidential Information and to use reasonable care to prevent the unauthorized disclosure or use of the other party's Confidential Information, both during and after the term of this Agreement.

## EQUAL OPPORTUNITY EMPLOYER POLICY

Both the Client and MakeMyMove are Equal Opportunity Employers, and each of the parties endeavors to recruit applicants for relocation and/or employment without regard to race, color, religion, age, sex, marital status, sexual preference, national origin, physical or mental disability, or veteran status.

## INDEMNIFICATION



The indemnified Party shall provide the indemnifying Party with prompt written notice of any such indemnification claim. The indemnifying Party shall have sole control and authority with respect to the defense and settlement of any such claim. The indemnified Party shall cooperate fully with the indemnifying Party, at the indemnifying Party's sole cost and expenses, in the defense of any such claim. The indemnifying Party shall not agree to settle any such claim that does not include a complete release of the indemnified Party from all liability with respect thereto or that imposes any liability, obligation or restriction on the indemnified Party without the prior written consent of the indemnified Party. The indemnified Party may participate in the defense of any claim through its own counsel, and at its own expense.

#### GENERAL TERMS

MakeMyMove is an independent contractor, and nothing in this Agreement will be deemed to place the parties in the relationship of employer-employee, principal-agent, partners or joint venturers. MakeMyMove will be responsible for all tax withholdings.

Dispute Resolution. Any controversy, dispute or claim arising out of or relating to this contract shall first be settled through good faith negotiation. If the dispute cannot be settled through negotiation, the parties agree to attempt in good faith to settle the dispute by mediation; the mediator in such an instance shall have no authority to modify the terms of this Agreement. The mediation proceeding shall be held at a location mutually agreed to by the parties in writing. The administrative cost of the mediation and the mediator's fee shall be shared equally by the parties. If the parties are unsuccessful at resolving the dispute through mediation, the parties agree that the method of subsequent dispute resolution will be in a court of competent jurisdiction. If a dispute proceeds to litigation, the prevailing party is also entitled to recover attorneys fees and court costs in addition to any other recovery (including reasonable attorney's fees) which either party shall sustain as a result of the other's negligent acts, errors or omissions in carrying out the responsibilities in this Agreement.

Governing Law. This Agreement will be governed by and interpreted under the laws of the State of Indiana, without giving effect to applicable conflicts of law principles. Survival. The provisions of the Presentation, Confidentiality, and General Terms sections shall survive the expiration or termination of this Agreement.

Client: By (Sign)\_\_\_\_\_



Name: Ryan Cannon

Title: Town Manager

MakeMyMove: By (Sign) \_\_\_\_\_

Name: Ryan Pike

Title: Senior Sales Director

#### NOTICE ON PRICING & PERFORMANCE

\*Pricing and performance of recruitment programs vary based upon factors such as the size and population of a region, the relative value of relocation programming, candidate qualification criteria and the level of participation from local program owners and volunteers. MakeMyMove scopes the size of our product and services offering to deliver the appropriate number of moved households under normal circumstances, and we set individual pricing based upon the expected marketing cost to produce qualified leads for a region of similar size, and our expected ability to convert those leads to movers based on average performance of similar communities.

TOWN OF AVON  
EXPENSE ACCOUNT SUMMARY  
4436 EDIT FUND

Account Title Number	Appropriation Transfers	Revisions Revised Appro	February 2026 Per Expense YTD Expense	Prev.Yr Per Prev.Yr YTD	Encumbered % Expended YTD	Uncommitted Unexpended
MARCOMM INTERN	8,000.00	0.00	0.00	7,301.42	0.00	(5,701.58)
4436.101.411.109	0.00	8,000.00	13,701.58	14,528.15	171.27	(5,701.58)
MAIN ST. COORDINATOR	64,480.00	0.00	0.00	5,769.22	0.00	64,480.00
4436.301.411.111	0.00	64,480.00	0.00	11,479.77	0.00	64,480.00
FICA	612.00	0.00	443.68	942.32	0.00	(1,301.13)
4436.301.413.101	0.00	612.00	1,913.13	1,876.20	312.60	(1,301.13)
RETIREMENT	7,093.00	0.00	0.00	1,437.78	0.00	6,476.16
4436.301.413.103	0.00	7,093.00	616.84	2,854.62	8.70	6,476.16
GROUP INSURANCE	29,000.00	0.00	703.97	2,371.67	0.00	25,886.83
4436.301.413.105	0.00	29,000.00	3,113.17	4,743.34	10.74	25,886.83
HSA TOWN CONTRIBUTIONS	128,750.00	0.00	0.00	0.00	0.00	73,750.00
4436.301.413.115	0.00	128,750.00	55,000.00	106,250.00	42.72	73,750.00
LEGAL	65,000.00	0.00	40,000.00	1,249.50	0.00	65,000.00
4436.301.431.101	40,000.00	105,000.00	40,000.00	1,582.50	38.10	65,000.00
ECON DEV CONSULTING	30,000.00	0.00	0.00	0.00	0.00	30,000.00
4436.301.431.104	0.00	30,000.00	0.00	0.00	0.00	30,000.00
EDIT CONTRACTUAL SERVICE	32,177.00	0.00	0.00	17,667.40	0.00	24,177.00
4436.301.431.109	0.00	32,177.00	8,000.00	23,667.40	24.86	24,177.00
<b>EDIT CONTR. DEPT. SERVICES</b>	<b>113,139.00</b>	<b>0.00</b>	<b>0.00</b>	<b>0.00</b>	<b>0.00</b>	<b>94,515.00</b>

## **Avon Town Council**

### **Resolution 2026-09**

#### **Approving Purchase Agreement for Real Estate Purchase from AVON MAP, LLC**

**Whereas**, AVON MAP, LLC owns certain real estate and improvements located at 8217 Kington Street, Avon, Hendricks County, Indiana 46123 (the "Property"); and

**Whereas**, AVON MAP, LLC desires to sell the Property to the Town of Avon, pursuant to the terms of the purchase agreement attached as Exhibit A; and

**Whereas**, the Town desires to purchase the Property from AVON MAP, LLC, pursuant to the terms of the purchase agreement, for the purpose of operating a police substation and training facility; and

**Whereas**, the Town has complied with procedures required by Indiana Code §36-1-10.5 et. seq. for the purchase of land and structures; and

**Whereas**, the Town Council finds that it is in the best interest of the Town, and its citizens, to authorize the execution of a purchase agreement between the Town and AVON MAP, LLC for the purchase of the Property from AVON MAP, LLC by the Town, subject to parties' mutual acceptance of said purchase agreement and its terms and conditions; and

**Whereas**, the Town Council further authorizes the Town Manager, Ryan Cannon, to execute the purchase agreement on behalf of the Town Council, subject to the parties' mutual acceptance and finalization of said purchase agreement; and

**Whereas**, the Town Council further authorizes the Town Council President, Dawn Lowden, the Town Manager, Ryan Cannon, and the Clerk-Treasurer, Julie Loker, to execute all documents necessary to purchase the Property and to take all other action necessary to close the transaction, in compliance with the purchase agreement; and

**Therefore, it is resolved**, that the Avon Town Council hereby authorizes and approves the execution of a purchase agreement with AVON MAP, LLC, authorizes the purchase of property and appurtenant structures and improvements from AVON MAP, LLC, and authorizes the Town Council President, Town Manager, and Clerk-Treasurer to take all other action necessary to comply with the purchase agreement and to otherwise close the transaction.

Resolved this 12th day of March, 2026.

**AVON TOWN COUNCIL:**

---

Dawn Lowden, President

---

Jayson Puckett, Vice President

---

William Holland, Member

---

Robert Pope, Member

---

Greg Zusan, Member

**Attest:**

---

Julie Loker, Clerk-Treasurer

**Exhibit A**  
Purchase Agreement

## REAL ESTATE PURCHASE AGREEMENT

THIS REAL ESTATE PURCHASE AGREEMENT (“**Agreement**”) is entered into and made effective as of the last date this Agreement is signed below (the “**Effective Date**”), by and between AVON MAP, LLC, an Indiana limited liability company (“**Seller**”), and TOWN OF AVON, INDIANA (“**Buyer**”).

**WHEREAS**, Seller is the owner of certain real estate and improvements located at 8217 Kingston Street, Avon, Hendricks County, Indiana 46123, as more particularly described herein, and is willing to sell all of such real estate and improvements to Buyer, and Buyer is willing to purchase all of such real estate and improvements from Seller, all upon the terms and conditions hereinafter set forth.

**NOW, THEREFORE**, in consideration of the mutual covenants and premises herein contained and for other good and valuable consideration, the receipt and sufficiency of which is hereby acknowledged, the parties hereto hereby agree as follows:

1. **DEFINITIONS.** The following defined terms used in this Agreement shall have the meanings specified below:

a. “**Closing**” means the consummation of the purchase and sale of the Property in accordance with the terms of this Agreement.

b. “**Closing Date**” means the date on which the Closing shall occur as provided in this Agreement.

c. “**Loan Policy**” means an ALTA mortgagee's title insurance policy issued by the Title Company insuring Seller's first lien mortgage position in the Property.

d. “**Owners Title Policy**” means a policy of title insurance issued by the Title Company insuring Buyer's interest in the Property.

e. “**Personal Property**” means all right, title, and interest of Seller, if any, in all tangible personal property located on and used in connection with the Property, including, without limitation all fixtures, fittings, appliances, tools, equipment, supplies, carpeting, machinery and other inventory.

f. “**Property**” means the approximately 2.14 acres of land located at 8217 Kingston Steet, Avon, Hendricks County, Indiana 46123, as depicted on **Exhibit A** attached hereto and made a part hereof. The Property expressly includes the one (1) building located thereon, together with all other improvements, tenements, hereditaments, privileges and appurtenances belonging or in any way pertaining thereto, including any right, title or interest of Seller in and to adjacent streets, alleys, or rights-of-way.

g. “**Title Company**” means Kensington Vanguard National Land Services (Indianapolis Office) (Tatiana McFadden).

h. “**Title Commitment**” means the title insurance commitment issued by the Title Company in which the Title Company commits itself to issue to Buyer the Owners Title Policy upon demand, with its general exceptions deleted, in the full amount of the Purchase Price (hereinafter defined), setting forth the state of the title to the Property and subject only to the Permitted Exceptions (defined below).

2. **PURCHASE AND SALE.** Buyer agrees to purchase and Seller agrees to sell, the Property, all upon the terms and subject to the conditions contained herein.

3. **PURCHASE PRICE / PAYMENT.**

a. **Price.** Buyer shall pay Seller an amount equal to \$1,452,500.00 (the “**Purchase Price**”).

b. **Payment Terms.** The Purchase Price shall be paid as follows:

i. **Earnest Money.** \$10,000.00 earnest money deposited with the Title Company in the time and manner set forth below (the “**Earnest Money**”).

ii. **Cash.** \$390,000.00 of the Purchase Price (subject to prorations and adjustments as provided herein) shall be payable in cash at Closing by wire transfer of immediately available funds to a bank account designated by Seller in writing to Buyer.

iii. **Seller Note.** Upon Closing, Buyer, as maker, shall execute a Promissory Note Secured by Mortgage in favor of Seller, as holder (the “**Note**”), in the amount of \$1,052,500.00 upon the following conditions and in the form attached hereto as **Exhibit B:**

a. The first payment due under the Note shall be due on or before July 1, 2027 (the “**First Payment Due Date**”) in the principal amount of \$526,250.00, plus accrued but unpaid interest due as of the First Payment Due Date. The remaining \$526,250.00 principal balance of the Note, plus all accrued but unpaid interest, shall be due and payable no earlier than January 1, 2028 and no later than the Maturity Date (as defined below).

b. The interest rate charged under the Note shall be a fixed rate per annum equal to 5.00%.

c. The maturity date will be January 5, 2028 (the “**Maturity Date**”), at which time all remaining outstanding principal and accrued interest shall be immediately due and payable.

d. In addition to the principal and interest payments due as set forth above, Buyer shall make quarterly interest payments to Seller during the term of the Note on each March 31<sup>st</sup>, June 30<sup>th</sup>, September 30<sup>th</sup> and December 31<sup>st</sup>, with the first such interest payment being due on March 31, 2026.

e. Buyer may not prepay all or any portion of the Note without Seller’s prior written consent.

f. The Note shall be secured by a mortgage (“**Mortgage**”) encumbering the Property in favor of Seller in the form attached hereto as **Exhibit C.**

c. **Deposit of Earnest Money.** Within five (5) business days after the Effective Date, Buyer shall deposit the Earnest Money with the Title Company. The Earnest Money will be fully credited towards the Purchase Price at Closing, provided that this Agreement is not terminated pursuant to the provisions hereof. The Title Company will act as escrow agent with respect to the Earnest Money and shall disburse the Earnest Money to the party entitled thereto under the terms of this Agreement.

4. **CLOSING, PAYMENT, CONVEYANCE AND POSSESSION.**

a. **Location.** The Closing shall occur at the offices of the Title Company, or at such other place as the parties may mutually agree. Seller and Buyer are not required to attend the Closing.

b. **Timing.** The Closing Date shall be on or before March 31, 2026, or such earlier or later date agreed upon in writing between Seller and Buyer. The exact Closing Date shall be determined by Seller and Buyer.

c. **Payment.** At the Closing, Buyer shall pay the Purchase Price in accordance with the terms contained in **Sections 3bii and 3biii** hereof.

d. **Conveyance.** At the Closing, Seller shall convey the Property to Buyer, subject to the lien of the Mortgage and Permitted Exceptions.

5. **DUE DILIGENCE.** Buyer has completed all of its due diligence and inspections of the Property prior to the Effective Date. Buyer therefore hereby waives any due diligence rights regarding the Property and agrees to accept the Property at Closing in its “as is, where is” condition, as more particularly described in **Section 10** below.

6. **TITLE TO PROPERTY.** Seller shall order a Title Commitment for the Property within five (5) business days of the Effective Date. Buyer may, but shall not be obligated to, obtain, at Buyer’s expense, an ALTA Survey of the Property (the “**Survey**”). Buyer shall have until ten (10) business days after Buyer receives the Title Commitment to advise Seller in writing that Buyer either (i) accepts the condition of title as stated in the Title Commitment or (ii) that Buyer objects to the condition of title because it does not allow Buyer to use the Property for Buyer’s intended use. If Buyer fails to timely elect either item (i) or (ii) above, then Buyer shall be deemed to have elected item (i) above. Seller shall have five (5) business days from the date such objections are disclosed to advise Buyer in writing the Seller will either: (x) cure the same; or (y) determine that it will not cure such objections. If Seller fails to timely elect either item (x) or (y) above, then Seller shall be deemed to have elected item (y) above. If the objections are not satisfied or cured within such time period, Buyer may within five (5) days after Seller’s failure (or deemed failure) to cure the objections, then Buyer may either (a) terminate this Agreement and the Title Company shall return the Earnest Money to Buyer, or (b) waive the unsatisfied objections and proceed to Closing. If Buyer fails to timely elect either item (a) or (b) above, then Buyer shall be deemed to have elected item (b) above. Any item to which no objection is made or waived within the aforementioned time periods shall thereafter be a “**Permitted Exception.**”

7. **CLOSING DELIVERIES.**

a. **Seller’s Deliveries.** At the Closing, Seller shall deliver to Buyer, the following:

i. **Title Policy.** An Owners Title Policy with an effective date as of the Closing Date in the amount of the Purchase Price paid at such Closing subject only to the

Permitted Exceptions.

ii. Deed. A duly executed and acknowledged Special Warranty Deed conveying good and marketable title to the Property to Buyer, subject only to the Mortgage and the Permitted Exceptions.

iii. Bill of Sale. A duly executed Bill of Sale conveying good and marketable title to the Personal Property, if any to Buyer.

iv. Vendor's Affidavit. A duly executed and acknowledged Vendor's Affidavit acceptable to the Title Company.

v. FIRPTA Certificate. A certification establishing that no federal income tax is required to be withheld under the Foreign Investment and Real Property Tax Act, or to consent to withholding of tax from the proceeds of sale as required.

vi. Sales Disclosure Form. A sales disclosure form required by the State of Indiana.

vii. Settlement Statement. A Closing settlement statement reflecting the financial provisions of the Closing, consistent with the provisions of this Agreement.

viii. Authority. Proper evidence of Seller's authority to enter into the any document required hereunder.

ix. Other. Any other documents reasonably required by the Title Company to close these transactions.

b. **Buyer's Deliveries**. At the Closing, Buyer shall deliver to Seller, the following:

i. Purchase Price; Note. The amount of the Purchase Price payable in such form as required herein, including without limitation the execution and delivery of the Note, subject to the closing adjustments and prorations provided herein.

ii. Mortgage. A duly executed Mortgage securing repayment of the debt evidenced by the Note.

iii. Loan Policy. The Loan Policy.

iv. Environmental Indemnity Agreement. A duly executed Environmental Indemnity Agreement in favor of Seller, as lender under the Note and Mortgage in form and content set forth on Exhibit D attached hereto.

v. Sales Disclosure Form. Buyer's countersignature to the Sales Disclosure Form.

vi. Settlement Statement. Buyer's countersignature to the Settlement Statement.

vii. Authority. Proper evidence of Buyer's authority to enter into the any document required hereunder.

viii. Other. Any other documents reasonably required to close these transactions.

c. **Form of Documentation.** All of the documents and instruments required to be delivered at Closing shall be in a form and manner reasonably satisfactory to Seller, Buyer and the Title Company, and each of their respective counsel.

8. **CLOSING COSTS, ADJUSTMENTS AND PRORATIONS.**

a. **Taxes and Assessments.** Seller shall pay all real estate taxes and assessments assessed against the Property (collectively, “**Taxes**”) due and payable in the calendar year prior to the Closing and all prior years. Seller and Buyer shall prorate, as of the Closing Date, on a per diem basis, all Taxes due and payable in the calendar year of the Closing and all installments of special assessments due and payable in the calendar year of the Closing. Buyer shall assume all levied, pending and/or deferred special assessments not due and payable in the calendar year of Closing. If the tax rate for taxes assessed in the current year has not been determined at the Closing of the transaction, said rate shall be assumed to be the same as the prior year for the purpose of such proration and credit for due but unpaid taxes and such proration shall be deemed final at the Closing.

b. **Insurance.** Seller shall maintain all property/casualty insurance on the Property through the Closing Date and Buyer shall provide insurance for the Property thereafter.

c. **Other Prorations.** Any ordinary operating expenses of the Property, including, but not limited to, public utility charges, shall be prorated as of the Closing Date.

d. **Proration Method.** Unless otherwise stated herein, Buyer’s and Seller’s respective proration obligations shall be determined as follows: (i) Seller pays that part of expenses (including Taxes) that have accrued before the Closing Date; (ii) Buyer pays that part of expenses (including Taxes) that accrue on or after the Closing Date; (iii) Seller is entitled to any income that has accrued before the Closing Date; and (iv) Buyer is entitled to any income that accrues on or after the Closing Date. All prorations appearing on the Settlement Statement shall be final and shall not survive Closing.

e. **Seller’s Closing Costs.** In addition to other costs stipulated to be paid by Seller under other provisions of this Agreement, Seller shall pay (i) the cost of the Owners Title Policy (including search and exam fees, but excluding any endorsements requested by Buyer), (ii) the cost of releasing Seller’s mortgage, if any; and (iii) one half (1/2) of the closing fee charged by the Title Company.

f. **Buyer’s Closing Costs.** In addition to the other costs stipulated to be paid by Buyer under other provisions of this Agreement, Buyer shall pay (i) all recording costs related to the conveyance of the Property to Buyer, (ii) the cost of the Survey, if obtained, (iii) the cost of the Loan Policy issued in favor of Seller, (iv) one half (1/2) of the closing fee charged by the Title Company, and (v) the costs of any required title endorsements to the Owner’s Policy requested by Buyer.

g. **Attorneys’ Fees.** Each of Seller and Buyer shall pay its own attorneys’ fees in connection with the preparation and negotiation of this Agreement and the Closing.

9. **RISK OF LOSS; CONDEMNATION.**

a. **Casualty.** If all or any portion of the Property is damaged or destroyed by any casualty after the Effective Date but prior to the Closing Date, Seller will have no obligation to repair or replace any damage or destruction caused by the foregoing, but Seller will assign the insurance proceeds to Purchaser. Notwithstanding the foregoing, if such casualty is a Material Event (defined below), then Buyer may elect to terminate this Agreement by written notice to Seller given on or before the Closing Date, and upon such termination, any Earnest Money will be returned to Buyer and the parties will have no further liability or obligation hereunder. As used in this Section, a "**Material Event**" means a casualty resulting in damage or destruction to the Property, if the cost to restore the Property to its condition immediately prior to such casualty is reasonably estimated to exceed \$100,000.00.

b. **Condemnation.** If, prior to the Closing Date, any governmental entity commences any eminent domain proceedings ("**Proceedings**") against all or any part of the Property, Seller shall promptly give notice to Buyer of such fact, and, at Buyer's option (to be exercised by notice to Seller and Title Company within 10 days after receipt of Seller's notice), this Agreement shall terminate, in which event Title Company shall return the Earnest Money to Buyer. Upon such return, neither Seller nor Buyer shall have any further rights or obligations under this Agreement, except for any obligations surviving the termination of this Agreement. If Buyer does not give such notice, then there shall be no reduction in the Purchase Price, and Seller shall assign to Buyer at the Closing Date all of Seller's right, title, and interest in and to any award made or to be made in the Proceedings.

10. **SELLER'S REPRESENTATIONS AND WARRANTIES.** To induce Buyer to enter into this Agreement, Seller represents and warrants to Buyer as follows:

a. **Title.** Seller has good and marketable and indefeasible title to the Property.

b. **Litigation.** To the best of Seller's knowledge, no action, suit, claim, arbitration, litigation or other proceedings is pending or threatened against the Property or any part thereof, except that certain lawsuit captioned Cameron Grimes as plaintiff and Remlles Enterprises LLC ("**Remlles**") and Seller as defendants pending in the Hendricks County, Indiana Superior Court 1 under Cause Number 32D01-2512-CT-000235. Such litigation has not resulted in any final adjudication or judgment against Seller.

c. **Rights of Third Parties.** To the best of Seller's knowledge, other than Remlles, a tenant at the Property, there are no persons in possession or occupancy of the Property or any part thereof, nor are there any persons who have possessory or other rights with respect to the Property or any part thereof. Notwithstanding the foregoing, Seller shall cause the lease with Remlles to be terminated prior to Closing. If the lease with Remlles is not terminated prior to Closing, or if Remlles has not vacated the Property prior to Closing, then either party may terminate this Agreement, in which case the Earnest Money shall be paid to Buyer and the parties shall have no further obligations to one another except those that specifically survive termination of this Agreement.

d. **Condemnation.** Seller has received no written notice, and Seller has no knowledge, that there are any pending or threatened, condemnation or similar proceedings affecting the Property or any part thereof.

e. **Anti-Terrorism.** Seller is not (A) listed on the Specially Designated Nationals

and Blocked Persons List maintained by the Office of Foreign Assets Control, Department of the Treasury, or (B) a person or entity with whom Buyer is prohibited from dealing or otherwise engaging in any transaction by any Anti-Terrorism Law, or (C) a person or entity that commits, threatens or conspires to commit or supports “terrorism” as defined or used in the Anti-Terrorism Laws. The “Anti-Terrorism Laws” are Executive Order No. 13224, 66 Fed. Reg. 49079 (published September 25, 2001) and the Uniting and Strengthening America by Providing Appropriate Tools to Intercept and Obstruct Terrorism Act of 2001, as amended.

f. **Authority.** Seller has the full right, title, power and authority to enter into this Agreement and to consummate a sale of the Property, and all persons whose signatures are necessary to purchase the Property have duly executed this Agreement.

Property Sold in “As Is” Condition. **Except as is otherwise expressly provided in this Agreement, Seller hereby specifically disclaims any warranty (oral or written) concerning: (i) the nature and condition of the Property and the suitability thereof for any and all activities and uses that Buyer elects to conduct thereon; (ii) the manner, construction, condition and state of repair or lack of repair of the Improvements; (iii) the compliance of the Property and the improvements thereon or their operation with any laws, rules, ordinances or regulations of any government or other body; and (iv) any other matter whatsoever except as expressly set forth in this Agreement.**

**EXCEPT AS IS OTHERWISE EXPRESSLY PROVIDED IN THIS AGREEMENT, THE SALE OF THE PROPERTY AS PROVIDED FOR HEREIN IS MADE ON A STRICTLY “AS IS” “WHERE IS” BASIS AS OF THE CLOSING DATE, AND SELLER MAKES NO WARRANTY OR REPRESENTATION, EXPRESS OR IMPLIED, OR ARISING BY OPERATION OF LAW, INCLUDING, BUT IN NO WAY LIMITED TO, ANY WARRANTY OF QUANTITY, QUALITY, CONDITION, HABITABILITY, MERCHANTABILITY, SUITABILITY OR FITNESS FOR A PARTICULAR PURPOSE OF THE PROPERTY, ANY IMPROVEMENTS LOCATED THEREON OR ANY SOIL OR OTHER CONDITIONS RELATED THERETO.**

**BUYER SPECIFICALLY ACKNOWLEDGES THAT BUYER IS NOT RELYING ON (AND SELLER HEREBY DISCLAIMS AND RENOUNCES) ANY REPRESENTATIONS OR WARRANTIES MADE BY OR ON BEHALF OF SELLER OF ANY KIND OR NATURE WHATSOEVER, EXCEPT FOR THOSE PARTICULAR REPRESENTATIONS AND WARRANTIES EXPRESSLY PROVIDED IN THIS AGREEMENT. FURTHER, AND WITH THE EXCEPTION OF CLAIMS BASED ON BREACH OF SELLER’S REPRESENTATIONS AND WARRANTIES IN THIS SECTION 10, BUYER, FOR BUYER AND BUYER’S SUCCESSORS AND ASSIGNS, HEREBY RELEASES SELLER FROM, AND WAIVES, ANY AND ALL CLAIMS AND LIABILITIES AGAINST SELLER FOR, RELATED TO, OR IN CONNECTION WITH, ANY ENVIRONMENTAL OR PHYSICAL CONDITION AT THE PROPERTY (OR THE PRESENCE OF ANY MATTER OR SUBSTANCE RELATING TO THE ENVIRONMENTAL CONDITION OF THE PROPERTY), INCLUDING, BUT NOT LIMITED TO, CLAIMS AND/OR LIABILITIES RELATING TO (IN ANY MANNER WHATSOEVER) ANY HAZARDOUS, TOXIC OR DANGEROUS MATERIALS OR SUBSTANCES, INCLUDING, BUT NOT LIMITED TO HEAVY METALS, OTHER TOXINS AND LEASE, LOCATED IN, AT, ABOUT OR UNDER THE PROPERTY, OR FOR ANY AND ALL CLAIMS OR CAUSES OF ACTION (ACTUAL OR THREATENED) BASED UPON, IN CONNECTION WITH, OR ARISING OUT OF, CERCLA, AS AMENDED BY SARA, AND AS MAY BE FURTHER AMENDED FROM TIME TO TIME, RCRA, OR ANY OTHER CLAIM OR CAUSE OF ACTION (INCLUDING ANY FEDERAL OR STATE BASED STATUTORY, REGULATORY OR COMMON LAW CAUSE OF ACTION) RELATED TO ENVIRONMENTAL MATTERS OR LIABILITY WITH RESPECT TO, OR AFFECTING, THE PROPERTY. BUYER REPRESENTS**

TO SELLER THAT BUYER HAS CONDUCTED, OR WILL CONDUCT PRIOR TO CLOSING, SUCH INVESTIGATIONS OF THE PROPERTY, INCLUDING BUT NOT LIMITED TO, THE PHYSICAL AND ENVIRONMENTAL CONDITIONS THEREOF, AS BUYER DEEMS NECESSARY TO SATISFY ITSELF AS TO THE CONDITION OF THE PROPERTY AND THE EXISTENCE OR NONEXISTENCE OF, OR CURATIVE ACTION TO BE TAKEN WITH RESPECT TO, ANY HAZARDOUS OR TOXIC SUBSTANCES ON OR DISCHARGED FROM THE LAND OR THE IMPROVEMENTS, AND WILL RELY SOLELY UPON SAME AND NOT UPON ANY INFORMATION PROVIDED BY, OR ON BEHALF OF, SELLER, ITS AGENTS AND EMPLOYEES WITH RESPECT THERETO, OTHER THAN SUCH REPRESENTATIONS AND WARRANTIES OF SELLER AS ARE EXPRESSLY SET FORTH IN THIS AGREEMENT. UPON CLOSING, BUYER SHALL ASSUME THE RISK THAT ADVERSE MATTERS, INCLUDING BUT NOT LIMITED TO, CONSTRUCTION DEFECTS AND ADVERSE PHYSICAL AND ENVIRONMENTAL CONDITIONS, MAY NOT HAVE BEEN REVEALED BY BUYER'S INVESTIGATIONS, AND BUYER, UPON CLOSING, SHALL BE DEEMED TO HAVE WAIVED, RELINQUISHED AND RELEASED SELLER FROM AND AGAINST ANY AND ALL CLAIMS, DEMANDS, CAUSES OF ACTION (INCLUDING CAUSES OF ACTION IN TORT), LOSSES, DAMAGES, LIABILITIES, COSTS AND EXPENSES (INCLUDING ATTORNEYS' FEES AND COURT COSTS) OF ANY AND EVERY KIND OR CHARACTER, KNOWN OR UNKNOWN, WHICH BUYER MIGHT HAVE ASSERTED OR ALLEGED AGAINST SELLER, AT ANY TIME BY REASON OF OR ARISING OUT OF ANY LATENT OR PATENT CONSTRUCTION DEFECTS OR PHYSICAL CONDITIONS, VIOLATIONS OF ANY APPLICABLE LAWS (INCLUDING, WITHOUT LIMITATION, ANY ENVIRONMENTAL LAWS) AND ANY AND ALL OTHER ACTS, OMISSIONS, EVENTS, CIRCUMSTANCES OR MATTERS REGARDING THE PROPERTY WITH THE EXCEPTION OF CLAIMS BASED ON BREACH OF SELLER'S EXPRESS REPRESENTATIONS AND WARRANTIES IN THIS SECTION 10.

BUYER ACKNOWLEDGES AND AGREES THAT THE WAIVERS, RELEASES AND OTHER PROVISIONS CONTAINED IN THIS SECTION 10 WERE A MATERIAL FACTOR IN SELLER'S ACCEPTANCE OF THE PURCHASE PRICE AND THAT SELLER IS UNWILLING TO SELL THE PROPERTY TO BUYER UNLESS SELLER IS RELEASED AS EXPRESSLY SET FORTH ABOVE. BUYER, WITH BUYER'S COUNSEL, HAS FULLY REVIEWED THE DISCLAIMERS AND WAIVERS SET FORTH IN THIS AGREEMENT, AND UNDERSTANDS THE SIGNIFICANCE AND EFFECT THEREOF. THE TERMS AND CONDITIONS OF THIS SECTION 10 WILL EXPRESSLY SURVIVE THE CLOSING, WILL NOT MERGE WITH THE PROVISIONS OF ANY CLOSING DOCUMENTS, AND WILL BE INCORPORATED INTO THE DEED.

11. BUYER'S REPRESENTATIONS AND WARRANTIES. To induce Seller to enter into this Agreement, Buyer represents and warrants to Seller as follows:

a. **Authority**. Buyer has the full right, title, power and authority to enter into this Agreement and to consummate a purchase of the Property, and all persons whose signatures are necessary to purchase the Property have duly executed this Agreement.

Each of the foregoing representations and warranties shall be and remain true at and as of each Closing Date.

12. **OPERATION PRIOR TO CLOSING**. During the period from the Effective Date through the Closing Date (the "**Executory Period**"), except for the termination of the lease with Remlles, Seller shall operate and maintain the Property in the ordinary course of business in accordance with prudent, reasonable business standards, including but without limitation, the maintenance of adequate liability

insurance. During the Executory Period, Seller shall not execute any contracts, or other agreements regarding the Property or any part thereof, nor shall Seller cause or permit title to the Property to be encumbered or impaired, without the prior written consent of Buyer, which consent may be withheld by Buyer in its sole discretion. Buyer shall assume responsibility, at Closing, with respect to all agreements regarding the Property or any part thereof entered into during the Executory Period and to which Buyer has given its consent.

13. **BROKERS AND OTHER FEES AND EXPENSES.** Seller and Buyer represent and warrant to each other that neither party has employed, used the services of or otherwise dealt with any brokers, finders or the like in connection with this transaction. Each party shall indemnify and hold the other party harmless against all claims, damages, costs, or expenses of or for any other such fees or commissions resulting from their actions or agreements regarding the execution or performance of this Agreement, and shall pay all costs of defending any legal action brought against the other party to recover any other such fees or commissions, including reasonable attorneys' fees.

14. **DEFAULT.** If any party breaches any provision of this Agreement, the non-breaching party shall give such breaching party written notice of same and ten (10) days opportunity to cure such breach. If any breach remains uncured thereafter, such breaching party shall be in "**Default**" of this Agreement.

15. **REMEDIES UPON DEFAULT.** If Buyer defaults in the performance of the Agreement, then Seller may retain the Earnest Money, as liquidated damages, as its sole and exclusive remedy, it being agreed that actual damages are difficult, if not impossible, to ascertain. If Seller defaults in the performance of the Agreement, then Buyer may as its sole and exclusive remedy elect either to: (i) terminate this Agreement in which case the Earnest Money shall be returned immediately to Buyer by Title Company; or (ii) bring an action against Seller for specific performance provided that such action is commenced within sixty (60) days of the event or condition giving rise to such action. In no event shall Seller be deemed to be in default of this Agreement if as of the Closing Date the lease with Remlles is not terminated, or Remlles has not vacated the Property, however, in any such event, either party may terminate this Agreement and the Earnest Money shall be paid to Buyer.

16. **NOTICES.** All notices, elections, requests and other communications hereunder shall be in writing and shall be deemed sufficiently given when delivered via electronic mail (with evidence of successful transmission or receipt) and delivered to the individuals at the email addresses below (or to such other person, or to such other address, of which any party hereto shall have given written notice as provided herein):

If to Buyer:

If to Seller:

Marc Freije (paulmar123@aol.com)  
with a copy to Steven Glazier (sglazier@cgglawfirm.com)

Either party's counsel may deliver notices on behalf of Seller or Buyer.

17. **TITLE COMPANY AS ESCROW AGENT.** Title Company shall hold and disburse the Earnest Money as provided in this Agreement. Upon receipt of any written certification from Seller or Buyer claiming the Earnest Money, Title Company shall promptly forward a copy thereof to the other party hereto and, unless such party within 5 business days thereafter objects by written notice to Title Company to such disbursement, Title Company shall disburse the Earnest Money to the party demanding the same and shall thereupon be released and discharged from any duty or obligation hereunder. Title Company is acting as escrow agent only with respect to the Earnest Money, to the extent deposited by Buyer, and if there is any dispute as to whether Title Company is obligated to deliver the Earnest Money, or as to whom

the Earnest Money is to be delivered, Title Company may refuse to make delivery and may continue to hold the Earnest Money until receipt by Title Company of an authorization, in writing, signed by Seller and Buyer, directing the disposition of the Earnest Money; in the absence of such written authorization, Title Company may hold the Earnest Money until a final determination of the rights of the parties by appropriate proceeding or may bring an appropriate action or proceeding for leave to deposit the Earnest Money in a court of competent jurisdiction pending such determination. Seller and Buyer recognize that Title Company's duties hereunder are only as specifically provided herein and are purely ministerial in nature; and Seller and Buyer therefore agree that Title Company shall, so long as it acts in good faith and in accordance with this Agreement, have no liability to either Buyer or Seller, except for its willful misconduct or gross negligence. Seller and Buyer do hereby further indemnify Title Company against, and agree to hold, save and defend Title Company harmless from, any costs, liabilities and expenses incurred by Title Company in discharging its duties hereunder, except for willful misconduct or gross negligence.

18. **MISCELLANEOUS.**

a. **Agreement Binding.** This Agreement shall be binding upon and shall inure to the benefit of Seller and Buyer and their respective heirs, successors and assigns.

b. **Headings and Captions.** The several headings and captions of the Sections and Subsections used herein are for convenience or reference only and shall, in no way, be deemed to limit, define or restrict the substantive provisions of this Agreement.

c. **Entire Agreement.** This Agreement constitutes the entire agreement of Buyer and Seller with respect to the purchase and sale of the Property superseding any prior or contemporaneous agreement with respect thereto. No amendment or modification of this Agreement shall be binding upon the parties unless made in writing and signed by both Seller and Buyer.

d. **Litigation.** In the event of any litigation arising out of this Agreement, the prevailing party shall be entitled to reasonable attorneys' fees and costs, which shall be in addition to any liquidated damages provided for herein.

e. **No Partnership.** Nothing contained in this Agreement shall be construed to create a partnership or joint venture between the parties or their successors in interest.

f. **Time of the Essence.** Time is of the essence in this Agreement.

g. **Memorandum of Agreement.** Neither party shall execute or record a memorandum of this Agreement or any other document in any office or place of public record.

h. **Survival.** Except as otherwise expressly provided for herein, all warranties, representations, covenants, obligations and agreements of Seller and buyer contained in this Agreement shall terminate on the Closing.

i. **Business Days.** As used in this Agreement, "business days" shall mean a day in which federally insured national banking associations located in the county in which the Property is situated are not closed.

j. **Governing Law.** This Agreement and the rights of the parties hereunder shall be governed by and construed in accordance with the laws of the State of Indiana.

k. **Assignability.** Upon prior written notice, Buyer may assign Buyer's rights hereunder at or immediately prior to Closing without Seller's consent to any affiliate or non-affiliate of Buyer. Buyer shall provide Seller with a copy of the fully-executed assignment and assumption agreement prior to Closing.

l. **Counterparts.** This Agreement may be executed in any number of identical counterparts, any or all of which may contain the signatures of less than all of the parties, and all of which shall be construed together as but a single instrument. Signatures to this Agreement transmitted by electronic mail (including signatures transmitted via PDF or DocuSign) shall be valid and effective to bind the parties so signing and transmitting.

*(signature page follows)*

**SIGNATURE PAGE TO REAL ESTATE PURCHASE AGREEMENT**

IN WITNESS WHEREOF, the parties hereto have executed this Agreement effective as of the Effective Date.

**SELLER:**

AVON MAP, LLC, an Indiana limited liability company

By: \_\_\_\_\_

Printed Name: \_\_\_\_\_

Title: \_\_\_\_\_

Date: \_\_\_\_\_

**BUYER:**

TOWN OF AVON, INDIANA

By: \_\_\_\_\_

Printed Name: \_\_\_\_\_

Title: \_\_\_\_\_

Date: \_\_\_\_\_

**TITLE COMPANY SIGNATURE PAGE  
TO REAL ESTATE PURCHASE AGREEMENT**

**TITLE COMPANY:**

(For the purpose of acknowledging its agreement with the provisions hereof relating to its duties and obligations as escrow agent hereunder, including without limitation **Section 17**)

Kensington Vanguard National Land Services

By: \_\_\_\_\_

Name: \_\_\_\_\_

Title: \_\_\_\_\_

**Exhibit A**  
**Depiction of Property**



**Exhibit B**

**Form of Promissory Note Secured by Mortgage**

**Note Date:** \_\_\_\_\_, 2026  
**Maturity Date:** January 5, 2028

**PROMISSORY NOTE SECURED BY MORTGAGE**

For value received on the Note Date, the undersigned, TOWN OF AVON, INDIANA (the "Borrower"), promises to pay to AVON MAY, LLC, an Indiana limited liability company (the "Lender"), at 1345C Brookville Way, Indianapolis, Indiana 46239 or such other place as Lender may from time to time designate, the principal sum of \$1,052,500.00, all without relief from valuation and appraisal law, under the following terms:

1. Statement of the Transaction. Lender is lending the principal amount of this Promissory Note Secured by Mortgage (the "Note") as part of Borrower's purchase of certain property located at 8217 Kingston Street, Avon, Hendricks County, Indiana 46213, together with all improvements thereon ("Property"), pursuant to the terms and conditions contained in that certain Real Estate Purchase Agreement dated \_\_\_\_\_, 2026 between Lender, as seller, and Borrower, as buyer (the "Purchase Agreement").

2. Interest Rate. The interest rate charged under the Note shall be a fixed rate per annum equal to 5.00%.

3. Default Rate. In the event of a default under this Note, Lender may, in its sole discretion, determine that all amounts owing to Lender shall bear interest at a rate of ten and 00/100 percent (10.0%) per annum until such default has been cured in accordance with the terms of this Note.

4. Payments. Borrower shall pay the outstanding balance under this Note as follows:

a. On or before July 1, 2027 (the "First Payment Due Date"), Borrower shall pay Lender \$526,250.00, plus accrued but unpaid interest due as of the First Payment Due Date.

b. The remaining \$526,250.00 balance of the Note, plus all accrued but unpaid interest, shall be due and payable no earlier than January 1, 2028 and no later than the Maturity Date (as defined below).

c. In addition to the principal and interest payments due as set forth above, Borrower shall make quarterly interest payments to Lender during the term of the Note on each March 31<sup>st</sup>, June 30<sup>th</sup>, September 30<sup>th</sup> and December 31<sup>st</sup>, with the first such interest payment being due on March 31, 2026.

d. Borrower shall pay Lender the entire amount of outstanding principal and accrued interest due under this Note upon the Maturity Date.

e. Borrower may not prepay all or any portion of the Note without Lender's prior written consent.

5. Mortgage. This Note shall be secured by a mortgage encumbering the Property (“Mortgage”) and is agreed by the parties hereto that Borrower shall not assign or otherwise transfer any right, title or interest in or to the Property or the Mortgage during the term of this Note, without the written consent of Lender to such assignment or transfer, which consent may be withheld by Lender in Lender’s sole and absolute discretion.

6. Late Payment Charge. If a payment is more than ten (10) days late, Lender may charge a late payment charge of five percent (5%) of any amount due.

7. Events of Default. Borrower will be in default under this Note upon the occurrence of any of the following:

a. Borrower fails to make a payment on this Note to Lender within five (5) business days of when such payment is due.

b. Borrower permits the entry or service of any garnishment, judgment, tax levy, attachment or lien against the Property.

c. Borrower assigns or transfers the Property or the Mortgage without Lender’s written consent.

d. Borrower, as mortgagor under the Mortgage, defaults on any obligations under the Mortgage.

8. Borrower's Right to Cure. Failure to comply with any term, obligation, covenant or condition contained in this Note, other than the payment obligations described in this Note, shall become an event of default only after Borrower has been given a written notice of the breach and demand that such breach is corrected; and Borrower subsequently fails to cure such breach within fifteen (15) days of the delivery of such that notice. Borrower’s failure to make any payments when due hereunder shall constitute an event of default without any cure period.

9. Lender's Remedies. If there is a default under this Note, Lender will be entitled to exercise one or more of the following remedies without notice or demand (except as required by law):

a. To declare the outstanding principal amount, plus accrued interest under this Note, and all other present and future obligations of Borrower to Lender, to be immediately due and payable in full.

b. To exercise any other rights and remedies Lender may have against Borrower at law or in equity, including without limitation foreclosing upon the Mortgage.

Lender's rights are cumulative and may be exercised together, separately, and in any order.

10. Costs and Expenses. Borrower shall pay or reimburse Lender for all reasonable out-of-pocket costs and expenses, including but not limited to, reasonable attorney fees and legal expenses, incurred by Lender in connection with the enforcement of this Note.

11. Failure of Indulgence Not Waiver. No delay or omission on the part of Lender in the exercise of any right or remedy shall operate as a waiver of that right or remedy. No single or partial exercise by Lender

of any right or remedy shall preclude other or further exercise of that right or remedy or of any other right or remedy.

12. Notices, Waiver of Notice. All notices, elections, requests and other communications hereunder shall be in writing and shall be deemed sufficiently given if delivered to the parties in the manner and at the addresses contained in the Purchase Agreement. Either party's counsel may deliver notices on behalf of Lender or Borrower.

13. Assignability. Neither this Note nor any of the rights, benefits, or liabilities or obligations under this Note shall be assignable by Borrower without the prior written consent of Lender, which consent may be withheld by Lender in Lender's sole and absolute discretion.

14. Renewal or Extension. In case of renewal or extension of this Note, at any or all times, all of the provisions of the Mortgage shall remain in full force and effect as security for the payment of the renewed or extended Note and for the performance of the obligations of Borrower under this Note.

15. Headings. The descriptive headings in this Note are inserted for convenience only and should not constitute a part of, nor affect the meaning or interpretation of this Note or any section of this Note.

16. Governing Law. This Note shall be governed in all respects by the laws of the State of Indiana. The parties agree that any suit, action, or proceeding with respect to this Note shall be brought within Hendricks County, Indiana or Marion County, Indiana (as designated by Lender) and the parties do waive any questions of personal jurisdiction or venue for the purpose of carrying out this provision.

17. JURY WAIVER. BORROWER AND LENDER (BY ITS ACCEPTANCE HEREOF) HEREBY VOLUNTARILY, KNOWINGLY, IRREVOCABLY AND UNCONDITIONALLY WAIVE ANY RIGHT TO HAVE A JURY PARTICIPATE IN RESOLVING ANY DISPUTE (WHETHER BASED UPON CONTRACT, TORT OR OTHERWISE) BETWEEN OR AMONG BORROWER AND LENDER ARISING OUT OF OR IN ANY WAY RELATED TO THIS NOTE OR ANY OTHER LOAN DOCUMENT. THIS PROVISION IS A MATERIAL INDUCEMENT TO LENDER TO PROVIDE THE FINANCING DESCRIBED HEREIN.

18. Successors. This Note and all rights and obligations under this Note shall be binding upon and inured to the benefit of the parties to this Note and their respective successors and permitted assigns.

19. Severability. If any provision of this Note is held invalid or unenforceable by any court of competent jurisdiction the other provisions of this Note will remain in full force and effect. Any provision of this Note held invalid or unenforceable only in part or degree will remain in full force and effect to the extent not held invalid or unenforceable.

*(signature page follows)*

**SIGNATURE PAGE OF BORROWER TO  
PROMISSORY NOTE SECURED BY MORTGAGE**

Executed as of the Note Date.

**BORROWER:**

TOWN OF AVON, INDIANA

By: Exhibit Only; No Signature  
Required Until Closing

Printed Name: \_\_\_\_\_

Title: \_\_\_\_\_

## Exhibit C

### Form of Mortgage

#### REAL ESTATE MORTGAGE, SECURITY AGREEMENT AND FIXTURE FILING

THIS REAL ESTATE MORTGAGE, SECURITY AGREEMENT AND FIXTURE FILING ("Mortgage") is made as of the \_\_ day of \_\_\_\_\_, 2026, by TOWN OF AVON, INDIANA ("Mortgagor"), to and for the benefit of AVON MAP, LLC, an Indiana limited liability company, its successors and assigns ("Mortgagee"):

#### RECITALS:

(A) Mortgagee has agreed to loan to Mortgagor the aggregate principal amount of One Million Fifty Two Thousand and 00/100 Dollars (\$1,052,000.00) ("Loan"). The Loan shall be evidenced by a certain Promissory Note of even date herewith (as amended, restated or replaced from time to time, collectively the "Note") made by Mortgagor payable to Mortgagee in the principal amount of the Loan and due on January 5, 2028 (the "Maturity Date"), except as may be accelerated pursuant to the terms hereof or of the Note or any other loan document ("Loan Documents").

(B) A condition precedent to Mortgagee's extension of the Loan to Mortgagor is the execution and delivery by Mortgagor of this Mortgage.

NOW, THEREFORE, for good and valuable consideration, the receipt and sufficiency of which are hereby acknowledged, Mortgagor agrees as follows:

Mortgagor hereby mortgages, grants, assigns, remises, releases, warrants and conveys to Mortgagee, its successors and assigns, and grants a security interest in, the following described property, rights and interests (referred to collectively herein as "Premises"), all of which property, rights and interests are hereby pledged primarily and on a parity with the Real Estate (as defined below) and not secondarily:

THE REAL ESTATE located in the City of Avon, County of Hendricks, State of Indiana and legally described on Exhibit A attached hereto and made a part hereof ("Real Estate"), commonly known as 8217 Kingston Street, Avon, Hendricks, Indiana 46123;

TOGETHER WITH all improvements of every nature whatsoever now or hereafter situated on the Real Estate, and all fixtures and personal property of every nature whatsoever now or hereafter owned by Mortgagor and on, or used in connection with the Real Estate or the improvements thereon, or in connection with any construction thereon, including all extensions, additions, improvements, betterments, renewals, substitutions and replacements to any of the foregoing and all of the right, title and interest of Mortgagor in and to any such personal property or fixtures together with the benefit of any deposits or payments now or hereafter made on such personal property or fixtures by Mortgagor or on its behalf ("Improvements");

TOGETHER WITH all easements, rights of way, gores of real estate, streets, ways, alleys, passages, sewer rights, waters, water courses, water rights and powers, and all estates, rights, titles, interests, privileges, liberties, tenements, hereditaments and appurtenances whatsoever, in any way now or hereafter belonging, relating or appertaining to the Real Estate, and the reversions, remainders, rents, issues and profits thereof, and all the estate, right, title, interest, property, possession, claim and demand whatsoever, at law as well as in equity, of Mortgagor of, in and to the same;

TOGETHER WITH all rents, revenues, issues, profits, proceeds, income, royalties, "accounts," including "health-care-insurance receivables," escrows, letter-of-credit rights (each as defined in the Code hereinafter defined), security deposits, impounds, reserves, tax refunds and other rights to monies from the Premises and/or the businesses and operations conducted by Mortgagor thereon, to be applied against the Indebtedness (hereinafter defined); provided, however, that Mortgagor, so long as no Event of Default (as hereinafter defined) has occurred hereunder, may collect rent as it becomes due, but not more than one (1) month in advance thereof;

TOGETHER WITH all interest of Mortgagor in all leases now or hereafter on the Premises, whether written or oral ("Leases"), together with all security therefor and all monies payable thereunder, subject, however, to the conditional permission hereinabove given to Mortgagor to collect the rentals under any such Lease;

TOGETHER WITH all proceeds of the foregoing, including, without limitation, all judgments, awards of damages and settlements hereafter made resulting from condemnation proceeds or the taking of the Premises or any portion thereof under the power of eminent domain, any proceeds of any policies of insurance, maintained with respect to the Premises or proceeds of any sale, option or contract to sell the Premises or any portion thereof.

TO HAVE AND TO HOLD the Premises, unto Mortgagee, its successors and assigns, forever, for the purposes and upon the uses herein set forth together with all right to possession of the Premises after the occurrence of any Event of Default; Mortgagee hereby RELEASING AND WAIVING all rights under and by virtue of the homestead exemption laws of the State of Indiana.

FOR THE PURPOSE OF SECURING: (i) the payment of the Loan and all interest, late charges, prepayment premium (if any), reimbursement obligations, and other indebtedness evidenced by or owing under the Note, any of the other Loan Documents, together with any extensions, modifications, renewals or refinancings of any of the foregoing; (ii) the performance and observance of the covenants, conditions, agreements, representations, warranties and other liabilities and obligations of Mortgagor or any other obligor to or benefiting Mortgagee which are evidenced or secured by or otherwise provided in the Note, this Mortgage or any of the other Loan Documents; (iii) the reimbursement to Mortgagee of any and all sums incurred, expended or advanced by Mortgagee pursuant to any term or provision of or constituting additional indebtedness under or secured by this Mortgage, any of the other Loan Documents, with interest thereon as provided herein or therein (collectively, "Indebtedness").

IT IS FURTHER UNDERSTOOD AND AGREED THAT:

1. Title. Mortgagor represents, warrants and covenants that (a) Mortgagor is the holder of the fee simple title to the Premises, free and clear of all liens and encumbrances, except those liens and encumbrances in favor of Mortgagee and as otherwise described on Exhibit B attached hereto ("Permitted Exceptions"); and (b) Mortgagor has legal power and authority to mortgage and convey the Premises.

2. Maintenance, Repair, Restoration, Prior Liens, Parking. Mortgagor covenants that, so long as any portion of the Indebtedness remains unpaid, Mortgagor will:

a. promptly repair, restore or rebuild any Improvements now or hereafter on the Premises which may become damaged or be destroyed to a condition substantially similar to the condition immediately prior to such damage or destruction, whether or not proceeds of insurance are available or sufficient for the purpose;

b. keep the Premises in good condition and repair, without waste, and free from mechanics', materialmen's or like liens or claims or other liens or claims for lien (subject to Mortgagor's right to contest liens as permitted by the terms of Paragraph 27 hereof);

c. pay when due the Indebtedness in accordance with the terms of the Note and the other Loan Documents and duly perform and observe all of the terms, covenants and conditions to be observed and performed by Mortgagor under the Note, this Mortgage and the other Loan Documents;

d. pay when due any indebtedness which may be secured by a permitted lien or charge on the Premises on a parity with, superior to or inferior to the lien hereof, and upon request exhibit satisfactory evidence of the discharge of such lien to Mortgagee (subject to Mortgagor's right to contest liens as permitted by the terms of Paragraph 27 hereof);

e. complete within a reasonable time any Improvements now or at any time in the process of erection upon the Premises;

f. comply with all requirements of law, municipal ordinances or restrictions and covenants of record with respect to the Premises and the use thereof;

g. obtain and maintain in full force and effect, and abide by and satisfy the material terms and conditions of, all material permits, licenses, registrations and other authorizations with or granted by any governmental authorities that may be required from time to time with respect to the performance of its obligations under this Mortgage;

h. make no material alterations in the Premises beyond the current project or demolish any portion of the Premises without Mortgagee's prior written consent, except as required by law or municipal ordinance;

i. suffer or permit no change in the use or general nature of the occupancy of the Premises, without Mortgagee's prior written consent;

j. pay when due all operating costs of the Premises;

k. not initiate or acquiesce in any zoning reclassification with respect to the Premises, without Mortgagee's prior written consent;

l. provide and thereafter maintain adequate parking areas within the Premises as may be required by law, ordinance or regulation (whichever may be greater), together with any sidewalks, aisles, streets, driveways and sidewalk cuts and sufficient paved areas for ingress, egress and right of way to and from the adjacent public thoroughfares necessary or desirable for the use thereof; and

m. cause the Premises at all times to be operated in compliance with all federal, state, local and municipal environmental, health and safety laws, statutes, ordinances, rules and regulations.

3. Payment of Taxes and Assessments. Mortgagor will pay when due and before any penalty attaches, all general and special taxes, assessments, water charges, sewer charges, and other fees, taxes, charges and assessments of every kind and nature whatsoever (all herein generally called "Taxes"), whether or not assessed against Mortgagor, if applicable to the Premises or any interest therein, or the Indebtedness, or any obligation or agreement secured hereby, subject to Mortgagor's right to contest the same, as provided

by the terms hereof; and Mortgagor will, upon written request, furnish to Mortgagee duplicate receipts therefor within ten (10) days after Mortgagee's request.

4. Tax Deposits. Upon an Event of Default, Mortgagor shall deposit with Mortgagee, on the first day of each month until the Indebtedness is fully paid, a sum equal to one twelfth (1/12th) of 105% of the most recent ascertainable annual Taxes on the Premises. If requested by Mortgagee, Mortgagor shall also deposit with Mortgagee an amount of money which, together with the aggregate of the monthly deposits to be made pursuant to the preceding sentence as of one month prior to the date on which the next installment of annual Taxes for the current calendar year become due, shall be sufficient to pay in full such installment of annual Taxes, as estimated by Mortgagee. Such deposits are to be held without any allowance of interest and are to be used for the payment of Taxes next due and payable when they become due. So long as no Event of Default shall continue to exist, Mortgagee shall, at its option, pay such Taxes when the same become due and payable (upon submission of appropriate bills therefor from Mortgagor) or shall release sufficient funds to Mortgagor for the payment thereof. If the funds so deposited are insufficient to pay any such Taxes for any year (or installments thereof, as applicable) when the same shall become due and payable, Mortgagor shall, within ten (10) days after receipt of written demand therefor, deposit additional funds as may be necessary to pay such Taxes in full. If the funds so deposited exceed the amount required to pay such Taxes for any year, the excess shall be applied toward subsequent deposits. Said deposits need not be kept separate and apart from any other funds of Mortgagee. Mortgagee, in making any payment hereby authorized relating to Taxes, may do so according to any bill, statement or estimate procured from the appropriate public office without inquiry into the accuracy of such bill, statement or estimate or into the validity of any tax, assessment, sale, forfeiture, tax lien or title or claim thereof.

5. Mortgagee's Interest In and Use of Deposits. Upon an Event of Default, Mortgagee may, at its option, apply any monies at the time on deposit pursuant to Paragraph 4 hereof to cure an Event of Default or to pay any of the Indebtedness in such order and manner as Mortgagee may elect. If such deposits are used to cure an Event of Default or pay any of the Indebtedness, Mortgagor shall immediately, upon demand by Mortgagee, deposit with Mortgagee an amount equal to the amount expended by Mortgagor from the deposits. When the Indebtedness has been fully paid, any remaining deposits shall be returned to Mortgagor. Such deposits are hereby pledged as additional security for the Indebtedness and shall not be subject to the direction or control of Mortgagor. Mortgagee shall not be liable for any failure to apply to the payment of Taxes any amount so deposited unless Mortgagor, prior to an Event of Default, shall have requested Mortgagee in writing to make application of such funds to the payment of such amounts, accompanied by the bills for such Taxes. Mortgagee shall not be liable for any act or omission taken in good faith or pursuant to the instruction of any party.

6. Insurance.

a. Mortgagor shall at all times keep all buildings, improvements, fixtures and articles of personal property now or hereafter situated on the Premises insured against loss or damage by fire and such other hazards as may reasonably be required by Mortgagee, in accordance with the terms, coverages and provisions required by Mortgagee, but in no event less than full replacement value. Unless Mortgagor provides Mortgagee evidence of the insurance coverages required hereunder, Mortgagee may purchase insurance at Mortgagor's expense to cover Mortgagee's interest in the Premises. The insurance may, but need not, protect Mortgagor's interest. The coverages that Mortgagee purchases may not pay any claim that Mortgagor makes or any claim that is made against Mortgagor in connection with the Premises. Mortgagor may later cancel any insurance purchased by Mortgagee, but only after providing Mortgagee with evidence that Mortgagor has obtained insurance as required by this Mortgage. If Mortgagee purchases insurance for the Premises, Mortgagor will be responsible for the costs of such insurance, including, without limitation, interest and any other charges which Mortgagee may impose in connection with the placement

of the insurance, until the effective date of the cancellation or expiration of the insurance. The costs of the insurance may be added to the Indebtedness. The cost of the insurance may be more than the cost of insurance Mortgageor may be able to obtain on its own.

b. Mortgageor shall at all times keep comprehensive public liability insurance on an "occurrence basis" against claims for "personal injury" including, without limitation, bodily injury, death or property damage occurring on, in or about the Mortgaged Property and the adjoining streets, sidewalks and passageways, such insurance to afford immediate minimum protection to a limit of not less than that Two Million and 00/100 Dollars (\$2,000,000.00) single limits or such other amounts required by Mortgagee with respect to personal injury or death to any one or more persons or damage to property;

c. Mortgageor shall not take out separate insurance concurrent in form or contributing in the event of loss with that required to be maintained hereunder unless Mortgagee is included thereon as the loss payee or an additional insured as applicable, under a standard mortgage clause acceptable to Mortgagee and such separate insurance is otherwise acceptable to Mortgagee.

d. In the event of loss, Mortgageor shall give prompt notice thereof to Mortgagee, who shall have the sole and absolute right to make proof of loss. Mortgagee shall have the right, at its option and in its sole discretion, to apply any insurance proceeds received by Mortgagee pursuant to the terms of this paragraph, after the payment of all of Mortgagee's expenses, either (i) on account of the Indebtedness, irrespective of whether such principal balance is then due and payable, whereupon Mortgagee may declare the whole of the balance of Indebtedness to be due and payable, or (ii) to the restoration or repair of the property damaged as provided in subparagraph d below; provided, however, Mortgagee agrees to permit the application of such proceeds to the restoration or repair of the damaged property, subject to the provisions of subparagraph d below, if the following are satisfied (i) Mortgagee has received satisfactory evidence that such restoration or repair shall be completed no later than the date that is six (6) months prior to the Maturity Date, (ii) no Event of Default, or event that with the passage of time, the giving of notice or both would constitute an Event of Default, then exists, and (iii) the Premises, after such restoration, will be at least leased so as to provide a debt service coverage ratio of at least 1.25:1; (vi) Borrower provides builder's all risk insurance for such restoration in form and amount acceptable to Lender; and (v) the insurer under such policies of fire or other casualty insurance does not assert any defense to payment under such policies against Lender, Borrower or any tenant of the Premises. If insurance proceeds are made available to Mortgageor by Mortgagee as hereinafter provided, Mortgageor shall repair, restore or rebuild the damaged or destroyed portion of the Premises so that the condition and value of the Premises are substantially the same as the condition and value of the Premises prior to being damaged or destroyed. In the event of foreclosure of this Mortgage, all right, title and interest of Mortgageor in and to any insurance policies then in force shall pass to the purchaser at the foreclosure sale.

e. If insurance proceeds are made available by Mortgagee to Mortgageor, Mortgageor shall comply with the following conditions:

i. Before commencing to repair, restore or rebuild following damage to, or destruction of, all or a portion of the Premises, whether by fire or other casualty, Mortgageor shall obtain from Mortgagee its approval of all site and building plans and specifications pertaining to such repair, restoration or rebuilding.

ii. Prior to each payment or application of any insurance proceeds to the repair or restoration of the improvements upon the Premises to the extent permitted in subparagraph c above (which payment or application may be made, at Mortgagee's option, through an escrow, the terms and conditions of which are satisfactory to Mortgagee and the cost of which is to be borne by Mortgageor), Mortgagee shall be satisfied as to the following:

(a) no Event of Default or any event which, with the passage of time or giving of notice would constitute an Event of Default, has occurred;

(b) either such Improvements have been fully restored, or the expenditure of money as may be received from such insurance proceeds will be sufficient to repair, restore or rebuild the Premises, free and clear of all liens, claims and encumbrances, except the lien of this Mortgage and the Permitted Exceptions, or, if such insurance proceeds shall be insufficient to repair, restore and rebuild the Premises, Mortgagor has deposited with Mortgagee such amount of money which, together with the insurance proceeds shall be sufficient to restore, repair and rebuild the Premises; and

(c) prior to each disbursement of any such proceeds, Mortgagee shall be furnished with a statement of Mortgagee's architect (the cost of which shall be borne by Mortgagor), certifying the extent of the repair and restoration completed to the date thereof, and that such repairs, restoration, and rebuilding have been performed to date in conformity with the plans and specifications approved by Mortgagee and with all statutes, regulations or ordinances (including building and zoning ordinances) affecting the Premises; and Mortgagee shall be furnished with appropriate evidence of payment for labor or materials furnished to the Premises, and total or partial lien waivers substantiating such payments.

iii. If Mortgagor shall fail to restore, repair or rebuild the Improvements within a time deemed satisfactory by Mortgagee, then Mortgagee, at its option, may (a) commence and perform all necessary acts to restore, repair or rebuild the said Improvements for or on behalf of Mortgagor, or (b) declare an Event of Default. If insurance proceeds shall exceed the amount necessary to complete the repair, restoration or rebuilding of the Improvements, such excess shall be applied on account of the Indebtedness irrespective of whether such Indebtedness is then due and payable without payment of any premium or penalty.

iv. Lender shall be entitled to require and to impose such other conditions to the release of such insurance proceeds for restoration of the Premises as would be customarily or reasonably required and imposed by a construction lender for a project of similar nature and cost. Provided, however, in case of Borrower's failure to keep the Premises so insured, Lender or its assigns, may, at its option (but shall not be required to) effect such insurance at Borrower's expense.

f. All policies of insurance required by the terms of this Mortgage shall contain a standard mortgagee clause and an endorsement or agreement by the insurer that any loss shall be payable in accordance with the terms of such policy notwithstanding any act or negligence of Mortgagor which might otherwise result in forfeiture of said insurance and the further agreement of the insurer waiving all rights of set off, counterclaim or deductions against Mortgagor.

7. Condemnation. If all or any part of the Premises are damaged, taken or acquired, either temporarily or permanently, in any condemnation proceeding, or by exercise of the right of eminent domain, the amount of any award or other payment for such taking or damages made in consideration thereof, to the extent of the full amount of the remaining unpaid Indebtedness, is hereby assigned to Mortgagee, who is empowered to collect and receive the same and to give proper receipts therefor in the name of Mortgagor and the same shall be paid forthwith to Mortgagee. Such award or monies shall be applied on account of the Indebtedness, irrespective of whether such Indebtedness is then due and payable and, at any time from and after the taking Mortgagee may declare the whole of the balance of the Indebtedness to be due and payable. Notwithstanding the provisions of this paragraph to the contrary, if any condemnation or taking of less than the entire Premises occurs and provided that no Event of Default and no event or circumstance which with the passage of time, the giving of notice or both would constitute an Event of Default then exists, and if such partial condemnation, in the reasonable discretion of Mortgagee, has no material adverse effect on the operation or value of the Premises, then the award or payment for such taking or consideration

for damages resulting therefrom may be collected and received by Mortgagor, and Mortgagee hereby agrees that in such event it shall not declare the Indebtedness to be due and payable, if it is not otherwise then due and payable.

8. Intentionally omitted.

9. Intentionally omitted.

10. **Effect of Extensions of Time and Other Changes.** If the payment of the Indebtedness or any part thereof is extended or varied, if any part of any security for the payment of the Indebtedness is released, if the rate of interest charged under the Note is changed or if the time for payment thereof is extended or varied, all persons now or at any time hereafter liable therefor, or interested in the Premises or having an interest in Mortgagor, shall be held to assent to such extension, variation, release or change and their liability and the lien and all of the provisions hereof shall continue in full force, any right of recourse against all such persons being expressly reserved by Mortgagee, notwithstanding such extension, variation, release or change.

11. **Effect of Changes in Laws Regarding Taxation.** If any law is enacted after the date hereof requiring (a) the deduction of any lien on the Premises from the value thereof for the purpose of taxation or (b) the imposition upon Mortgagee of the payment of the whole or any part of the Taxes, charges or liens herein required to be paid by Mortgagor, or (c) a change in the method of taxation of mortgages or debts secured by mortgages or Mortgagee's interest in the Premises, or the manner of collection of taxes, so as to affect this Mortgage or the Indebtedness or the holders thereof, then Mortgagor, upon demand by Mortgagee, shall pay such Taxes or charges, or reimburse Mortgagee therefor; provided, however, that Mortgagor shall not be deemed to be required to pay any income or franchise taxes of Mortgagee. Notwithstanding the foregoing, if in the opinion of counsel for Mortgagee it is or may be unlawful to require Mortgagor to make such payment or the making of such payment might result in the imposition of interest beyond the maximum amount permitted by law, then Mortgagee may declare all of the Indebtedness to be immediately due and payable.

12. **Mortgagee's Performance of Defaulted Acts and Expenses Incurred by Mortgagee.** If an Event of Default has occurred, Mortgagee may, but need not, make any payment or perform any act herein required of Mortgagor in any form and manner deemed expedient by Mortgagee, and may, but need not, make full or partial payments of principal or interest on prior encumbrances, if any, and purchase, discharge, compromise or settle any tax lien or other prior lien or title or claim thereof, or redeem from any tax sale or forfeiture affecting the Premises or consent to any tax or assessment or cure any default of Mortgagor in any lease of the Premises. All monies paid for any of the purposes herein authorized and all expenses paid or incurred in connection therewith, including reasonable attorneys' fees, and any other monies advanced by Mortgagee in regard to any tax referred to in Paragraph 8 above or to protect the Premises or the lien hereof, shall be so much additional Indebtedness, and shall become immediately due and payable by Mortgagor to Mortgagee, upon demand, and with interest thereon accruing from the date of such demand until paid at the Default Rate (as defined in the Note) then in effect. In addition to the foregoing, any costs, expenses and fees, including reasonable attorneys' fees, incurred by Mortgagee in connection with (a) sustaining the lien of this Mortgage or its priority, (b) protecting or enforcing any of Mortgagee's rights hereunder, (c) recovering any Indebtedness, (d) any litigation or proceedings affecting the Note, this Mortgage, any of the other Loan Documents or the Premises, including without limitation, bankruptcy and probate proceedings, or (e) preparing for the commencement, defense or participation in any threatened litigation or proceedings affecting the Note, this Mortgage, any of the other Loan Documents or the Premises, shall be so much additional Indebtedness, and shall become immediately due and payable by Mortgagor to Mortgagee, upon demand, and with interest thereon accruing from the date of such demand

until paid at the Default Rate. The interest accruing under this Paragraph 12 shall be immediately due and payable by Mortgagor to Mortgagee, and shall be additional Indebtedness evidenced by the Note and secured by this Mortgage. Mortgagee's failure to act shall never be considered as a waiver of any right accruing to Mortgagee on account of any Event of Default. Should any amount paid out or advanced by Mortgagee hereunder, or pursuant to any agreement executed by Mortgagor in connection with the Loan, be used directly or indirectly to pay off, discharge or satisfy, in whole or in part, any lien or encumbrance upon the Premises or any part thereof, then Mortgagee shall be subrogated to any and all rights, equal or superior titles, liens and equities, owned or claimed by any owner or holder of said outstanding liens, charges and indebtedness, regardless of whether said liens, charges and indebtedness are acquired by assignment or have been released of record by the holder thereof upon payment.

13. Security Agreement. Mortgagor and Mortgagee agree that this Mortgage shall constitute a Security Agreement within the meaning of the Code with respect to (a) all sums at any time on deposit for the benefit of Mortgagor or held by Mortgagee (whether deposited by or on behalf of Mortgagor or anyone else) pursuant to any of the provisions of this Mortgage or the other Loan Documents, and (b) with respect to any personal property included in the granting clauses of this Mortgage, which personal property may not be deemed to be affixed to the Premises or may not constitute a "fixture" (within the meaning of Section 9.1-102(41) of the Code) (which property is hereinafter referred to as "Personal Property"), and all replacements of, substitutions for, additions to, and the proceeds thereof, and the "supporting obligations" (as defined in the Code) (all of said Personal Property and the replacements, substitutions and additions thereto and the proceeds thereof being sometimes hereinafter collectively referred to as "Collateral"), and that a security interest in and to the Collateral is hereby granted to Mortgagee, and the Collateral and all of Mortgagor's right, title and interest therein are hereby assigned to Mortgagee, all to secure payment of the Indebtedness. All of the provisions contained in this Mortgage pertain and apply to the Collateral as fully and to the same extent as to any other property comprising the Premises; and the following provisions of this Paragraph shall not limit the applicability of any other provision of this Mortgage but shall be in addition thereto:

a. Mortgagor (being the Debtor as that term is used in the Code) is and will be the true and lawful owner of the Collateral and has rights in and the power to transfer the Collateral, subject to no liens, charges or encumbrances other than the lien hereof, other liens and encumbrances benefiting Mortgagee and no other party, and liens and encumbrances, if any, expressly permitted by the other Loan Documents.

b. The Collateral is to be used by Mortgagor solely for municipal purposes.

c. The Collateral will be kept at the Real Estate and, except for Obsolete Collateral (as hereinafter defined), will not be removed therefrom without the consent of Mortgagee (being the Secured Party as that term is used in the Code). The Collateral may be affixed to the Real Estate but will not be affixed to any other real estate.

d. The only persons having any interest in the Premises are Mortgagor, Mortgagee and holders of interests, if any, expressly permitted hereby.

e. No Financing Statement (other than Financing Statements showing Mortgagee as the sole secured party, or with respect to liens or encumbrances, if any, expressly permitted hereby) covering any of the Collateral or any proceeds thereof is on file in any public office except pursuant hereto; and Mortgagor, at its own cost and expense, upon demand, will furnish to Mortgagee such further information and will execute and deliver to Mortgagee such financing statements and other documents in form satisfactory to Mortgagee and will do all such acts as Mortgagee may request at any time or from time to time or as may be necessary or appropriate to establish and maintain a perfected security interest in the

Collateral as security for the Indebtedness, subject to no other liens or encumbrances, other than liens or encumbrances benefiting Mortgagee and no other party and liens and encumbrances (if any) expressly permitted hereby; and Mortgagor will pay the cost of filing or recording such financing statements or other documents, and this instrument, in all public offices wherever filing or recording is deemed by Mortgagee to be desirable. Mortgagor hereby irrevocably authorizes Mortgagee at any time, and from time to time, to file in any jurisdiction any initial financing statements and amendments thereto that (i) indicate the Collateral as all assets of Mortgagor (or words of similar effect), regardless of whether any particular asset comprised in the Collateral falls within the scope of Article 9.1 of the Uniform Commercial Code of the jurisdiction wherein such financing statement or amendment is filed, or as being of an equal or lesser scope or within greater detail, and (ii) contain any other information required by Article 9.1 of the Uniform Commercial Code of the jurisdiction wherein such financing statement or amendment is filed regarding the sufficiency or filing office acceptance of any financing statement or amendment, including whether Mortgagor is an organization, the type of organization and any organization identification number issued to Mortgagor, and in the case of a financing statement filed as a fixture filing or indicating Collateral as as-extracted collateral or timber to be cut, a sufficient description of real property to which the Collateral relates. Mortgagor agrees to furnish any such information to Mortgagee promptly upon request. Mortgagor further ratifies and affirms its authorization for any financing statements and/or amendments thereto, executed and filed by Mortgagee in any jurisdiction prior to the date of this Mortgage.

f. Upon an Event of Default hereunder, Mortgagee shall have the remedies of a secured party under the Code, including, without limitation, the right to take immediate and exclusive possession of the Collateral, or any part thereof, and for that purpose, so far as Mortgagor can give authority therefor, with or without judicial process, may enter (if this can be done without breach of the peace) upon any place which the Collateral or any part thereof may be situated and remove the same therefrom (provided that if the Collateral is affixed to real estate, such removal shall be subject to the conditions stated in the Code); and Mortgagee shall be entitled to hold, maintain, preserve and prepare the Collateral for sale, until disposed of, or may propose to retain the Collateral subject to Mortgagor's right of redemption in satisfaction of Mortgagor's obligations, as provided in the Code. Mortgagee may render the Collateral unusable without removal and may dispose of the Collateral on the Premises. Mortgagee may require Mortgagor to assemble the Collateral and make it available to Mortgagee for its possession at a place to be designated by Mortgagee which is reasonably convenient to both parties. Mortgagee will give Mortgagor at least ten (10) days' notice of the time and place of any public sale of the Collateral or of the time after which any private sale or any other intended disposition thereof is made. The requirements of reasonable notice shall be met if such notice is mailed, by certified United States mail or equivalent, postage prepaid, to the address of Mortgagor hereinafter set forth at least ten (10) days before the time of the sale or disposition. Mortgagee may buy at any public sale. Mortgagee may buy at private sale if the Collateral is of a type customarily sold in a recognized market or is of a type which is the subject of widely distributed standard price quotations. Any such sale may be held in conjunction with any foreclosure sale of the Premises. If Mortgagee so elects, the Premises and the Collateral may be sold as one lot. The net proceeds realized upon any such disposition, after deduction for the expenses of retaking, holding, preparing for sale, selling and the reasonable attorneys' fees and legal expenses incurred by Mortgagee, shall be applied against the Indebtedness in such order or manner as Mortgagee shall select. Mortgagee will account to Mortgagor for any surplus realized on such disposition.

g. The terms and provisions contained in this Paragraph 13, unless the context otherwise requires, shall have the meanings and be construed as provided in the Code.

h. This Mortgage is intended to be a financing statement within the purview of Section 9.1-502(b) of the Code with respect to the Collateral and the goods described herein, which goods are or may become fixtures relating to the Premises. The addresses of Mortgagor (Debtor) and Mortgagee (Secured

Party) are hereinbelow set forth. This Mortgage is to be filed for recording with the Office of the Recorder of the county or counties where the Premises are located.

i. To the extent permitted by applicable law, the security interest created hereby is specifically intended to cover all Leases between Mortgagor or its agents as lessor, and various tenants named therein, as lessee, including all extended terms and all extensions and renewals of the terms thereof, as well as any amendments to or replacement of said Leases, together with all of the right, title and interest of Mortgagor, as lessor thereunder.

j. Mortgagor represents and warrants that:

i. Mortgagor is the record owner of the Premises;

ii. Mortgagor's exact legal name is as set forth in the first paragraph of this Mortgage.

k. Mortgagor agrees that:

i. Where Collateral is in possession of a third party, Mortgagor will join with Mortgagee in notifying the third party of Mortgagee's interest and obtaining an acknowledgment from the third party that it is holding the Collateral for the benefit of Mortgagee;

ii. Mortgagor will cooperate with Mortgagee in obtaining control with respect to Collateral consisting of: deposit accounts, investment property, letter of credit rights and electronic chattel paper; and

iii. Until the Indebtedness is paid in full, Mortgagor will not change the state where it is located or change its company name without giving Mortgagee at least 30 days' prior written notice in each instance.

14. Restrictions on Transfer.

Mortgagor, without the prior written consent of Mortgagee, shall not effect, suffer or permit any transfer or conveyance of the Premises ("Prohibited Transfer").

15. Intentionally omitted.

16. Events of Default; Acceleration. Each of the following shall constitute an "Event of Default" for purposes of this Mortgage:

a. Mortgagor fails to pay (i) any installment of principal or interest payable pursuant to the Note on the date when due, or (ii) any other amount payable to Lender under the Note, this Mortgage or any of the other Loan Documents within five (5) days after the date when any such payment is due in accordance with the terms hereof or thereof;

b. Mortgagor fails to perform or cause to be performed any other obligation or observe any other condition, covenant, term, agreement or provision required to be performed or observed by Mortgagor under the Note, this Mortgage or any of the other Loan Documents; provided, however, that if such failure by its nature can be cured, then so long as the continued operation and safety of the Premises, and the priority, validity and enforceability of the liens created by the Mortgage or any of the other Loan Documents and the value of the Premises are not impaired, threatened or jeopardized, then Mortgagor shall have a period ("Cure Period") of thirty (30) days after Mortgagor obtains actual knowledge of such failure or

receives written notice of such failure to cure the same and an Event of Default shall not be deemed to exist during the Cure Period, provided further that if Mortgagor commences to cure such failure during the Cure Period and is diligently and in good faith attempting to effect such cure, the Cure Period shall be extended for thirty (30) additional days, but in no event shall the Cure Period be longer than sixty (60) days in the aggregate;

- c. the occurrence of a Prohibited Transfer; or
- d. the occurrence of an "Event of Default" under the Note, the Loan Agreement or any of the other Loan Documents; or
- e. the occurrence of any default or event of default, after the expiration of any applicable periods of notice or cure, under any document or agreement evidencing or securing any other obligation or indebtedness of Mortgagor to Mortgagee.

If an Event of Default occurs, Mortgagee may, at its option, declare the whole of the Indebtedness to be immediately due and payable without further notice to Mortgagor, with interest thereon accruing from the date of such Event of Default until paid at the Default Rate.

17. Foreclosure; Expense of Litigation.

a. When all or any part of the Indebtedness shall become due, whether by acceleration or otherwise, Mortgagee shall have the right to foreclose the lien hereof for such Indebtedness or part thereof and/or exercise any right, power or remedy provided in this Mortgage or any of the other Loan Documents in accordance with all Indiana foreclosure laws (as may be amended from time to time, the "Act"). In the event of a foreclosure sale, Mortgagee is hereby authorized, without the consent of Mortgagor, to assign any and all insurance policies to the purchaser at such sale or to take such other steps as Mortgagee may deem advisable to cause the interest of such purchaser to be protected by any of such insurance policies.

b. In any suit to foreclose the lien hereof, there shall be allowed and included as additional indebtedness in the decree for sale all expenditures and expenses which may be paid or incurred by or on behalf of Mortgagee for reasonable attorneys' fees, appraisers' fees, outlays for documentary and expert evidence, stenographers' charges, publication costs, and costs (which may be estimated as to items to be expended after entry of the decree) of procuring all such abstracts of title, title searches and examinations, title insurance policies, and similar data and assurances with respect to the title as Mortgagee may deem reasonably necessary either to prosecute such suit or to evidence to bidders at any sale which may be had pursuant to such decree the true condition of the title to or the value of the Premises. All expenditures and expenses of the nature mentioned in this paragraph and such other expenses and fees as may be incurred in the enforcement of Mortgagor's obligations hereunder, the protection of said Premises and the maintenance of the lien of this Mortgage, including the reasonable fees of any attorney employed by Mortgagee in any litigation or proceeding affecting this Mortgage, the Note, or the Premises, including probate and bankruptcy proceedings, or in preparations for the commencement or defense of any proceeding or threatened suit or proceeding shall be immediately due and payable by Mortgagor, with interest thereon until paid at the Default Rate and shall be secured by this Mortgage.

18. Application of Proceeds of Foreclosure Sale. The proceeds of any foreclosure sale of the Premises shall be distributed and applied in accordance with the Act and, unless otherwise specified therein, in such order as Mortgagee may determine in its sole and absolute discretion.

19. Appointment of Receiver. Upon or at any time after the filing of a complaint to foreclose this Mortgage, the court in which such complaint is filed shall, upon petition by Mortgagee, appoint a receiver for the Premises in accordance with the Act. Such appointment may be made either before or after sale, without notice, without regard to the solvency or insolvency of Mortgagor at the time of application for such receiver and without regard to the value of the Premises or whether the same shall be then occupied as a homestead or not and Mortgagee hereunder or any other holder of the Note may be appointed as such receiver. Such receiver shall have power to collect the rents, issues and profits of the Premises (i) during the pendency of such foreclosure suit, (ii) in case of a sale and a deficiency, during the full statutory period of redemption, whether there be redemption or not, and (iii) during any further times when Mortgagor, but for the intervention of such receiver, would be entitled to collect such rents, issues and profits. Such receiver also shall have all other powers and rights that may be necessary or are usual in such cases for the protection, possession, control, management and operation of the Premises during said period, including, to the extent permitted by law, the right to lease all or any portion of the Premises for a term that extends beyond the time of such receiver's possession without obtaining prior court approval of such lease. The court from time to time may authorize the application of the net income received by the receiver in payment of (a) the Indebtedness, or by any decree foreclosing this Mortgage, or any tax, special assessment or other lien which may be or become superior to the lien hereof or of such decree, provided such application is made prior to foreclosure sale, and (b) any deficiency upon a sale and deficiency.

20. Mortgagee's Right of Possession in Case of Default. At any time after an Event of Default has occurred, Mortgagor shall, upon demand of Mortgagee, surrender to Mortgagee possession of the Premises. Mortgagee, in its discretion, may, with process of law, enter upon and take and maintain possession of all or any part of the Premises, together with all documents, books, records, papers and accounts relating thereto, and may exclude Mortgagor and its employees, agents or servants therefrom, and Mortgagee may then hold, operate, manage and control the Premises, either personally or by its agents. Mortgagee shall have full power to use such measures, legal or equitable, as in its discretion may be deemed proper or necessary to enforce the payment or security of the avails, rents, issues, and profits of the Premises, including actions for the recovery of rent, actions in forcible detainer and actions in distress for rent. Without limiting the generality of the foregoing, Mortgagee shall have full power to:

a. cancel or terminate any lease, sublease or purchase agreement for any cause or on any ground which would entitle Mortgagor to cancel the same;

b. elect to disaffirm any lease, sublease or purchase agreement which is then subordinate to the lien hereof;

c. extend or modify any then existing leases and to enter into new leases, which extensions, modifications and leases may provide for terms to expire, or for options to lessees to extend or renew terms to expire, beyond the Maturity Date and beyond the date of the issuance of a deed or deeds to a purchaser or purchasers at a foreclosure sale, it being understood and agreed that any such leases, and the options or other such provisions to be contained therein, shall be binding upon Mortgagor and all persons whose interests in the Premises are subject to the lien hereof and upon the purchaser or purchasers at any foreclosure sale, notwithstanding any redemption from sale, discharge of the Indebtedness, satisfaction of any foreclosure judgment, or issuance of any certificate of sale or deed to any purchaser;

d. make any repairs, renewals, replacements, alterations, additions, betterments and improvements to the Premises as Mortgagee deems are necessary;

e. insure and reinsure the Premises and all risks incidental to Mortgagee's possession, operation and management thereof; and

f. receive all of such avails, rents, issues and profits.

21. Application of Income Received by Mortgagee. Mortgagee, in the exercise of the rights and powers hereinabove conferred upon it, shall have full power to use and apply the avails, rents, issues and profits of the Premises to the payment of or on account of the following, in such order as Mortgagee may determine:

a. to the payment of the operating expenses of the Premises, including cost of management and leasing thereof (which shall include compensation to Mortgagee and its agent or agents, if management be delegated to an agent or agents, and shall also include lease commissions and other compensation and expenses of seeking and procuring tenants and entering into leases), established claims for damages, if any, and premiums on insurance hereinabove authorized;

b. to the payment of taxes and special assessments now due or which may hereafter become due on the Premises; and

c. to the payment of any Indebtedness, including any deficiency which may result from any foreclosure sale.

22. Rights Cumulative. Each right, power and remedy herein conferred upon Mortgagee is cumulative and in addition to every other right, power or remedy, express or implied, given now or hereafter existing under any of the Loan Documents or at law or in equity, and each and every right, power and remedy herein set forth or otherwise so existing may be exercised from time to time as often and in such order as may be deemed expedient by Mortgagee, and the exercise or the beginning of the exercise of one right, power or remedy shall not be a waiver of the right to exercise at the same time or thereafter any other right, power or remedy, and no delay or omission of Mortgagee in the exercise of any right, power or remedy accruing hereunder or arising otherwise shall impair any such right, power or remedy, or be construed to be a waiver of any Event of Default or acquiescence therein.

23. Mortgagee's Right of Inspection. Mortgagee and its representatives shall have the right to inspect the Premises and the books and records with respect thereto at all reasonable times upon not less than twenty four (24) hours prior notice to Mortgagor, and access thereto, subject to the rights of tenants in possession, shall be permitted for that purpose.

24. Release Upon Payment and Discharge of Mortgagor's Obligations. Mortgagee shall release this Mortgage and the lien hereof by proper instrument upon payment and discharge of all Indebtedness, including payment of all reasonable expenses incurred by Mortgagee in connection with the execution of such release.

25. Notices. Any notices, communications and waivers under this Mortgage shall be in writing and shall be (i) delivered in person, (ii) mailed, postage prepaid, either by registered or certified mail, return receipt requested, or (iii) by overnight express carrier, addressed in each case as follows:

To Mortgagee:

Avon MAP, LLC  
1345C Brookville Way  
Indianapolis, Indiana 46239  
Attn: Marc Freije

To Mortgagor:

Town of Avon, Indiana  
6570 E. US Highway 36  
Avon, Indiana Town Manager  
Attn: Town Manager

or to any other address as to any of the parties hereto, as such party shall designate in a written notice to the other party hereto. All notices sent pursuant to the terms of this Paragraph shall be deemed received (i) if personally delivered, then on the date of delivery, (ii) if sent by overnight, express carrier, then on the next federal banking day immediately following the day sent, or (iii) if sent by registered or certified mail, then on the earlier of the third federal banking day following the day sent or when actually received.

26. Waiver of Rights. Mortgagor hereby covenants and agrees that it will not at any time insist upon or plead, or in any manner claim or take any advantage of, any stay, exemption or extension law or any so called "Moratorium Law" now or at any time hereafter in force providing for the valuation or appraisal of the Premises, or any part thereof, prior to any sale or sales thereof to be made pursuant to any provisions herein contained, or to decree, judgment or order of any court of competent jurisdiction; or, after such sale or sales, claim or exercise any rights under any statute now or hereafter in force to redeem the property so sold, or any part thereof, or relating to the marshalling thereof, upon foreclosure sale or other enforcement hereof; and without limiting the foregoing:

a. Mortgagor hereby expressly waives any and all rights of reinstatement and redemption, if any, under any order or decree of foreclosure of this Mortgage, on its own behalf and on behalf of each and every person, it being the intent hereof that any and all such rights of reinstatement and redemption of Mortgagor and of all other persons are and shall be deemed to be hereby waived to the full extent permitted by the provisions of applicable law or replacement statutes;

b. Mortgagor will not invoke or utilize any such law or laws or otherwise hinder, delay or impede the execution of any right, power remedy herein or otherwise granted or delegated to Mortgagee but will suffer and permit the execution of every such right, power and remedy as though no such law or laws had been made or enacted; and

c. If Mortgagor is a trustee, Mortgagor represents that the provisions of this paragraph (including the waiver of reinstatement and redemption rights) were made at the express direction of Mortgagor's beneficiaries and the persons having the power of direction over Mortgagor, and are made on behalf of the trust estate of Mortgagor and all beneficiaries of Mortgagor, as well as all other persons mentioned above.

27. Contests. Notwithstanding anything to the contrary herein contained, Mortgagor shall have the right to contest by appropriate legal proceedings diligently prosecuted any Taxes imposed or assessed upon the Premises or which may be or become a lien thereon and any mechanics', materialmen's or other liens or claims for lien upon the Premises (all herein called "Contested Liens"), and no Contested Liens shall constitute an Event of Default hereunder, if, but only if:

a. Mortgagor shall forthwith give notice of any Contested Lien to Mortgagee at the time the same shall be asserted;

b. Mortgagor shall either pay under protest or deposit with Mortgagee the full amount (herein called "Lien Amount") of such Contested Lien, together with such amount as Mortgagee may reasonably estimate as interest or penalties which might arise during the period of contest; provided that in lieu of such payment Mortgagor may furnish to Mortgagee a bond or title indemnity in such amount and form, and issued by a bond or title insuring company, as may be satisfactory to Mortgagee;

c. Mortgagor shall diligently prosecute the contest of any Contested Lien by appropriate legal proceedings having the effect of staying the foreclosure or forfeiture of the Premises, and shall permit Mortgagee to be represented in any such contest and shall pay all expenses incurred, in so doing, including fees and expenses of Mortgagee's counsel (all of which shall constitute so much additional Indebtedness bearing interest at the Default Rate until paid, and payable upon demand);

d. Mortgagor shall pay such Contested Lien and all Lien Amounts together with interest and penalties thereon (i) if and to the extent that any such Contested Lien shall be determined adverse to Mortgagor, or (ii) forthwith upon demand by Mortgagee if, in the opinion of Mortgagee, and notwithstanding any such contest, the Premises shall be in jeopardy or in danger of being forfeited or foreclosed; provided that if Mortgagor shall fail so to do, Mortgagee may, but shall not be required to, pay all such Contested Liens and Lien Amounts and interest and penalties thereon and such other sums as may be necessary in the judgment of Mortgagee to obtain the release and discharge of such liens; and any amount expended by Mortgagee in so doing shall be so much additional Indebtedness bearing interest at the Default Rate until paid, and payable upon demand; and provided further that Mortgagee may in such case use and apply monies deposited as provided in subsection (b) above and may demand payment upon any bond or title indemnity furnished as aforesaid.

28. Expenses Relating to Note and Mortgage.

a. Mortgagor will pay all expenses, charges, costs and fees relating to the Loan or necessitated by the terms of the Note, this Mortgage or any of the other Loan Documents, including without limitation, Mortgagee's reasonable attorneys' fees in connection with the negotiation, documentation, administration, servicing and enforcement of the Note, this Mortgage and the other Loan Documents, all filing, registration and recording fees, all other expenses incident to the execution and acknowledgment of this Mortgage and all federal, state, county and municipal taxes, and other taxes (provided Mortgagor shall not be required to pay any income or franchise taxes of Mortgagee), duties, imposts, assessments and charges arising out of or in connection with the execution and delivery of the Note and this Mortgage. Mortgagor recognizes that, during the term of this Mortgage, Mortgagee:

i. Shall not be involved in court or administrative proceedings, including, without restricting the foregoing, foreclosure, probate, bankruptcy, creditors' arrangements, insolvency, housing authority and pollution control proceedings of any kind, to which Mortgagee shall be a party by reason of the Loan Documents or in which the Loan Documents or the Premises are involved directly or indirectly;

ii. Shall not make preparations following the occurrence of an Event of Default hereunder for the commencement of any suit for the foreclosure hereof, which may or may not be actually commenced;

iii. Shall not make preparations following the occurrence of an Event of Default hereunder for, and do work in connection with, Mortgagee's taking possession of and managing the Premises, which event may or may not actually occur;

iv. Shall not make preparations for and commence other private or public actions to remedy an Event of Default hereunder, which other actions may or may not be actually commenced;

v. Shall not enter into negotiations with Mortgagor or any of its agents, employees or attorneys in connection with the existence or curing of any Event of Default hereunder, the sale of the Premises, the assumption of liability for any of the Indebtedness or the transfer of the Premises in lieu of foreclosure; or

vi. Shall not enter into negotiations with Mortgagor or any of its agents, employees or attorneys pertaining to Mortgagee's approval of actions taken or proposed to be taken by Mortgagor which approval is required by the terms of this Mortgage.

b. All expenses, charges, costs and fees described in this Paragraph 28 shall be so much additional Indebtedness, shall bear interest from the date so incurred until paid at the Default Rate and shall be paid, together with said interest, by Mortgagor forthwith upon demand.

29. Intentionally omitted.

30. Intentionally omitted.

31. Further Instruments. Upon request of Mortgagee, Mortgagor shall execute, acknowledge and deliver all such additional instruments and further assurances of title and shall do or cause to be done all such further acts and things as may reasonably be necessary fully to effectuate the intent of this Mortgage and of the other Loan Documents.

32. Additional Indebtedness Secured. All persons and entities with any interest in the Premises or about to acquire any such interest should be aware that this Mortgage secures more than the stated principal amount of the Note and interest thereon; this Mortgage secures any and all other amounts which may become due under the Note or any other document or instrument evidencing, securing or otherwise affecting the Indebtedness, including, without limitation, any and all amounts expended by Mortgagee to operate, manage or maintain the Premises or to otherwise protect the Premises or the lien of this Mortgage.

33. Indemnity. Mortgagor hereby covenants and agrees that no liability shall be asserted or enforced against Mortgagee in the exercise of the rights and powers granted to Mortgagee in this Mortgage, and Mortgagor hereby expressly waives and releases any such liability. Mortgagor shall indemnify and save Mortgagee harmless from and against any and all liabilities, obligations, losses, damages, claims, costs and expenses (including reasonable attorneys' fees and court costs) (collectively, "Claims") of whatever kind or nature which may be imposed on, incurred by or asserted against Mortgagee at any time by any third party which relate to or arise from: (a) any suit or proceeding (including probate and bankruptcy proceedings), or the threat thereof, in or to which Mortgagee may or does become a party, either as plaintiff or as a defendant, by reason of this Mortgage or for the purpose of protecting the lien of this Mortgage; (b) the offer for sale or sale of all or any portion of the Premises; and (c) the ownership, leasing, use, operation or maintenance of the Premises, if such Claims relate to or arise from actions taken prior to the surrender of possession of the Premises to Mortgagee in accordance with the terms of this Mortgage; provided, however, that Mortgagor shall not be obligated to indemnify or hold Mortgagee harmless from and against any Claims directly arising from the gross negligence or willful misconduct of Mortgagee. All costs provided for herein and paid for by Mortgagee shall be so much additional Indebtedness and shall become immediately due and payable upon demand by Mortgagee and with interest thereon from the date incurred by Mortgagee until paid at the Default Rate.

34. Compliance with Environmental Laws. Mortgagor acknowledges that concurrently herewith Mortgagor has executed and delivered to Mortgagee an Environmental Indemnity Agreement ("Indemnity") pursuant to which Mortgagor has fully indemnified Mortgagee for certain environmental

matters concerning the Premises, as more particularly described therein. The provisions of the Indemnity are hereby incorporated herein and this Mortgage shall secure the obligations of Mortgagor thereunder. Mortgagor agrees to abide by all of the provisions of the Indemnity.

35. Miscellaneous.

a. Successors and Assigns. This Mortgage and all provisions hereof shall be binding upon and enforceable against Mortgagor and its assigns and other successors. This Mortgage and all provisions hereof shall inure to the benefit of Mortgagee, its successors and assigns and any holder or holders, from time to time, of the Note.

b. Invalidity of Provisions; Governing Law. In the event that any provision of this Mortgage is deemed to be invalid by reason of the operation of law, or by reason of the interpretation placed thereon by any administrative agency or any court, Mortgagor and Mortgagee shall negotiate an equitable adjustment in the provisions of the same in order to effect, to the maximum extent permitted by law, the purpose of this Mortgage and the validity and enforceability of the remaining provisions, or portions or applications thereof, shall not be affected thereby and shall remain in full force and effect. This Mortgage is to be construed in accordance with and governed by the laws of the State of Indiana.

c. Municipal Requirements. Mortgagor shall not by act or omission permit any building or other improvement on premises not subject to the lien of this Mortgage to rely on the Premises or any part thereof or any interest therein to fulfill any municipal or governmental requirement, and Mortgagor hereby assigns to Mortgagee any and all rights to give consent for all or any portion of the Premises or any interest therein to be so used. Similarly, no building or other improvement on the Premises shall rely on any premises not subject to the lien of this Mortgage or any interest therein to fulfill any governmental or municipal requirement. Any act or omission by Mortgagor which would result in a violation of any of the provisions of this subparagraph shall be void.

d. Rights of Tenants. Mortgagee shall have the right and option to commence a civil action to foreclose this Mortgage and to obtain a decree of foreclosure and sale subject to the rights of any tenant or tenants of the Premises having an interest in the Premises prior to that of Mortgagee. The failure to join any such tenant or tenants of the Premises as party defendant or defendants in any such civil action or the failure of any decree of foreclosure and sale to foreclose their rights shall not be asserted by Mortgagor as a defense in any civil action instituted to collect the Indebtedness, or any part thereof or any deficiency remaining unpaid after foreclosure and sale of the Premises, any statute or rule of law at any time existing to the contrary notwithstanding.

e. Option of Mortgagee to Subordinate. At the option of Mortgagee, this Mortgage shall become subject and subordinate, in whole or in part (but not with respect to priority of entitlement to insurance proceeds or any condemnation or eminent domain award) to any and all leases of all or any part of the Premises upon the execution by Mortgagee of a unilateral declaration to that effect and the recording thereof in the Office of the Recorder of Deeds in and for the county wherein the Premises are situated.

f. Mortgagee in Possession. Nothing herein contained shall be construed as constituting Mortgagee a mortgagee in possession in the absence of the actual taking of possession of the Premises by Mortgagee pursuant to this Mortgage.

g. Relationship of Mortgagee and Mortgagor. Mortgagee shall in no event be construed for any purpose to be a partner, joint venturer, agent or associate of Mortgagor or of any lessee, operator, concessionaire or licensee of Mortgagor in the conduct of their respective businesses, and, without limiting

the foregoing, Mortgagee shall not be deemed to be such partner, joint venturer, agent or associate on account of Mortgagee becoming a mortgagee in possession or exercising any rights pursuant to this Mortgage, any of the other Loan Documents, or otherwise. The relationship of Mortgagor and Mortgagee hereunder is solely that of debtor/creditor.

h. Time of the Essence. Time is of the essence of the payment by Mortgagor of all amounts due and owing to Mortgagee under the Note and the other Loan Documents and the performance and observance by Mortgagor of all terms, conditions, obligations and agreements contained in this Mortgage and the other Loan Documents.

i. No Merger. The parties hereto intend that the Mortgage and the lien hereof shall not merge in fee simple title to the Premises, and if Mortgagee acquires any additional or other interest in or to the Premises or the ownership thereof, then, unless a contrary intent is manifested by Mortgagee as evidenced by an express statement to that effect in an appropriate document duly recorded, this Mortgage and the lien hereof shall not merge in the fee simple title and this Mortgage may be foreclosed as if owned by a stranger to the fee simple title.

j. Maximum Indebtedness. Notwithstanding anything contained herein to the contrary, in no event shall the Indebtedness exceed an amount equal to Two Million One Hundred Four Thousand and 00/100 Dollars (\$2,104,000.00); provided, however, in no event shall Mortgagee be obligated to advance funds in excess of the face amount of the Note.

k. Complete Agreement. This Mortgage, the Note and the other Loan Documents constitute the complete agreement between the parties with respect to the subject matter hereof and the Loan Documents may not be modified, altered or amended except by an agreement in writing signed by both Mortgagor and Mortgagee.

*(signature page follows)*

**SIGNATURE PAGE TO MORTGAGE**

IN WITNESS WHEREOF, Mortgagor has executed and delivered this Mortgage the day and year first above written.

TOWN OF AVON, INDIANA

By: Exhibit Only; No Signature Required Until Closing

Printed: \_\_\_\_\_

Title: \_\_\_\_\_

STATE OF INDIANA )

) SS:

COUNTY OF \_\_\_\_\_)

Before me, a Notary Public in and for said County and State, personally appeared \_\_\_\_\_, the \_\_\_\_\_ of Town of Avon, Indiana, who, being duly sworn upon his/her oath, acknowledged his/her execution of the above and foregoing instrument for and on behalf of said town.

Dated this \_\_\_\_ day of \_\_\_\_\_, 2026.

\_\_\_\_\_

\_\_\_\_\_, Notary Public

County of Residence:

\_\_\_\_\_

My Commission Expires:

\_\_\_\_\_

Commission Number:

\_\_\_\_\_

This Instrument prepared by: Steven J. Glazier, Cohen Garelick & Glazier, 8888 Keystone Crossing Blvd., Suite 800, Indianapolis, IN 46240

I affirm, under penalties for perjury, that I have taken reasonable care to redact each Social Security Number in this document, unless required by law. Steven J. Glazier

**EXHIBIT A**

**LEGAL DESCRIPTION OF PREMISES**

**EXHIBIT B**

PERMITTED EXCEPTIONS

1. General real estate taxes for the year 2025, payable in 2026, and each year thereafter not yet due and payable.

2. Exception Nos. \_\_\_\_\_, inclusive, contained on Schedule B - Section 2 of \_\_\_\_\_ Title Insurance Company, File No. \_\_\_\_\_, dated \_\_\_\_\_

## Exhibit D

### Form of Environmental Indemnity Agreement

#### ENVIRONMENTAL INDEMNITY AGREEMENT

THIS ENVIRONMENTAL INDEMNITY AGREEMENT (the “Agreement”) is made effective as of \_\_\_\_\_, 2026 (the “Effective Date”), by TOWN OF AVON, INDIANA (the “Borrower”), in favor of AVON MAP, LLC, an Indiana limited liability company (“Lender”).

#### RECITALS

A. Borrower is the fee simple owner of the real estate located in Avon, Hendricks County, Indiana, more particularly described on Exhibit A attached hereto and made a part hereof (such real estate, together with all improvements now or hereafter located thereon, being referred to herein as the “Property”).

B. Lender is prepared to make to Borrower and Borrower is prepared to accept from Lender a term loan in the amount of \$1,052,500.00 (the “Loan”).

C. The Loan is evidenced by, among other documents, that certain (i) Promissory Note Secured by Mortgage dated of even date herewith executed by Borrower in favor of Lender in the original principal amount of \$1,052,000.00, as the same may be amended, restated or replaced from time to time (together, the “Note”).

D. The Loan is secured by, among other things, a certain Mortgage, Security Agreement, Assignment of Leases and Rents and Fixture Filing encumbering the Property (the “Mortgage”).

E. The Note, the Mortgage, this Agreement and any and all other documents and instruments evidencing, documenting and relating to the Loan are hereinafter collectively referred to as the “Loan Documents”.

F. As an inducement to Lender to make the Loan, Borrower has agreed to enter into this Agreement.

#### AGREEMENT

NOW, THEREFORE, in consideration of the premises and other good and valuable consideration, the receipt and sufficiency of which are hereby acknowledged, Borrower makes the following representations, warranties, covenants and agreements in favor of and for the benefit of Lender:

1. Definitions. The following terms shall have the following meanings for purposes of this Agreement:
  - (a) “Hazardous Constituent” shall have the meaning assigned thereto under 40 C.F.R. § 260.10.
  - (b) “Hazardous Materials” shall mean, collectively, Hazardous Substances, Hazardous Constituent and Solid Wastes.
  - (c) “Hazardous Materials Laws” shall mean all applicable laws, statutes, ordinances, rules,

regulations, permits, licenses, judgments, writs, injunctions, decrees, orders, determinations, directives, awards and standards promulgated by any governmental authority concerning Hazardous Materials or concerning the protection of, or regulation of the discharge of substances into, the environment or concerning the health or safety of persons with respect to environmental hazards, and includes, without limitation, the Comprehensive Environmental Response, Compensation and Liability Act of 1980, as amended by the Superfund Amendments and Reauthorization Act of 1986, 42 U.S.C. §§ 9601 et seq., Solid Waste Disposal Act, as amended by the Resource Conservation and Recovery Act of 1976 and Solid and Hazardous Waste Amendments of 1984, 42 U.S.C. §§ 6901 et seq., Federal Water Pollution Control Act, as amended by the Clean Water Act of 1977, 33 U.S.C. §§ 1251 et seq., Clean Air Act of 1966, as amended, 42 U.S.C. §§ 7401 et seq., Toxic Substances Control Act of 1976, 15 U.S.C. §§ 2601 et seq., Occupational Safety and Health Act of 1970, as amended, 29 U.S.C. §§ 651 et seq., Emergency Planning and Community Right-to-Know Act of 1986, 42 U.S.C. §§ 11001 et seq., National Environmental Policy of 1975, 42 U.S.C. §§ 4321 et seq., Safe Drinking Water Act of 1974, as amended, 42 U.S.C. § 300(f) et seq., the Hazardous Materials Transportation Act, 42, U.S.C. § 1801 et seq., the Federal Insecticide, Fungicide, and Rodenticide Act, U. S.C. § 7401 et seq., and any similar or implementing law of the State of Indiana, and all amendments, rules, and regulations promulgated thereunder or implementing the same.

(d) “Hazardous Substances” shall mean at any time any substance, waste, pollutant, contaminant or material, in solid, liquid or gaseous form, which: (i) is a substance regulated or defined or designated as hazardous, extremely or imminently hazardous, objectionable, dangerous, or toxic pursuant to any applicable law, by any local, state, territorial or federal governmental authority; (ii) is a substance with respect to which such a governmental authority otherwise requires environmental compliance, investigation, monitoring, reporting, or remediation; including but not limited to, (A) all substances, wastes, pollutants, contaminants and materials regulated, or defined or designated as hazardous, extremely or imminently hazardous, dangerous, objectionable or toxic, under any applicable Hazardous Materials Law; (B) petroleum and petroleum based products including crude oil, used oil and any fractions thereof; (C) natural gas, synthetic gas, and any mixtures thereof; (D) radon; (E) radioactive substances and materials; (F) asbestos; (G) urea formaldehyde; (H) polychlorinated biphenyls; (I) lead; (J) methane; (K) flammable substances and materials ; and (L) explosives.

(e) “Solid Wastes” shall have the meaning assigned thereto in 40 C.F.R. § 261.2.

(f) “Storage Containers” shall mean existing and future containers for Hazardous Materials and above ground and underground storage tank systems (including underground piping, conduits or sumps).

(g) “Wetlands Laws” means, without limitation, 33 C.F.R. § 328.3 and any comparable applicable state and local law, statute, ordinances, rule or regulation.

Terms that are capitalized in this Agreement but that are not otherwise defined in this Agreement, but defined in any other document or agreement executed in connection with the Loan shall have meaning ascribed to them in such other document or agreement.

## 2. **Representations and Indemnity.**

(a) Borrower represents that, to the best of its knowledge: (i) neither Borrower nor any previous owner, tenant, occupant or other user of the Property has used, generated, stored, treated, produced, handled or disposed of in, on, under, around or above the Property, any Hazardous Materials in violation of any Hazardous Materials Laws; (ii) the Property is not currently in violation of any Hazardous Materials Laws or Wetlands Laws; (iii) the Property does not now contain and has not in the past contained any Hazardous Materials in violation of any Hazardous Materials Laws; (iv) the Property does not now

contain and has not in the past contained any Storage Containers in violation of any Hazardous Materials Laws; (v) no event has occurred with respect to the Property which, with the passage of time or the giving of notice or both, would constitute a violation of any Hazardous Materials Laws or Wetlands Laws; (vi) there are no agreements, orders, determinations, permits or directives of or with any federal, state or local governmental agency or authority relating to the Property that require any work, repair, construction, containment, clean up, investigation, study, removal, mitigation or other environmental remedial action with respect to the Property; and (vii) there are no actions, suits, claims, proceedings or investigations, pending or threatened, arising out of or relating to the Property and any Hazardous Materials Laws or Wetlands Laws.

(b) Borrower covenants and agrees that: (i) Borrower shall, and Borrower shall cause all employees, agents, contractors and subcontractors of Borrower and all other persons who now or hereafter are present on or occupying the Property to keep and maintain the Property, including, without limitation, the soil and ground water thereof, in compliance with, and not cause or knowingly permit the Property, including the soil and ground water thereof, to be in violation of, any applicable federal, state or local statutes, laws, ordinances, rules, guidelines, regulations, orders or directives relating to industrial hygiene or to the environmental condition thereof (including, but not limited to, any Hazardous Material Laws or Wetlands Laws); and (ii) neither Borrower nor any employees, agents, contractors or subcontractors of Borrower nor any other persons who now or hereafter occupy or are present on the Property shall (y) use, handle, generate, manufacture, store or dispose of, on, under, around or above the Property or transport to or from the Property Hazardous Materials, except as such may be required to be used, stored, handled or transported in connection with the permitted uses of the Property, and then only to the extent permitted by law and in strict compliance with all applicable statutes, laws, ordinances, rules, guidelines and regulations, including, but not limited to, Hazardous Materials Laws, and only after obtaining and keeping in force all necessary permits, approvals and licenses therefor; or (z) perform, cause to be performed or permit any fill activities or other acts that would in any way fill, destroy, eliminate, alter, obstruct, interfere with, or otherwise affect any "Wetlands" in violation of any Wetlands Laws.

(c) Borrower covenants and agrees to immediately notify Lender in writing of: (i) any notices (whether such notices are received from the Environmental Protection Agency, or any other federal, state or local governmental agency or regional office thereof) of an actual violation or potential violation by the Property that is received by Borrower of any Hazardous Materials Laws or of any Wetlands Laws; (ii) any enforcement, cleanup, removal or other governmental or regulatory demands made or actions threatened, instituted or completed with respect to the Property pursuant to any Hazardous Materials Laws or Wetlands Laws; (iii) any claims or demands made or threatened by any third party against Borrower with respect to the Property relating to actual or alleged damage, contribution obligations, cost recovery compensation, loss or injury resulting from any Hazardous Materials or Wetlands (the matters set forth in clauses (i), (ii) and (iii) above are hereinafter referred to as "Hazardous Materials or Wetlands Claims"); and (iv) Borrower's discovery of any occurrence or condition in, on, under, around or above the Property or any real property adjoining or in the vicinity of the Property that could cause the Property or any part thereof to be classified as "border zone property" under the provisions of any Hazardous Materials Laws, or to be otherwise subject to any restrictions on the ownership, occupancy, transferability or use of the Property under any Hazardous Materials Laws or Wetlands Laws.

(d) Lender shall have the right, but not the obligation, to join and participate in, as a party if Lender so elects, any legal proceedings or actions initiated in connection with any Hazardous Materials or Wetlands Claims and to have Lender's reasonable attorneys' and consultants' fees in connection therewith paid by Borrower upon demand.

(e) Except for any losses caused solely by the negligence or willful misconduct of Lender and

for matters caused and first occurring after Lender takes possession of the Property by foreclosure or deed-in-lieu of foreclosure, Borrower shall be solely responsible for, and Borrower agrees, at their sole cost and expense, to indemnify, protect and hold harmless Lender, its directors, officers, employees, agents, successors and assigns, ("Lender Indemnified Parties"), from and against, any claim, action, cause of action, loss, damage, cost (including, without limitation, reasonable attorneys' fees and consultants' fees), expense, liability, obligation, penalty, demand, suit, proceeding, or disbursement directly or indirectly, in whole or in part, arising out of or attributable to ("Claims"): (i) the breach, violation or threatened violation of any applicable environmental law, ordinance, regulation, rule, order, determination, directive or permit, including, but not limited to, Hazardous Materials Laws and Wetlands Laws, relating to Borrower and/or the Property; (ii) the existence of any Storage Container on or under the Property; and (iii) the use, handling, generation, storage, release, threatened release, discharge, disposal, or presence (whether prior to, during or after the term of the Loan) of Hazardous Materials or Wetlands in, on, under or about the Property (whether by Borrower or a predecessor in title or past, present or future tenant, occupant or other user or any employees, agents, contractor or subcontractors of Borrower or any predecessor in title or any third persons at any time occupying or present on the Property). For the purposes of this Agreement, Claims shall include, without limitation: (A) all consequential damages; (B) the cost of any required or necessary repair, response, cleanup, remediation or detoxification of the Property or any adjoining property, including the soil and ground water thereof, and the preparation and implementation of any closure, remedial or other required plans incurred by Lender; (C) damage to any Wetlands or natural resources; and (D) all costs and expenses incurred by Lender in connection with clauses (A), (B), and (C), including but not limited to reasonable attorneys' and consultants' fees; provided, however, that nothing contained in this paragraph shall be deemed to (i) create or give any rights to any person other than Lender Indemnified Parties it being intended that there shall be no third party beneficiary of such provisions, other than Lender Indemnified Parties, or (ii) preclude Borrower from seeking indemnification from, or otherwise proceeding against, any third party including, without limitation, any tenant or predecessor in title to the Property.

(f) Any costs or expenses incurred by Lender for which Borrower is responsible or for which Borrower has indemnified Lender shall be paid to Lender on demand, and failing prompt reimbursement, shall earn interest at the highest default rate of interest specified in the Note, as applicable, until paid in full.

(g) Borrower shall promptly notify Lender if Borrower or any third party takes any remedial action in response to the presence or potential presence of any Hazardous Materials or Wetlands in, on, under, around or above the Property or enters into any settlement agreement, consent decree, or other compromise in respect to any Hazardous Material or Wetlands Claims.

(h) If Lender reasonably determines after the date hereof that the environmental condition of the Property is materially and adversely different from, or has materially and adversely changed from, the environmental condition of the Property as of the date hereof, upon Lender's request, Borrower shall retain, at the sole cost and expense of Borrower, a licensed geologist, industrial hygienist or an environmental consultant (the "Consultant") acceptable to Lender, acting reasonably, to conduct a baseline investigation of the Property for the suspected presence of Hazardous Materials or Wetlands ("Environmental Study"). The Environmental Study shall be performed in a manner reasonably calculated to discover the presence of Hazardous Materials contamination or Wetlands and shall be conducted in accordance with the general standards of persons providing such services, taking into consideration the known current and past uses of the Property and property in the vicinity of the Property and any factors unique to the Property. The Consultant shall concurrently deliver the results, recommendations and conclusions of its investigation (the "Report") in writing directly to Borrower and Lender. Borrower shall cause the Consultant to permit Lender to rely on the results, recommendations and conclusions contained in the Report.

(i) If Borrower fails to pay for or obtain an Environmental Study as provided for herein, Lender may, but shall not be obligated to, obtain the Environmental Study at the cost and expense of Borrower and receive reimbursement from Borrower for any cost or expense of Lender incurred in so doing, in which case interest shall accrue on such sum at the highest default rate of interest specified in the Note.

(j) Borrower covenants to cooperate with the Consultant and to allow entry and reasonable access to all portions of the Property for the purpose of the Consultant's investigation. Borrower covenants to comply, at their sole cost and expense, with all recommendations contained in the Environmental Study reasonably required to bring the Property into compliance with all Hazardous Materials Laws and Wetlands Laws, including any recommendation for additional testing or studies to detect the source, quantity and types of Hazardous Materials or Wetlands present.

3. **Notices.** Any notice, demand, request or other communication which any party hereto may be required or may desire to give hereunder shall be in writing and shall be deemed to have been properly given (i) if hand delivered, effective upon receipt or (ii) if delivered by a nationally recognized overnight courier service, effective on the first delivery day following delivery to such courier service, or (iii) if mailed by United States registered or certified mail, postage prepaid, return receipt requested, effective two (2) postal delivery days after deposit in the United States mails; addressed in each case as follows:

If to Borrower:                   Town of Avon, Indiana  
6570 E. US Highway 36  
Avon, Indiana 46123  
Attn: Town Manager

If to Lender:                     Avon MAP, LLC  
1345C Brookville Way  
Indianapolis, Indiana 46239  
Attn: Marc Freije

or at such other address or to such other addressee as the party to be served with notice may have furnished in writing to the party seeking or desiring to serve notice as a place for the service of notice.

4. **Joint and Several Liability/Survival.** Borrower acknowledges and agrees that the obligations, representations, covenants, warranties and agreements of Borrower hereunder are joint and several. Notwithstanding anything in this Agreement or any of the other Loan Documents to the contrary, the representations and undertakings of Borrower in this Agreement shall survive the expiration or termination of the Loan and the repayment of the debt secured, regardless of the means of such expiration, termination or repayment. The repayment or discharge of the Loan and termination, release or cancellation of the Mortgage, any other security for the Loan or any of the other Loan Documents shall be deemed to effect a release of this Agreement and release of Borrower from the obligations, covenants, warranties and agreements on the part of Borrower to be performed in this Agreement. Borrower further acknowledges and agrees that this Agreement is not subject to any exculpatory provision contained in any of the Loan Documents limiting Lender's recourse to the Property or to any other security for the Loan or limiting Lender's rights to a personal and/or deficiency judgment against Borrower. Borrower further acknowledges and agrees that this Agreement and the obligations of Borrower shall not be affected by the invalidity or unenforceability of any term or provision of the Loan Documents or by the death of Borrower (or in the event that Borrower is an entity, the dissolution or termination of such entity). Lender's rights and remedies hereunder shall be in addition to all rights and remedies of Lender under the other Loan Documents, and payments by Borrower under this Agreement shall not reduce or otherwise affect Borrower's obligations

and liabilities under any other Loan Document.

5. **Successors and Assigns.** The provisions contained in this Agreement shall inure to the benefit of and be binding upon the parties hereto and their respective heirs, personal representatives, successors and assigns.

6. **Governing Law; Consent to Jurisdiction.** This Agreement is governed by the laws of the State of Indiana.

7. **Reserved.**

8. **Miscellaneous.** The liability of Borrower under this Agreement shall in no way be limited or impaired by, and Borrower hereby consents to and agrees to be bound by, any amendment to or modification of the provisions of the Loan Documents by Borrower. In addition, the liability of Borrower under this Agreement shall in no way be limited by (i) any extensions of time for performance required by any of the Loan Documents, (ii) any sale, assignment or foreclosure of any Note or the Mortgage or any sale or transfer of all or part of the Property after the foreclosure of the Mortgage or Borrower's, or its assignee's, acquisition of the Property by a deed in lieu of foreclosure of the Mortgage, (iii) the accuracy or inaccuracy of the representations and warranties made by Borrower under any of the Loan Documents, (iv) the release of Borrower or of any other person from performance or observance of any of the agreements, covenants, terms or conditions contained in any of the Loan Documents by operation of law, Lender's voluntary act, or otherwise, (v) the release or substitution in whole or in part of any security for the Loan, or (vi) Lender's failure to record the Mortgage or file any UCC financing statements (or Lender's improper recording or filing of any thereof) or to otherwise perfect, protect, secure or insure any security interest or lien given as security for the Loan.

Borrower hereby waives any right or claim of right to cause a marshalling of such party's assets or to cause Lender to proceed against any of the security for the Loan before proceeding under this Agreement against such party. Borrower hereby agrees that any payments required to be made hereunder shall become due on demand; and they expressly waive and relinquish all rights and remedies (including any rights of subrogation) accorded by applicable law to indemnitors.

No failure or delay on Lender's part to exercise any right, power or privilege under this Agreement shall operate as a waiver of any such right, power or privilege.

Any other party liable upon or in respect of this Agreement or the Loan, may be released without affecting the liability of any party not so released. Any release of a party hereto under the Loan shall not affect its or their liability hereunder unless such party is specifically released from liability under this Agreement pursuant to a written release.

No provision of this Agreement may be changed, waived, discharged or terminated orally, by telephone or by any other means except by an instrument in writing signed by the party against whom enforcement of the change, waiver, discharge or termination is sought.

In the event there shall be any inconsistency between the terms and conditions contained in this Agreement and similar terms and conditions contained in any other Loan Documents, the terms and conditions of this Agreement shall control.

This Agreement may be executed in counterparts. All executed counterparts shall constitute one agreement, and each counterpart shall be deemed an original.

9. **Waiver of Jury Trial.** Borrower hereby waives any right to a trial by jury in any action or proceeding to enforce or defend any rights under this Agreement or relating thereto or arising from the banking relationship which is the subject of this Agreement and agree that any such action or proceeding shall be tried before a court and not before a jury.

IN WITNESS WHEREOF, Borrower has caused this Agreement to be duly executed and delivered as of the Effective Date.

*(signature page follows)*

**SIGNATURE PAGE TO  
ENVIRONMENTAL INDEMNITY AGREEMENT**

BORROWER:

**TOWN OF AVON, INDIANA**

By: Exhibit Only; No Signature Required Until Closing

Printed Name: \_\_\_\_\_

Title: \_\_\_\_\_

**Exhibit A**  
**Legal Description**

**AVON REDEVELOPMENT COMMISSION**

Avon, Indiana

**HRH TIF  
Police Substation and Training Facility  
Estimated Cash Flow**

March 6, 2026





2680 East Main Street  
Suite 223  
Plainfield, IN 46168  
Phone: 317-837-4933

Email Addresses:

[greg@fsgcorp.com](mailto:greg@fsgcorp.com)

[fsg@fsgcorp.com](mailto:fsg@fsgcorp.com)

March 6, 2026

*Mr. Ryan Cannon*  
Avon Town Manager  
6570 E. U.S. Hwy. 36  
Avon, Indiana 46123

**RE: HRH TIF - POLICE SUBSTATION AND TRAINING  
FACILITY ESTIMATED CASH FLOW**

Mr. Cannon:

Pursuant to your request, we have prepared an estimate of tax increment financing ("TIF") revenue, debt service and renovation costs for the proposed Police Substation and Training Facility (the "Project"). It is our understanding that the Town intends to fund the purchase of a building and make future renovations to the building with funds from the Hendricks Regional Health tax increment financing area.

The purpose of this Report is to set forth the estimated cash flow from TIF revenue and expenses to purchase the building and fund renovations to the Project. The seller is providing \$1,053,000 in seller financing with a maturity date of 1/1/2028.

This Report is not intended to be used in a financing unless consent is given by Financial Solutions Group, Inc. (FSG Corp.).

There will usually be differences between the projected and actual results because events and circumstances frequently do not occur as expected. Those differences may be material. We have no responsibility to update the Report for events and circumstances occurring after the date of the Report.

Please give me a call if you have any questions, or need additional information

Sincerely,

*Financial Solutions Group, Inc.*

Gregory T. Guerrettaz

**AVON REDEVELOPMENT COMMISSION  
HENDRICKS REGIONAL HEALTH ECONOMIC DEVELOPMENT AREA**

**Estimated Sources & Uses of Funds**

<u>Estimated Sources of Funds</u>	<u>Police Station</u>
2026 HRH TIF Revenue	\$ 1,073,000
2027 HRH TIF Revenue	1,073,000
2028 HRH TIF Revenue	1,073,000
	<hr/>
Total Estimated Sources of Funds	<u>\$ 3,219,000</u>
<u>Estimated Uses of Funds</u>	
Earnest Money	\$ 10,000
Closing Cost	390,000
Loan Principal	1,053,000
Interest on Loan	78,975
Estimated Renovations Cost	1,047,000
	<hr/>
Total Estimated Uses of Funds	<u>\$ 2,578,975</u>
Estimated Net Revenue Available for Other Projects	<u>\$ 640,025</u>

**AVON REDEVELOPMENT COMMISSION  
HENDRICKS REGIONAL HEALTH ECONOMIC DEVELOPMENT AREA**

**Police Substation Seller Financing of 2026**

<u>Date</u>	<u>Principal</u>	<u>Interest Rate</u>	<u>Interest Amount</u>	<u>Quarterly Debt Service</u>	<u>Annual Debt Service</u>
4/1/2026					
7/1/2026	\$ -	5.00%	\$ 13,163	\$ 13,163	
10/1/2026	-	5.00%	13,163	13,163	
1/1/2027	-	5.00%	13,163	13,163	\$ 39,488
4/1/2027	-	5.00%	13,163	13,163	
7/1/2027	526,500	5.00%	13,163	539,663	
10/1/2027	-	5.00%	6,581	6,581	
1/1/2028	526,500	5.00%	6,581	533,081	1,092,488
	<u>\$ 1,053,000</u>		<u>\$ 78,975</u>	<u>\$ 1,131,975</u>	<u>\$ 1,131,975</u>

**AVON REDEVELOPMENT COMMISSION  
HENDRICKS REGIONAL HEALTH ECONOMIC DEVELOPMENT AREA**

**Police Substation Cash Flow HRH TIF Fund #4446**

Year	Estimated Revenue	Description	Estimated Expenses	Description	Estimated Balance
4/1/2026	\$ -		\$ 400,000	Payment at Closing	\$ (400,000)
6/1/2026	536,500	TIF Revenue			136,500
7/1/2026	-		13,163	Loan Payment	123,338
10/1/2026			13,163	Loan Payment	110,175
12/1/2026	536,500	TIF Revenue			646,675
1/1/2027			13,163	Loan Payment	633,513
2/1/2027			261,750	Substation Renovations	371,763
4/1/2027			13,163	Loan Payment	358,600
6/1/2027	536,500	TIF Revenue			895,100
7/1/2027			539,663	Loan Payment	355,438
8/1/2027			261,750	Substation Renovations	93,688
10/1/2027			6,581	Loan Payment	87,106
12/1/2027	536,500	TIF Revenue			623,606
1/1/2028			533,081	Loan Payment	90,525
6/1/2028	536,500	TIF Revenue			627,025
8/1/2028			261,750	Substation Renovations	365,275
12/1/2028	536,500	TIF Revenue			901,775
2/1/2029			261,750	Substation Renovations	640,025
	<u>\$ 3,219,000</u>		<u>\$ 2,578,975</u>		<u>\$ 640,025</u>

# **Avon Town Council**

## **Resolution 2026-10**

### **FORMALLY NAMING CERTAIN MUNICIPAL PARKS, TRAILS, AND RECREATIONAL FACILITIES**

**WHEREAS**, the Town of Avon has invested in the development, stewardship, and preservation of parks, recreational facilities, trails, and natural areas to enrich the quality of life for residents and visitors; and

**WHEREAS**, these public spaces provide opportunities for recreation, youth athletics, community gathering, wellness, and environmental appreciation; and

**WHEREAS**, the Town Council recognizes the importance of establishing official names for parks and recreational facilities to strengthen community identity, improve wayfinding, and celebrate the character of the Town's park system; and

**WHEREAS**, the following facilities represent a diverse and growing system of active recreation areas, natural preserves, trails, and gathering places for the community; and

**WHEREAS, Foundation Ballpark**, located at 866 S. County Road 625 W., serves as a cornerstone athletic venue supporting baseball and community events while celebrating the strong foundation of youth sports within the Town; and

**WHEREAS, APEX Ballpark**, located at 104 S. County Road 625 W., represents the pinnacle of competitive play and athletic development, providing premier ballfields for leagues, tournaments, and community recreation; and

**WHEREAS, The Summit Indoor Training**, located at 8109 Kingston Street, Suites 100-300, facility offers year-round training opportunities for athletes and teams, supporting skill development, conditioning, and recreational programming; and

**WHEREAS, Woodhaven Park**, located on County Road 900 E., provides a welcoming neighborhood park setting featuring green space, gathering areas, and opportunities for families and residents to connect with nature; and

**WHEREAS, White Lick Trail** offers residents and visitors a scenic corridor for walking, running, and cycling while connecting natural areas and neighborhoods throughout the community; and

**WHEREAS, Burnett Woods Park & Nature Preserve**, located at 925 S. County Road 800 E., protects valuable woodland habitat and provides opportunities for quiet recreation, nature exploration, and environmental education; and

**WHEREAS, World War II Memorial Park**, located at 9880 E. County Road 800 E., honors and preserves the unwavering service of the men and women and ensure that their service, sacrifice, and legacy are remembered by current and future generations; and

**WHEREAS, Blue Heron Park**, formally known as Avon Town Hall Park located at 6570 E US Highway 36, offers scenic waterfront views, walking paths, and tranquil outdoor experiences that encourage relaxation, exploration, and community enjoyment; and

**WHEREAS, The Pickle Patch**, located at 174 S. Avon Avenue, provides dedicated courts and gathering space for the rapidly growing sport of pickleball while fostering friendly competition and social recreation.

**Therefore, it is resolved**, that the Avon Town Council hereby authorizes and approves The Town Council hereby formally adopts the following names as official Town park and recreational facility designations:

1. **Foundation Ballpark**
2. **APEX Ballpark**
3. **The Summit Indoor Training**
4. **Woodhaven Park**
5. **White Lick Trail**
6. **Burnett Woods Park & Nature Preserve**
7. **World War II Memorial Park**
8. **The Pickle Patch**
9. **Blue Heron Park**

**BE IT FURTHER RESOLVED** that Town staff are directed to update all official records, signage, maps, promotional materials, and related communications to reflect these adopted names.

Resolved this 12th day of May, 2026

**AVON TOWN COUNCIL:**

---

Dawn Lowden, President

---

Jayson Puckett, Vice President

---

William Holland, Member

---

Robert Pope, Member

---

Greg Zusan, Member

**Attest:**

---

Julie Loker, Clerk-Treasurer

# Avon Town Council

## Ordinance 2026- 04

### Ordinance Prohibiting Obstruction of Mailboxes

**Whereas** , pursuant to Indiana Code §§ 36-1-3-4 and 36-1-3-6, the Town of Avon is authorized and entitled to protect the public health, safety, and welfare, and to exercise its police powers;

**Whereas** , pursuant to Indiana Code Indiana Code § 9-21-1-3, the Town of Avon also has the authority to regulate the stopping, standing, or parking of vehicles; and

**Whereas** , the stopping, standing, or parking of motor vehicles in a way that obstructs access to mailboxes or otherwise interferes with or impedes mail delivery creates both safety hazards and delays for mail carriers, and adversely affects citizens' ability to depend upon reliable mail delivery for timely services and critical deliveries; and

**Whereas** , the Town Council has a compelling interest in the protection of the public safety of its citizens and all those engaged in mail delivery, as well as the protection of the United States Postal Service's ability to safely and efficiently deliver mail to citizens of the Town of Avon; and

**Whereas** , mailbox obstruction by a motor vehicle is therefore declared to be a public nuisance where action necessary to abate the public nuisance may be required, including the towing of the motor vehicle(s) creating the nuisance; and

**Whereas** , the Town of Avon Town Council finds that it is in the best interests of the Town, its citizens, and all those engaged in mail delivery, to amend the Town of Avon Town Code to add a new section prohibiting the obstruction of mailboxes.

**Therefore, it is ordained** that Chapter 8, Article 8-6 of the Town of Avon Town Code is hereby amended to include a new section, Section 8-76, which shall read as follows:

**“ARTICLE 8-6: STANDING, STOPPING, AND PARKING REGULATIONS**

Section 8-76: Obstruction of Mailbox Prohibited

- A. Public Nuisance. The obstruction of a mailbox, defined as either a public or private container approved by the United States Postal Service for deposit of outgoing mail or receipt for incoming mail, is hereby declared to a public nuisance.
- B. Obstruction of Mailbox Defined. It is unlawful for a person to stop, stand, or park a vehicle in such as manner as to obstruct a mailbox or to interfere with the delivery of mail by the United States Postal Service.
- C. Exemptions. Vehicles following the direction of law enforcement, a traffic control device, or direction of emergency response personnel attending an emergency call are exempted from this Section. The United States Postal Service, as well as individuals stopped for the sole purpose of placing or removing mail from a mailbox, are also exempted from this Section.
- D. Penalty. Any person who violates this Section shall be guilty of an ordinance violation punishable by a fine of \$100.00 for a first offense, and a fine of \$250.00 for each subsequent offense. Any motor vehicle used to obstruct a mailbox may be towed at the direction of the Town of Avon Police Department to an area designated by the Town of Avon at the owner’s expense. The owner shall also be required to pay any and all towing and storage fees resulting from this action.

(Ordinance 2026-\_\_, passed \_\_-\_\_-26)”

**It is further ordained** that this ordinance shall become effective upon adoption.

**It is further ordained** that all other provisions of the Town Avon Town Code which are not expressly amended by this ordinance will remain in full force and effect.

**Ordained** this 12th day of March, 2026.

**Avon Town Council:**

---

Dawn Lowden, President

---

Jayson Puckett, Vice President

---

William Holland, Member

---

Robert Pope, Member

---

Greg Zusan, Member

**Attest:**

---

Julie Loker, Clerk-Treasurer

# Avon Town Council

## Ordinance 202 6-05

### Ordinance Establishing Buy Money Program and Fund

**Whereas**, the Avon Police Department wishes to establish a program for drug investigation, whereby funds will be appropriated for use in undercover drug purchases, prostitution investigations, human traffic investigations, fencing/theft investigations, and any other criminal investigation requiring the use of buy money; and

**Whereas**, the Town Council wishes to establish this program, and to establish a new fund, the Buy Money Fund, to receive and disburse funds appropriated to the program for use by the Avon Police Department; and

**Whereas**, pursuant to the State Board of Accounts Cities and Towns Bulletin and Uniform Compliance Guidelines, the Avon Police Department will maintain a minimum documentation procedure similar to either the Guidelines for Expenditure of Confidential Funds, published by the U.S. Department of Criminal Justice, or the Guidelines for Obtaining and Accounting for Confidential Funds Used in Support of Criminal Investigations, by the Indiana State Police Department; and

**Whereas**, the Avon Police Department will comply with petty cash fund procedures as authorized by Indiana Code 36-1-8-3; and

**Whereas**, the Town Council also wishes to authorize an appropriation to Buy Money Fund in the amount of ten thousand dollars (\$10,000).

**Therefore, it is ordained** as follows:

- A. The Avon Police Department Buy Money Program is hereby established;  
and
- B. Ten thousand dollars (\$10,000) is shall be appropriated to the Buy Money Fund established in Section C of this Ordinance; and
- C. The Town of Avon Internal Control policies, specifically Policy 8: Buy Money Fund, is hereby amended in part to read as described in Exhibit A.
- D. A new section, Section 2-295, shall be added to Chapter 2, Article 2-18, Division 2-18-I of the Avon Town Code, and this new section shall read as follows:

#### **“2-295 BUY MONEY FUND**

- A. Purpose .** The Town Council hereby establishes the Buy Money Fund to receive, use, and account for funds appropriated to the Buy Money fund. Funds shall be used in connection with drug investigations, prostitution investigations, human traffic investigations, fencing/theft investigations, and any other criminal investigation where buy money may be used to recover information and/or property through undercover investigative techniques conducted by the Avon Police Department, specifically for use in undercover operations.
- B. Sources of Funds.** The Buy Money Fund shall consist of money appropriated to it by the Town Council, as provided by Indiana law for other appropriations. The Police Department may also fund the Buy Money Fund through donations, court-ordered forfeitures to the Avon Police Department, court-ordered confiscations to the Avon Police Department, and other appropriate sources.

- C. Documentation.** The Chief of Police, or the Chief’s designee, shall document for all expenditures according to either the Guidelines for Expenditure of Confidential Funds, published by the U.S. Department of Criminal Justice, or the Guidelines for Obtaining and Accounting for Confidential Funds Used in Support of Criminal Investigations, by the Indiana State Police Department. The Avon Police Department will also adhere to all applicable internal controls and general orders for expenditures from the Buy Money Fund.
- D. Nonreverting Fund.** This fund shall be nonreverting and remain in effect until modified or rescinded by the Town Council.
- E. Validity.** If any provision of this ordinance is held to be invalid by a court of competent jurisdiction, all other provisions of this ordinance not otherwise invalidated will remain in full force and effect.

Ordinance 2025-\_\_\_, passed \_\_\_-\_\_\_-26”

**It is further ordained** that this ordinance is effective upon adoption.

**It is further ordained** that any other provisions of the Avon Town Code which are not specifically amended by this ordinance shall remain in full force and effect.

Ordained this \_\_\_\_\_ day of \_\_\_\_\_, 2026.

**Avon Town Council:**

\_\_\_\_\_  
Dawn Lowden, President

\_\_\_\_\_  
Jayson Puckett, Vice President

---

William Holland, Member

---

Robert Pope, Member

---

Greg Zusan, Member

**Attest:**

---

Julie Loker, Clerk-Treasurer

**Exhibit A**

**Policy 8: Buy Money Fund**

**1.01. Purpose :** The purpose of this policy is to establish internal controls for obtaining, using, and accounting for confidential funds used in support of criminal investigations.

**1.02. Policy :** Criminal investigations requiring the use of confidential monetary disbursements may be supported by the funds in the Buy Money Fund. The Buy Money Fund shall be managed by the Chief of Police. Officers requesting and utilizing funds from the Buy Money Fund shall adhere to the procedures set forth in this policy.

**1.03 General Guidelines.** The use of funds from the Buy Money Fund shall only be used in connection with criminal investigations requiring confidential money disbursements and only for the purposes approved in writing by the Chief of Police.

#### **1.04. General Procedures**

##### **1.04.01 Request Procedures**

1. Police officers requesting use of Buy Money Funds shall do so by completing an initial request form. The initial request form shall contain the requesting officer's full name, a case reference number, specify the anticipated criminal activity, describe the evidence to be received, and specify the amount of the expenditure. The expenditure amount shall not exceed \$2,500, if the expenditure is for controlled substances, and shall not exceed \$750 if the expenditure is for any other purpose, **unless authorized in writing by the Chief of Police.**
2. The request form shall be submitted to the officer's supervisor. The requesting officer's supervisor shall approve or deny the request. If denied, the request form shall be returned to the requesting officer. If the supervising officer wishes to modify the amount of funds being requested, the supervising officer shall deny the request and direct the requesting officer to submit a new request form. If approved, the supervising officer shall endorse the request by signing and dating the request form.
3. If approved, the supervising officer shall then forward the request form to the Chief of Police. The Chief of Police shall approve or deny the request. If denied, the request form shall be returned to the requesting officer. If the Chief of Police wishes to modify the amount of funds being requested, the Chief of Police shall deny the request and direct the requesting officer to submit a new request form. If approved, the Chief of Police shall endorse the request by signing and dating the request form. The Chief of Police shall also assign the request a control number, and indicate this control number on the Request for Funds form.

##### **1.04.02 Draw Procedures**

1. After the initial request form is approved and endorsed by a supervising officer and the Chief of Police, the Chief of Police shall submit a draw request form to the Clerk-Treasurer. The draw request form shall contain the following information:
  - a. The name of the requesting officer;
  - b. The amount of the expenditure; and

- c. The control number.
2. The Clerk-Treasurer shall issue a check or money order made payable to the requesting officer, and deliver the check to the Chief of Police. The Chief of Police shall deliver the check to the requesting officer. The employee shall be the only person authorized to endorse the check.
3. The Clerk-Treasurer shall also issue a receipt to the Chief of Police for the disbursement to the requesting officer.

#### **1.04.03 Procedures Relating to Use and Return of Funds**

1. Funds advanced to a requesting officer shall only be held outstanding for up to 48 hours. If it becomes apparent at any point within the 48-hour period that the expenditure will not materialize, the funds must be returned to the Chief of Police. The Chief of Police will then return the funds to the Clerk-Treasurer as soon as possible. An extension of the 48-hour limit may be granted by the requesting officer's supervising officer and the Chief of Police. Such extensions shall be indicated on the initial request form, and if approved, endorsed with both the supervising officer and the Chief of Police's signature and date of approval.
2. Unused checks shall be returned to the Chief of Police, unendorsed, with a memorandum explaining the reason for the return of the unused check. The Chief of Police shall deliver the unused check to the Clerk-Treasurer.
3. Following the related investigative police action, an officer who receives funds from the Buy Money Fund shall return the funds to the requesting officer's supervisor with in 24 hours, or at the beginning of the officer's next shift, with a supplemental report which contains the following information:
  - a. The officer's name;
  - b. The control number;
  - c. Date the supplemental report was prepared;
  - d. Date of each expenditure;
  - e. Amount of each expenditure;
  - f. Description of each expenditure;
  - g. Amount of funds held in evidence;
  - h. Date of return of funds; and
  - i. Case reference number.
4. The supervising officer shall review the supplemental report for accuracy and completeness, and sign and date the supplemental report. The supervising officer shall then present the funds and the supplemental report to the Chief of Police, who shall also sign and date the supplemental report upon approval.

5. The Chief of Police shall prepare a return form, which contains the following information:
  - a. The check number;
  - b. The control number;
  - c. The amount of the check;
  - d. The name of the payee;
  - e. The amount of the expenditure, in the event funds are not returned in full, either due to loss of funds during an official police investigation;
  - f. The amount of funds held in evidence in the event funds are held in evidence subject to return upon the conclusion of criminal investigation and prosecution; and
  - g. The amount of the returned funds.
6. The Chief of Police shall present to the Clerk-Treasurer the form and the returned funds, if any.
7. In the event funds are held in evidence, upon conclusion of criminal investigation and prosecution, the Chief of Police shall submit a supplemental return form and the funds to the Clerk-Treasurer.
8. The Clerk-Treasurer shall deposit returned funds in the Buy Money Fund.
9. The Clerk-Treasurer shall adhere to all petty cash fund procedures as authorized by Ind. Code 36-1-8-3.

#### **1.04.04 Accounting and Documentation**

1. The Chief of Police shall keep a written ledger and recording the following information for each disbursement:
  - a. The date the check is written;
  - b. The check number;
  - c. The control number;
  - d. The amount of the check; and
  - e. The name of the payee (i.e. the requesting officer).
2. The Chief of Police shall maintain the written ledger and copies of all request forms, receipts, memorandums of explanation submitted for unused checks, supplemental reports, return forms, and supplemental return forms.
3. The Chief of Police, or the Chief of Police's designee, shall prepare a monthly reconciliation of the funds disbursed and refunded to the Buy Money Fund, and submit the reconciliation report to the Clerk-Treasurer.
4. The Clerk-Treasurer shall prepare an annual report to the Town Council reporting the reconciliation of the Buy Money Fund.

#### **1.05 General Controls**

1. Money drawn from the Buy Money Fund shall not be spent for any purpose other than that for which it was requested unless granted by prior written approval from the requesting officer's supervisor and the Chief of Police.
2. Employees who violate the provisions of this policy are subject to discipline, including but not limited to termination.

# Avon Town Council

## Ordinance 2026-06

### APPROVING THE REQUEST OF CHURCHYARD, LLC. AND THE REZONING OF A CERTAIN PARCEL OF LAND FROM THE GENERAL INDUSTRIAL DISTRICT (I-2), TO THE GENERAL COMMERCIAL DISTRICT (C-2)

WHEREAS, Churchyard, Inc. (“Petitioner”) filed a proposal to rezone from the General Industrial District (I-2) to the General Commercial District (C-2), a parcel of land located at 8403 East US Highway 36, which has been annexed into the Town of Avon, containing approximately 2.08 acres (a legal description for the parcel is attached as Exhibit A); and

WHEREAS, in its petition for rezone, the Petitioner stated the purpose of the rezoning is to legally establish existing commercial businesses on the property; and

WHEREAS, the Town of Avon Plan Commission published notice of a public hearing on February 12, 2026, and conducted a public hearing on the proposal on February 23, 2026, in its case ZA 25-03; and

WHEREAS, the Plan Commission considered the Petitioner’s request, comments by the public, the case report, and comments by the Planning staff, and forwarded a favorable recommendation by a vote of five (5) in favor of and zero (0) for the rezoning on February 23, 2026; and

WHEREAS, the Plan Commission properly certified its recommendation to the Avon Town Council on March 2, 2026; and

WHEREAS, the Avon Town Council, having considered the certification of the Plan Commission, presentations of the Planning staff and the Petitioner and comments from the public, and having paid reasonable regard to this evidence and

1. the Town of Avon Comprehensive Plan;
2. the current conditions and the character of current structures and uses in each zoning district;
3. the most desirable use for which the land in each district is adapted;
4. the conservation of property values throughout the Town of Avon; and
5. responsible development and growth

now finds that the requested proposal to rezone the subject land should be granted because (1) the approval will not be injurious to the public health, safety, morals and general welfare of the community, (2) the use and character of land and structures in the area adjacent to the subject site and in the area generally will not be affected in a substantially adverse manner; (3) the proposed rezone will not decrease the value of property in the area of the subject property; (4) the proposed rezone is generally consistent with the goals of the Comprehensive Plan; and (5) the approval of the requested rezone is consistent with the interests of responsible development and growth in that the development will not unduly burden local schools, local or state roads and highways, or unduly burden utility providers; and

IT IS, THEREFORE, ORDAINED that the subject real estate is hereby rezoned from the General Industrial District (I-2) to the General Commercial District (C-2), and the Planning Director is directed to change the Zoning Maps,

which are incorporated into the Zoning Ordinance, in order to reflect this rezone and to maintain a record of the conditions contained in this approval.

IT IS FURTHER ORDAINED that this ordinance is effective upon adoption.

Adopted: March 12, 2026.

Avon Town Council:

\_\_\_\_\_  
Dawn Lowden, President

\_\_\_\_\_  
Jayson Puckett, Vice-President

\_\_\_\_\_  
William Holland

\_\_\_\_\_  
Robert, Pope

\_\_\_\_\_  
Greg Zusan

Attest: \_\_\_\_\_  
Julie Loker, Clerk-Treasurer

I AFFIRM, UNDER THE PENALTIES FOR PERJURY, THAT I HAVE TAKEN REASONABLE CARE TO REDACT EACH SOCIAL SECURITY NUMBER IN THIS DOCUMENT, UNLESS REQUIRED BY LAW.

\_\_\_\_\_  
Linda Ahlbrand

This instrument prepared by Linda Ahlbrand, Planning Director of the Town of Avon, 6570 East U. S. Highway 36, Avon, Indiana, 46123.

Exhibit A

Legal Description for proposed rezoning petition ZA 25-03 –

8403 East U.S. Highway 36:

Lot Numbered Two (2) in The Gatherings Minor Plat 06-02, an addition to the Town of Avon, Hendricks County, Indiana, as per plat thereof recorded April 4, 2007, in Plat Cabinet 6, Slide 192, Page 1, in the Office of the Recorder of Hendricks County, Indiana.



**Town of Avon  
Advisory Plan Commission  
Certification**

The Town of Avon Advisory Plan Commission met on Monday, February 23, 2026, to consider proposed zoning map amendment **ZA 25-03: The Gatherings, Lot 2**. Notice of Public Hearing was mailed by the petitioner on **January 16, 2026**, and legal notice was published in a newspaper of general circulation in Hendricks County, Indiana on **February 12, 2026**.

**ZA 25-03 The Gatherings Lot 2, requests a favorable recommendation of a petition to rezone 2.08 acres, from the I-2 General Industrial District to the C-2 General Commercial District, to legally establish existing retail uses. The property is located 8403 East U.S. Highway 36**

**Petitioner: Churchyard LLC, c/o David Gilman**

A motion was approved to forward to the Avon Town Council, a favorable recommendation of ZA 25-03 by a vote of 5-0.

As the Planning Director for the Town of Avon Advisory Plan Commission, I do hereby certify that the above is a true and accurate record of the proceedings of the meeting of the Town of Avon Advisory Plan Commission held on February 23, 2026.

\_\_\_\_\_  
Linda Ahlbrand, Planning Director, Town of Avon

March 2, 2026

\_\_\_\_\_  
Date